

HA -2

HEATING, VENTILATION AND AIR CONDITIONING

GENERAL**SPECIFICATION** E6EB1946**AIR CONDITIONER**

Item		Specification
Compressor	Type	VS16
	Oil type & Capacity	PAG(FD46XG) / 150±10
	Pulley type	6PK-TYPE
	Displacement	180cc/rev
Condenser	Heat rejection	15,000 - 5% kcal/hr
APT (A/C pressure transducer)	The method to measure the pressure	Voltage = 0.00878835 * Pressure + 0.5
Expansion valve	Type	Block
Refrigerant	Type	R-134a
	Capacity (OZ. (g))	22.9 ± 0.88 (650 ± 25)

BLOWER UNIT

Item		Specification
Fresh and recirculation	Operating method	Actuator
Blower	Type	Sirocco
	Speed step	Auto + 8 speed (Automatic)
	Speed control	Power mosfet
Air filter	Type	Particle filter

A/C COMPRESSOR CONTROLS (MANUAL)

AIR CONDITIONING COMPRESSOR

COMPONENTS EC5FAB75

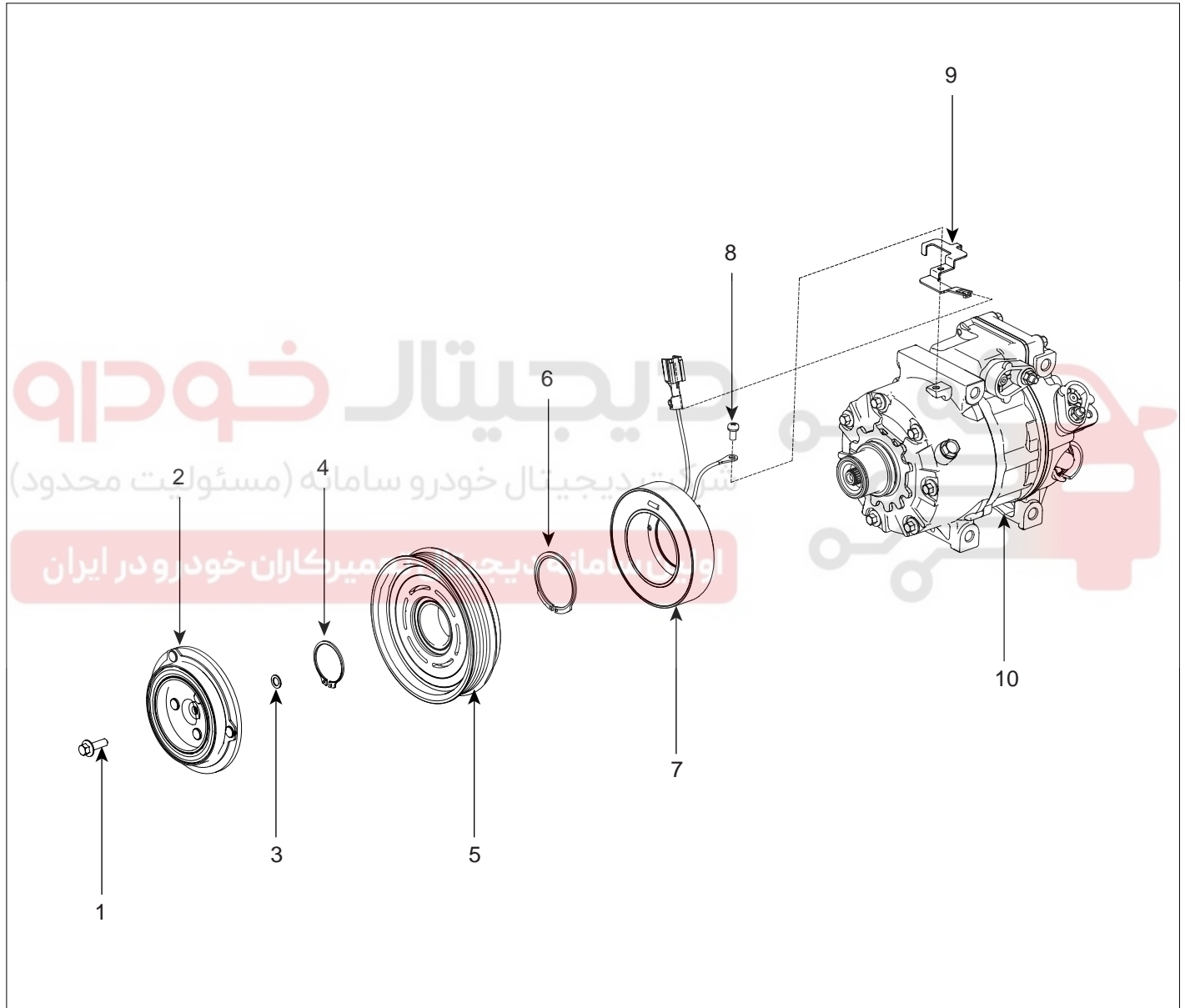

- | | |
|-------------------------------|-------------------------|
| 1. Bolt | 8. Screw |
| 2. Disc & hub assembly | 9. Connector bracket |
| 3. Shim (Gap washer) | 10. Compressor assembly |
| 4. Retainer ring (Pulley) | 11. Manifold |
| 5. Pulley | 12. Bolt wrench |
| 6. Retainer ring (Field coil) | 13. Gasket |
| 7. Field coil | |

SGHHA6300L

HA -4

HEATING, VENTILATION AND AIR CONDITIONING

REMOVAL

E66EF6C0

1. If the compressor is marginally operable, run the engine at idle speed, and let the air conditioning work for a few minutes, then shut the engine off.
2. Disconnect the negative cable from the battery.
3. Recover the refrigerant with a recovery/charging station (Refer to HA-8).
4. Loosen the drive belt (Refer to HA-14).
5. Remove the bolts, then disconnect the suction line (A) and discharge line (B) from the compressor. Plug (C) or cap the lines immediately after disconnecting them to avoid moisture and dust contamination.

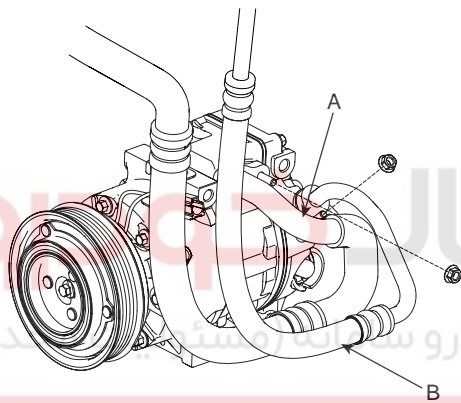

KQRE105C

6. Disconnect the compressor clutch connector (A), and then remove 4 mounting bolts and the

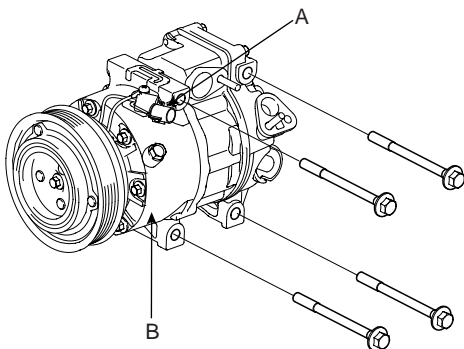

KQRE105D

INSTALLATION

E6A1AFDC

1. Make sure of the length of compressor mounting bolts, and then tighten it A B C D order.

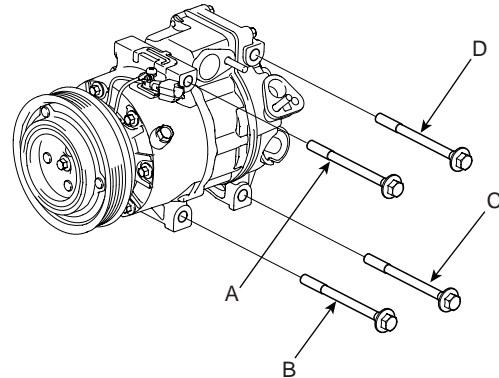

KQRE105E

2. Install in the reverse order of removal, and note these items.
 - If you're installing a new compressor, drain all the refrigerant oil from the removed compressor, and measure its volume, Subtract the volume of drained oil from 120cc(4.20 oz.) the result is the amount of oil you should drain from the new compressor (through the suction fitting).
 - Replace the O-rings with new ones at each fitting, and apply a thin coat of refrigerant oil before installing them. Be sure to use the right O-rings for R-134a to avoid leakage.
 - To avoid contamination, do not return the oil to the container once dispensed, and never mix it with other refrigerant oils.
 - Immediately after using the oil, replace the cap on the container and seal it to avoid moisture absorption.
 - Do not spill the refrigerant oil on the vehicle; it may damage the paint; if the refrigerant oil contacts the paint, wash it off immediately.
 - Adjust the drive belt (Refer to HA-14)
 - Charge the system and test its performance. (Refer to HA-9)

A/C COMPRESSOR CONTROLS (MANUAL)

HA -5

INSPECTION

E7ACCC57

1. Check the plated parts of the disc & hub assembly (A) for color changes, peeling or other damage. If there is damage, replace the clutch set.
2. Check the pulley (B) bearing play and drag by rotating the pulley by hand. Replace the clutch set with a new one if it is noisy or has excessive play/drag.

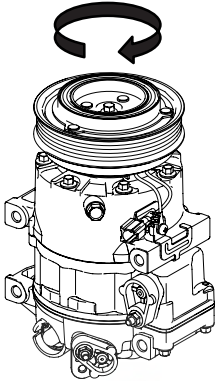

4. Check operation of the magnetic clutch. Connect the compressor side terminals to the battery (+) terminal and the ground battery (-) terminal to the compressor body. Check the magnetic clutch operating noise to determine the condition.

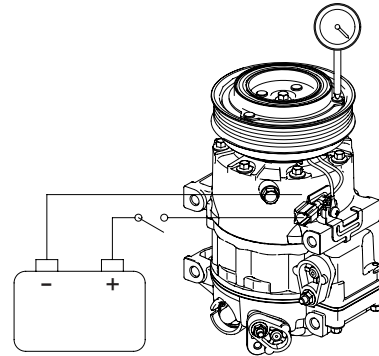

KQRE105H

3. Measure the clearance between the pulley (B) and the disc & hub assembly (A) all the way around. If the clearance is not within specified limits, remove the disc & hub assembly and add or remove shim (gap washer) as needed to increase or decrease clearance. Clearance: $0.45 \pm 0.1\text{mm}$ ($0.018 \pm 0.004\text{ in.}$)

NOTE

The shims (gap washers) are available in seven thicknesses: 0.7mm, 0.8mm, 0.9mm, 1.0mm, 1.1mm, 1.2mm and 1.3mm.

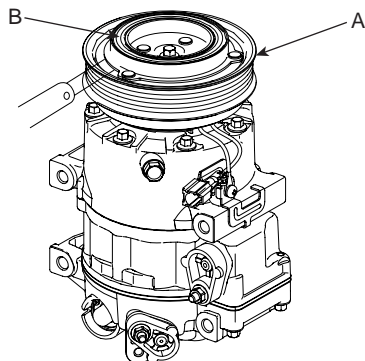

KQRE105G

HA -6

HEATING, VENTILATION AND AIR CONDITIONING

DISASSEMBLY E51A7FEB

1. Remove the center bolt (A) while holding the disc & hub assembly with a commercially available disc & hub assembly bolt remover; Special tool number 09977-29000.

TORQUE: 10~15N.m (1.02~1.53kgf.m, 7.37~11lbf.ft)

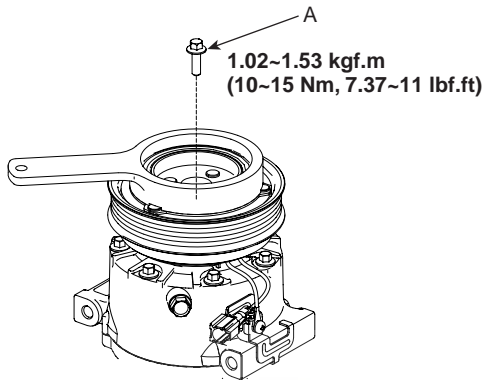

KQRE105I

2. Remove the disc & hub assembly (A) and shim (gap washer) (B), taking care not to lose the shims. If the clutch needs adjustment, increase or decrease the number and thickness of shims as necessary, then re-install the disc & hub assembly, and recheck its clearance (Refer to HA-19).

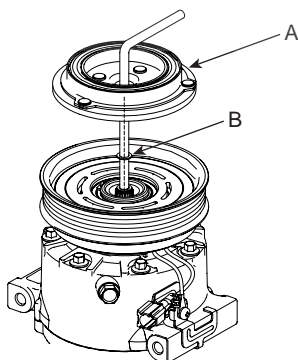

KQRE105J

3. If you removal the field coil, remove retainer ring (A) with retainer ring pliers.

NOTE

- Be careful not to damage the pulley (B) and compressor during removal/installation.
- Once retainer ring (A) is removed, replace it with a new one.

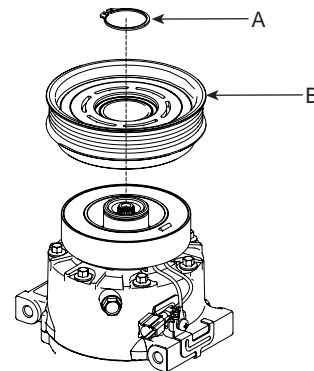

KQRE105K

4. Remove the screw (A) from the field coil ground terminal. Remove the retainer ring (B) and then remove the field coil (C) from the shaft with a puller. Be careful not to damage the coil and compressor.

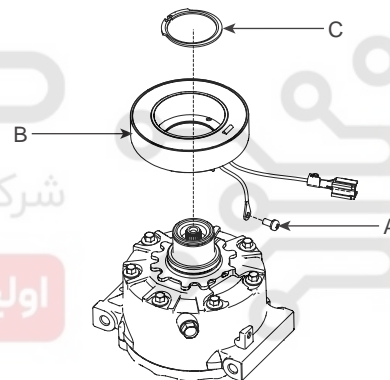

KQRE105L

5. Reassemble the compressor clutch in the reverse order of disassembly, and note these items :
 - Clean the pulley and compressor sliding surfaces with non-petroleum solvent.
 - Install new retainer rings, and make sure they are fully seated in the groove.
 - Make sure that the pulley turns smoothly after its reassembled.

A/C COMPRESSOR CONTROLS (MANUAL)

HA -7

A/C PRESSURE TRANSDUCER

COMPONENTS LOCATION E3C11EAF

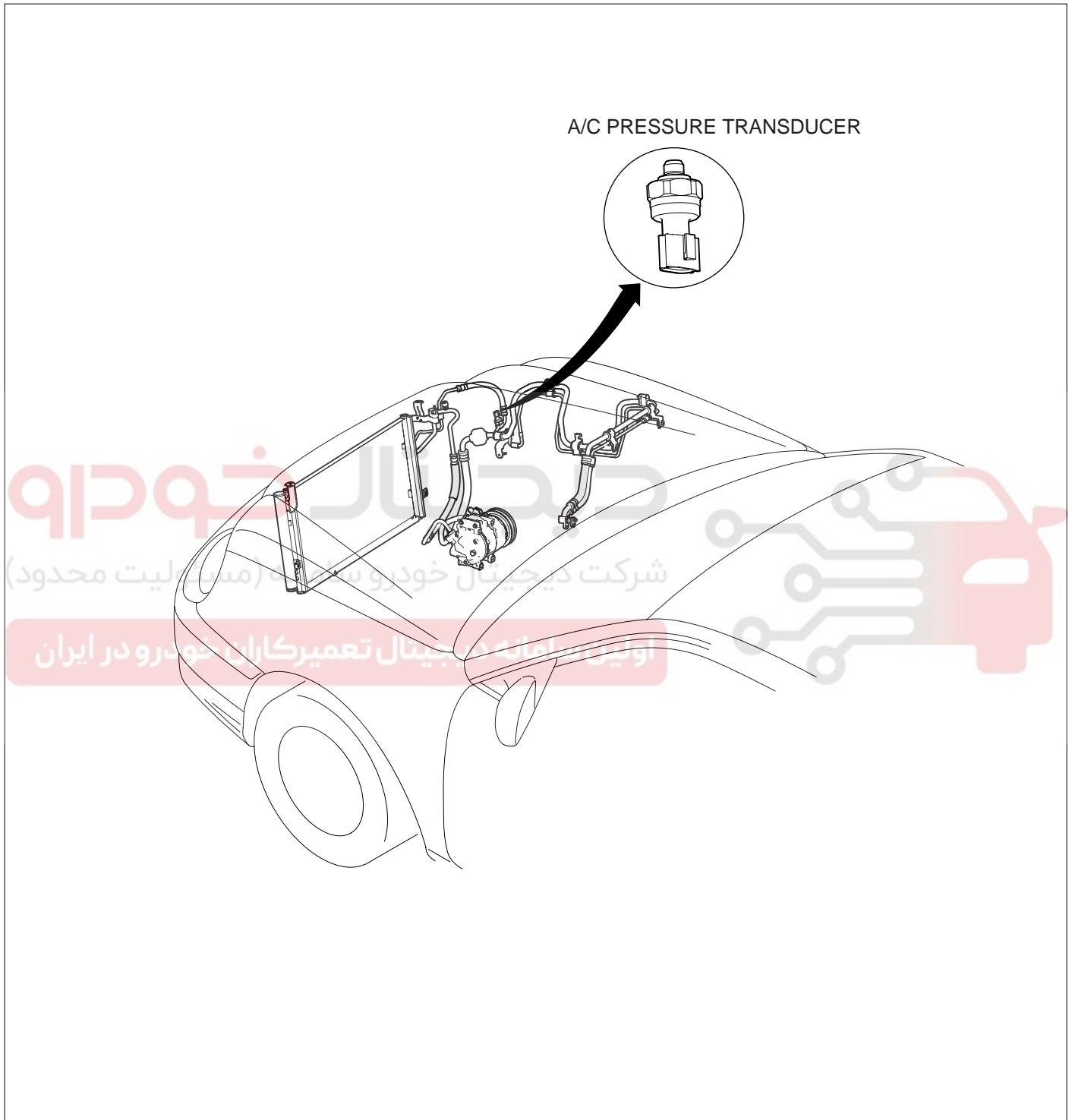

SGHHA6130L

HA -8

HEATING, VENTILATION AND AIR CONDITIONING

DESCRIPTION EAD7CDBF

A/C pressure transducer convert the pressure value of high pressure line into voltage value after measure it. By converted voltage value, engine ECU controls cooling fan by operating it high speed or low speed. Engine ECU stop the operation of compressor when the temperature of refrigerant line is so high or so low irregularly to optimize air conditioning system.

INSPECTION EEBA7F55

1. Measure the pressure of high pressure line by measuring voltage output between NO.1 and NO.2 terminals

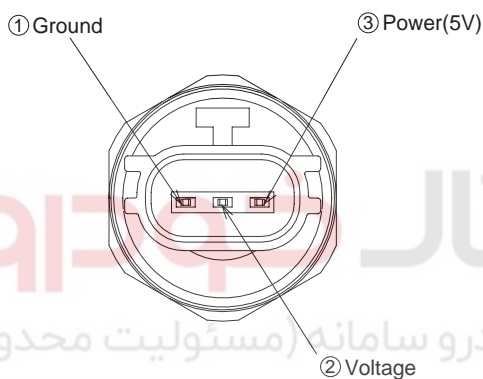

2. Inspect the voltage value whether it is sufficient to be regular value or not.

$$\text{Voltage} = 0.00878835 \times \text{Pressure} + 0.5 \text{ [PSIA]}$$

3. If the measured voltage value is not specification, replace the A/C pressure transducer.

REPLACEMENT EAF0347E

1. Disconnect the negative (-) battery terminal.
2. Recover the refrigerant with a recovery/charging station.
3. Remove the front bumper(Refer to BD group-front bumper).
4. Disconnect A/C pressure transducer connector (3P) (A).

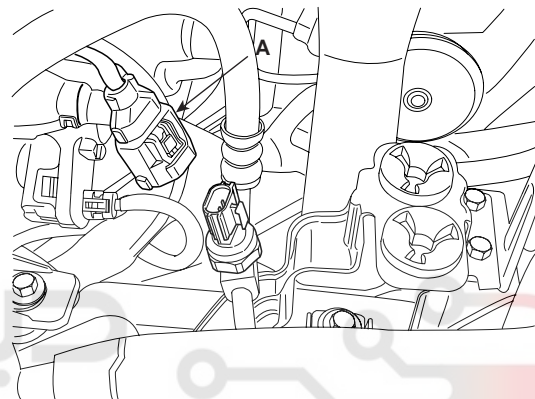

SGHHA6001D

5. Remove the A/C pressure transducer.

⚠ CAUTION

Take care that liquid & suction pipe are not bent.

6. Installation is the reverse order of removal.

TORQUE: 10~12N.m (1.0~1.2kgf.m, 7.4~8.8lbf.ft)

A/C COMPRESSOR CONTROLS (FULL AUTO)

HA -9

A/C COMPRESSOR
CONTROLS (FULL AUTO)

IN CAR SENSOR

DESCRIPTION EE09E724

1. In-car air temperature sensor is located at the center facia lower panel.
2. The sensor contains a thermistor which measures the temperature of the inside. The signal decided by the resistance value which changes in accordance with perceived inside temperature, is delivered to heater control unit and according to this signal the control unit regulates incar temperature to intended value.

INSPECTION E79DC3C7

1. Ignition "ON"
2. Blow air with changing temperature to the in car sensor air inlet. Measure sensor resistance between 1 and 3 terminals.

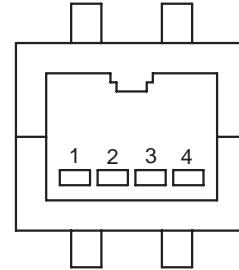

1. Sensor ground
2. Motor
3. In-car sensor signal
4. Motor (+)

SGHHA6301L

SPECIFICATION

Temperature [()]	Resistance between terminals 1and 3 (kΩ)
-30(-22)	528.174 ± 4.35 %
-15(5)	218.237 ± 3.43%
0(32)	97.830 ± 2.61%
15(59)	47.117 ± 1.45%
25(77)	30.000 ± 1.20%
35(95)	19.601 ± 1.44%
60(140)	7.478 ± 2.82%
80(176)	3.225 ±3.69%

 **NOTE**

In car sensor is negative type thermistor that resistance will rise with lower temperature, and reduce with higher temperature.

HA -10

HEATING, VENTILATION AND AIR CONDITIONING

REPLACEMENT EAB35F50

1. Disconnect the negative (-) battery terminal.
2. Remove the center console (Refer to BD group-console)
3. Remove the cluster garnish (A)

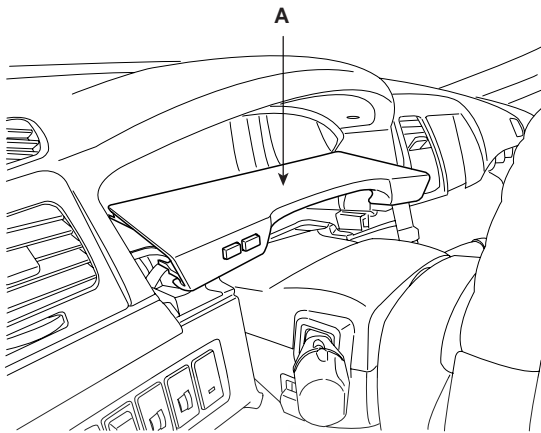

SGHHA6002D

4. After loosening the screw, then remove the crash pad center garnish (B).

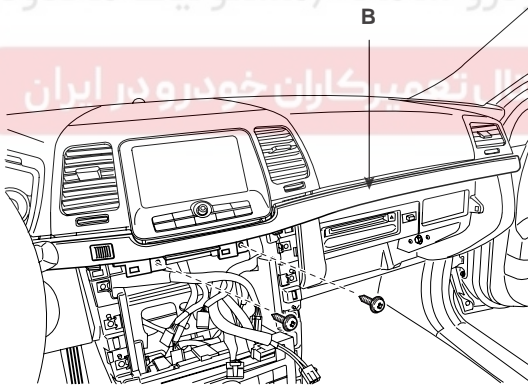

SGHHA6003L

5. Remove the In-car sensor (A).

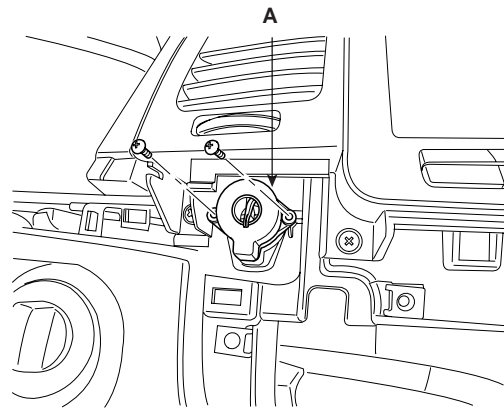

SGHHA6004L

6. Installation is the reverse of removal.

BLOWER CONTROLS

HA -11

BLOWER CONTROLS

POWER MOSFET

INSPECTION E5662FBA

1. Ignition "ON"
2. Manually operate the control switch and measure the voltage of blower motor.
3. Select the control switch to raise voltage until high speed.

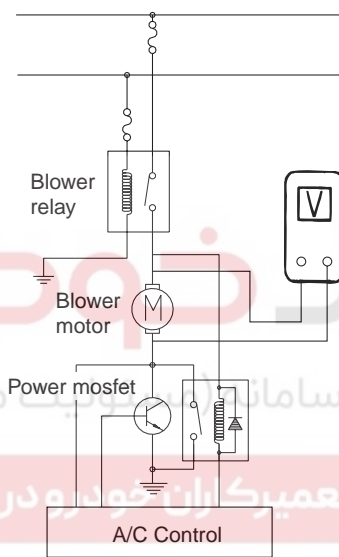

SUNHA6800L

SPECIFICATION

Fan	Motor Voltage	
	Manual	AUTO
First speed	3.8	AUTO Lo(4.5)
Second speed	4.9	4.6~5.5
Third speed	6.1	5.6~6.7
Fourth speed	7.3	6.8~7.7
Fifth speed	8.3	7.8~8.9
Sixth speed	9.5	9.0~10.1
Seventh speed	10.6	10.2~AUTO HI(10.6)
eighth speed	Battery(+)	Battery(+)

4. If the measured voltage is not specification, substitute with a known-good power mosfet and check for proper operation.

5. If the problem is corrected, replace the power mosfet.

REPLACEMENT E96DFB72

1. Disconnect the negative (-) battery terminal.
2. Remove the cresh pad.
3. Disconnect the power mosfet connector (A).

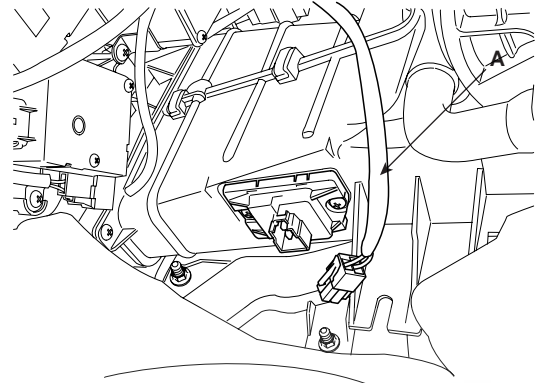

SGHHA6005D

4. Remove the power mosfet (B) after loosening the mounting screws.

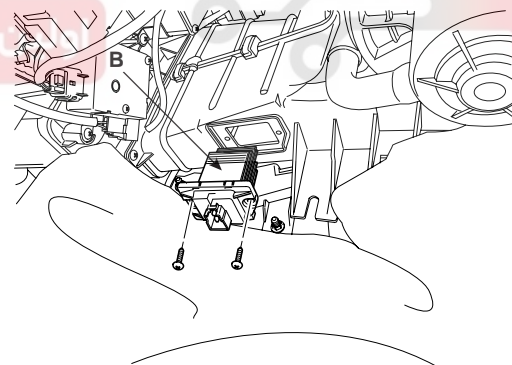

SGHHA6006D

5. Installation is the reverse order of removal.

HA -12

HEATING, VENTILATION AND AIR CONDITIONING

BLOWER AND A/C CONTROLS (AUTOMATIC)

CONTROL PANEL

EEE5686E

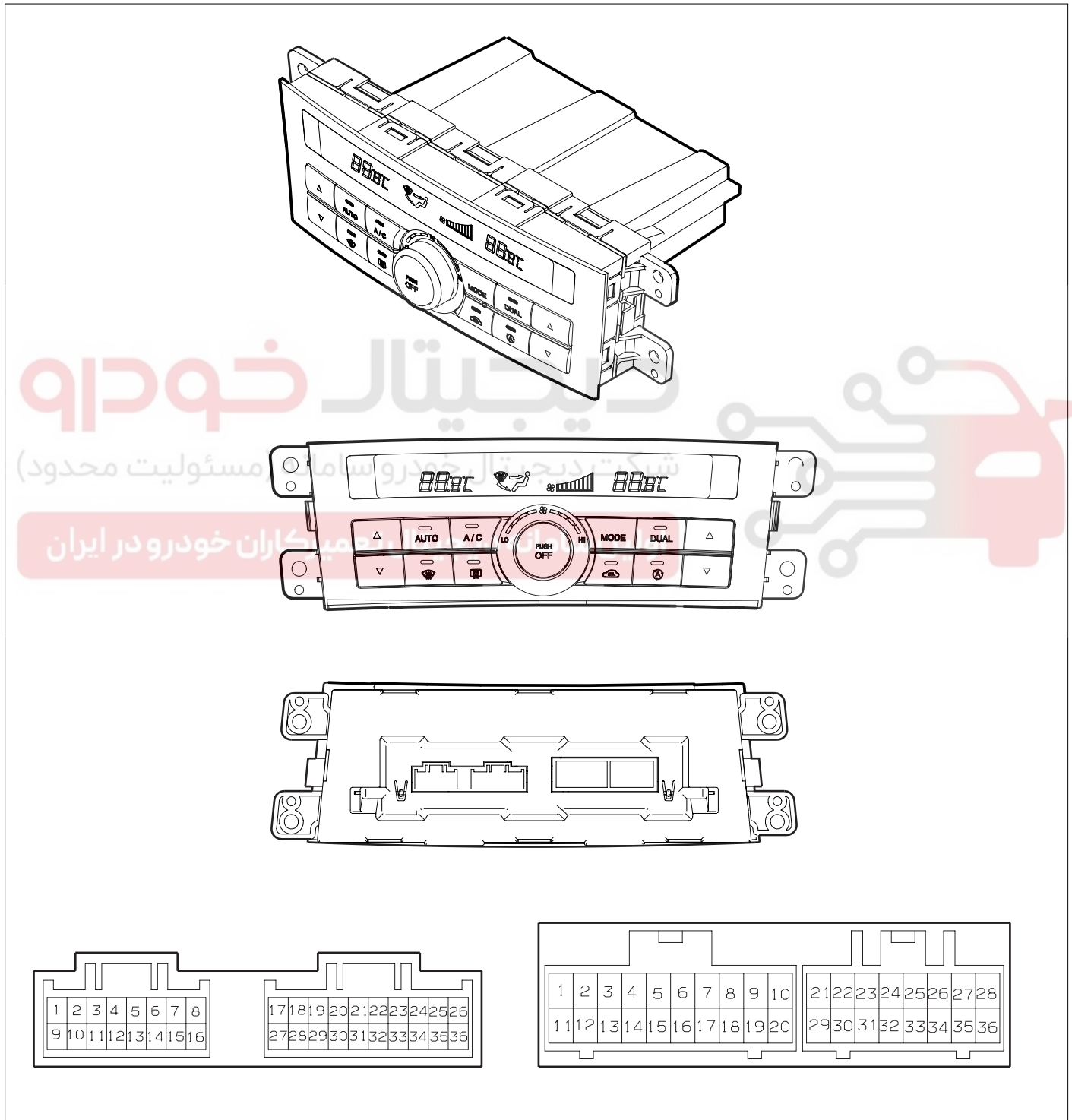

SGHHA6011D

BLOWER AND A/C CONTROLS (AUTOMATIC)**HA -13****CONNECTOR PIN FUNCTION**

CONNECTOR	PIN	FUNCTION	CONNECTOR	PIN	FUNCTION
CONNECTOR (A)	1	DR PHOTO SENSOR(-)	CONNECTOR (B)	1	DR.MODE ACTUATOR F/B
	2	EVAPORATOR SENSOR		2	DR.TEMP ACTUATOR F/B
	3	AMB SENSOR		3	REAR VENT MOTOR(+)
	4	INCAR SENSOR		4	INTAKE ACTUATOR MOTOR(+)
	5	INCAR MOTOR(-)		5	PA.MODE MOTOR(+)
	6	REF(+5V)		6	DR.MODE MOTOR(+)
	7	SENSOR GND		7	PA.TEMP MOTOR(+)
	8	-		8	DR.TEMP MOTOR(+)
	9	PA PHOTO SENSOR(-)		9	-
	10	PHOTO SENSOR (+)		10	RHEOSTAT (+)
	11	TRIP COMPUTOR		11	PA.MODE ACTUATOR F/B
	12	WATER TEMP SENSOR		12	PA.TEMP ACTUATOR F/B
	13	HUMIDIT SENSOR		13	REAR VENT MOTOR(-)
	14	SENSOR GND		14	INTAKE ACTUATOR MOTOR(-)
	15	SENSOR GND		15	PA.MODE MOTOR(-)
	16	SPEED SENSOR		16	DR.MODE MOTOR(-)
	17	POWER MOSFET(DRAIN)		17	PA.TEMP ACTUATOR MOTOR(-)
	18	BATTERY		18	DR.TEMP ACTUATOR MOTOR(-)
	19	IGN2-1		19	-
	20	IGN2-2		20	RHEOSTAT (-)
	21	-		21	A/C INDICATOR
	22	RR DEFOGGER SWITCH		22	A/C SWITCH
	23	AQS		23	TEMP CONTROL SWITCH(UP)
	24	REAR VENT SWITCH		24	-
	25	-		25	-
	26	GND		26	REF(+5V)
	27	-		27	REAR VENT/TEMP SWITCH F/B
	28	POWER MOSFET(GATE)		28	REAR VENT/TEMP MOTOR(-)
	29	IGN2		29	VENT INDICATOR
	30	IGN2		30	VENT INDICATOR
	31	A/C OUTPUT		31	TEMP CONTROL SWITCH(DOWN)

HA -14

HEATING, VENTILATION AND AIR CONDITIONING

CONNECTOR PIN FUNCTION

CONNECTOR	PIN	FUNCTION	CONNECTOR	PIN	FUNCTION
CONNECTOR (A)	32	RR DEFOGGER INDICATOR	CONNECTOR (B)	32	-
	33	A/C SELECTOR		33	-
	34	REAR VENT INDICATOR		34	SENSOR GND
	35	K-LINE		35	REAR VENT/TEMP F/B
	36	GND		36	REAR VENT/TEMP MOTOR(+)

دیجیتال خودرو

شرکت دیجیتال خودرو سامانه (مسئولیت محدود)

اولین سامانه دیجیتال تعمیرکاران خودرو در ایران



BLOWER AND A/C CONTROLS (AUTOMATIC)

HA -15

INSPECTION EB0B8CE9

1. DTC CODES

FAULT CODE

CODE	FAIL DESCRIPTION
B 1202	WATER TEMP SENSOR OPEN
B 1203	WATER TEMP SENSOR SHORT
B 1233	INCAR SENSOR SHORT
B 1234	INCAR SENSOR OPEN
B 1237	AMBIETSENSOR SHORT
B 1238	AMBIET SENSOR OPEN
B 1241	EVAPORATOR SENSOR SHORT
B 1242	EVAPORATOR SENSOR SOPEN
B 1245	DR TEMP F/B OPEN
B 1246	DR TEMP F/B SHORT
B 1249	DR. MODE F/B OPEN
B 1250	DR. MODE F/B SHORT
B 1200	HUMIDITY SENSOR OPEN
B 1201	HUMIDITY SENSOR SHORT
B 1204	PA. TEMP F/B OPEN
B 1205	PA. TEMP F/B SHORT
B 1206	PA. MODE F/B OPEN
B 1207	PA. MODE F/B SHORT
B 2406	DR. TEMP MOTOR
B 2409	DR. MODE MOTOR
B 2415	PA. TEMP MOTOR
B 2416	PA. MODE MOTOR
B 2417	REAR VENT/TEMP F/B OPEN
B 2418	REAR VENT/TEMP F/B SHORT

HA -16

HEATING, VENTILATION AND AIR CONDITIONING

2. FAIL SAFE

NO.	ITEM	FAIL FUNCTION
1	IN-CAR	Control with the value of 25°C(77°F)
2	Ambient temperature sensor	Control with the value of 20°C(67°F)
3	Evaporator temperature sensor	Control with the value of -2°C(28.4°F)
4	Water temperature sensor	Control with the value of -2°C (28.4°F)
5	Temperature control actuator	If temperature setting 17°C-24.5°C, fix at maximum cooling position. If temperature setting 25°C-32°C, fix at maximum heating position.
6	Mode control actuator	Fix vent position, while selecting vent mode. Fix defrost position, while selecting all except vent mode.
7	AQS sensor	AQS operation OFF. (Intake position : The position before selecting AQS switch.)
8	Humidity sensor	Doesn' t control.

دیجیتال خودرو

شرکت دیجیتال خودرو سامانه (مسئولیت محدود)

اولین سامانه دیجیتال تعمیرکاران خودرو در ایران



BLOWER AND A/C CONTROLS (AUTOMATIC)**HA -17****REPLACEMENT** EFEF56CD

1. Disconnect the negative (-) battery terminal.
2. Remove the center console. (Refer to BD group-center console)
3. Remove the crash pad center lower garnish (A).

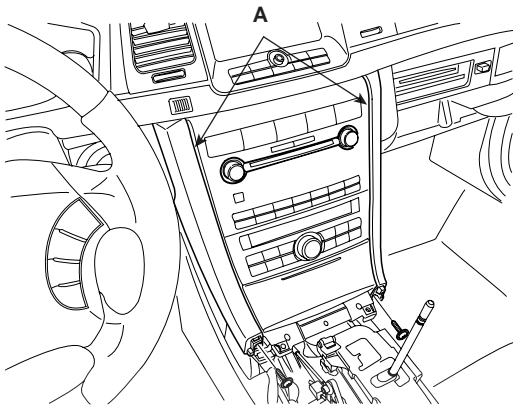

SGHHA6007D

4. Remove the center facia tray (B) after loosening 4 screws.

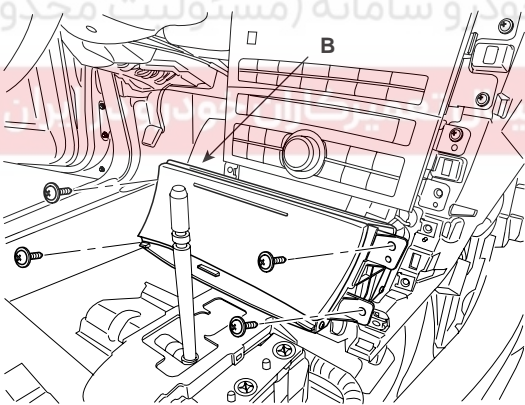

SGHHA6008D

5. Remove the Heater & A/C controller (A) after loosening 4 screws.

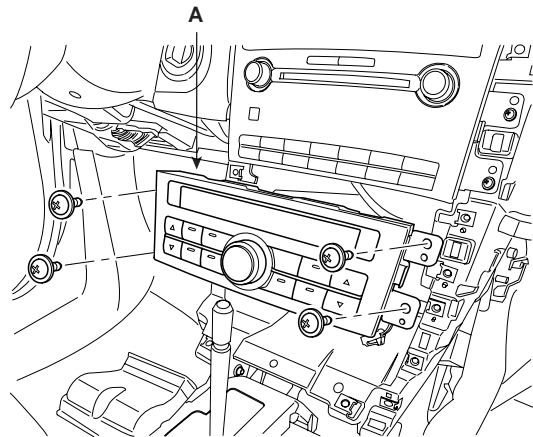

SGHHA6009D

6. Disconnect the connector (B), and then remove the A/C controller.

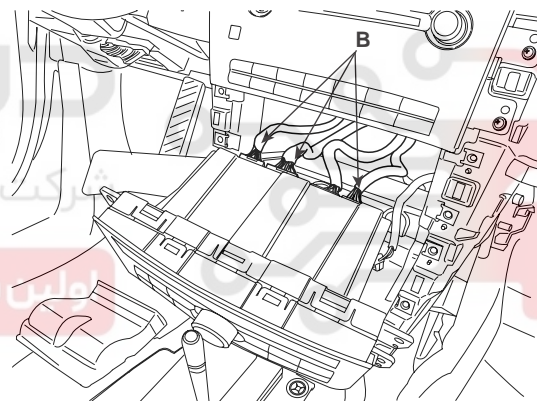

SGHHA6010D

7. Installation is the reverse order of removal.

HA -18

HEATING, VENTILATION AND AIR CONDITIONING

DTC B1200 HUMIDITY SENSOR OPEN (HIGH)

COMPONENT LOCATION EEAED598

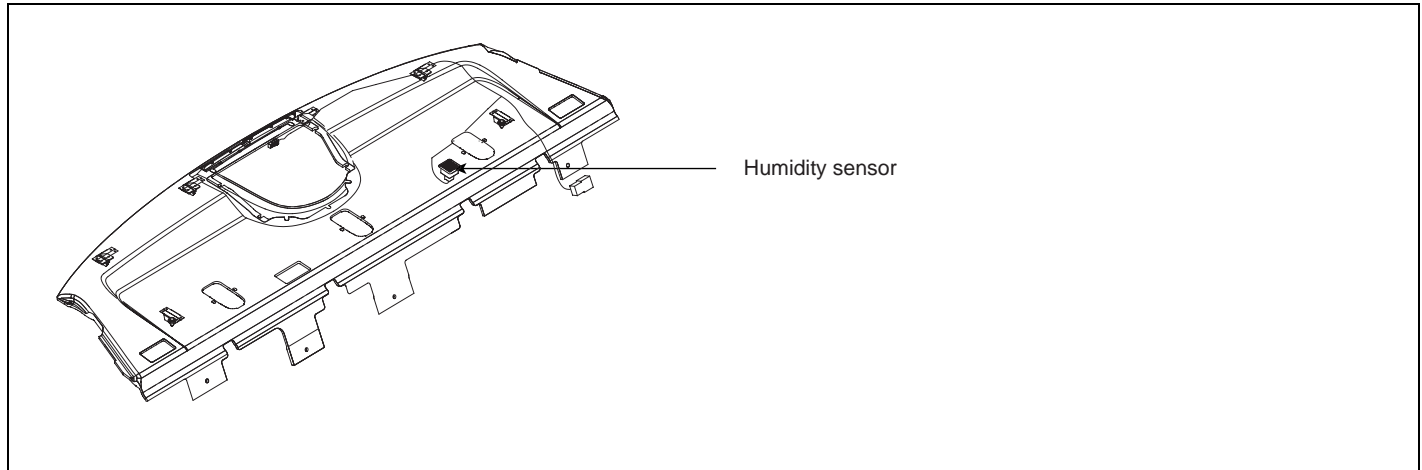

SGHHA6263L

GENERAL DESCRIPTION E813CFB8

Humidity sensor located at crush pad, detects in-car humidity for in-car humidity control. If ambient air temperature or in-car humidity is outside certain range, it will turn on A/C to control in-car humidity for preventing in-car fogging. Air conditioner operation depends on ambient temperature and humidity.

DTC DESCRIPTION E26F8FC5

The A/C controller sets DTC B1200 if there is an open circuit in humidity sensor signal harness or the measured voltage value of sensor is more than threshold value (about 0.94V)

DTC DETECTING CONDITION E609B0DF

Item	Detecting Condition	Possible cause
DTC Strategy	• Voltage check	<ul style="list-style-type: none"> • Open Circuit in signal harness • Faulty Humidity Sensor • Faulty A/C control unit
Threshold value	• > 7,100 Hz	
Detecting time	• 0.3 sec	
FAIL SAFE	• -	

SPECIFICATION EF7B8179

Humidity (%)	Voltage (V)	Humidity (%)	Voltage (V)
30	3.13	65	1.29
35	3.07	70	1.12
40	2.94	75	1.05
45	2.67	80	1.01
50	2.35	85	0.99
55	2.01	90	0.94
60	1.54		

BLOWER AND A/C CONTROLS (AUTOMATIC)

HA -19

MONITOR SCANTOOL DATA EA55BAF5

1. Connect scantool to data link connector(DLC).
2. Engine "ON"
3. Monitor the "Humidity Sensor" Parameter on the Scantool while drying the humidity sensor with a hair drier or heat gun adjusted to a low heat setting.

1.2 CURRENT DATA	
HUMIDITY SENSOR	10 %
HEATER WATER TEMP.SNSR	12.0 °C
IN-CAR TEMP.SENSOR	11.0 °C
AMBIENT AIR TEMP.SNS	11.5 °C
EVAPORATIVE SENSOR	12.5 °C
DRIVER PHOTO SENSOR	0.00 V
AIR MIX POPENATIO. (DR.)	91.75 %
DIRECTION POTENIO. DR.	89.79 %

1.1 DIAGNOSTIC TROUBLE CODES	
B1200 HUMIDITY SENSOR - OPEN(HIGH)	
NUMBER OF DTC : 1 ITEMS	

Fig 1

Fig 1 : The current data in abnormal state.

Fig 2

Fig 2 : DTC B1200.

4. Are the DTC B1200 present and is parameter of "Humidity Sensor" fixed?
Parameter of "Humidity Sensor" will be fixed at 10%, if there is any fault in Humidity Sensor.

YES

Go to "Inspection" procedure.

NO

Fault is intermittent caused by poor contact in the sensor's and/or A/C controller's connector or was repaired and A/C controller memory was not cleared. Thoroughly check connectors for looseness, poor connection, bending, corrosion, contamination, deterioration, or damage. Repair or replace as necessary and then go to "Verification of Vehicle Repair" procedure.

TERMINAL AND CONNECTOR INSPECTION E5F388B6

1. Many malfunctions in the electrical system are caused by poor harness and terminals.
Faults can also be caused by interference from other electrical systems, and mechanical or chemical damage.
2. Thoroughly check connectors for looseness, poor connection, bending, corrosion, contamination, deterioration, or damage.
3. Has a problem been found?

YES

Repair as necessary and go to "Verification of Vehicle Repair" procedure.

HA -20

HEATING, VENTILATION AND AIR CONDITIONING

NO

Go to "Signal circuit inspection" procedure.

SIGNAL CIRCUIT INSPECTION EE9EA63F

1. Check for open in harness.
 - 1) Ignition "OFF"
 - 2) Disconnect Humidity Sensor.
 - 3) Measure resistance between terminal "2" of Humidity Sensor and terminal "13" of A/C Control Unit.

Specification : Approx. 0

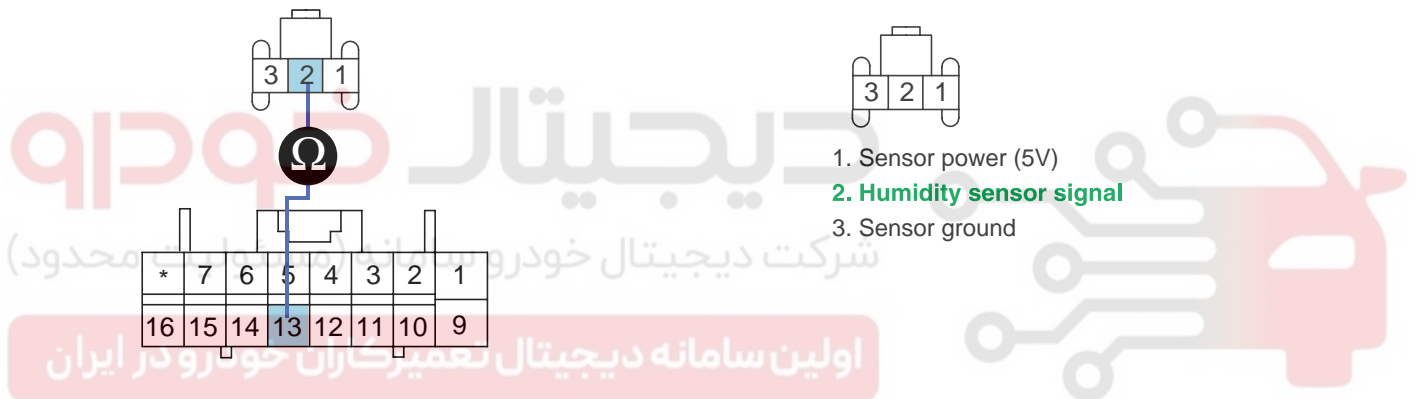

SGHHA6200L

- 4) Is the measured resistance within specifications?

YES

Go to "Ground circuit Inspection " procedure.

NO

Check for open in harness. Repair as necessary and go to "Verification of Vehicle Repair" procedure.

GROUND CIRCUIT INSPECTION E607AF32

1. Check for open in ground harness.
 - 1) Ignition "OFF"
 - 2) Disconnect Humidity Sensor.
 - 3) Measure resistance between terminal "3" of Humidity Sensor and terminal "13" of A/C Control Unit.

Specification :Approx. 0

BLOWER AND A/C CONTROLS (AUTOMATIC)

HA -21

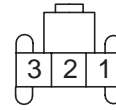
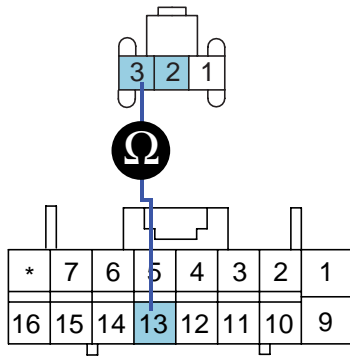

1. Sensor power (5V)
2. Humidity sensor signal
3. Sensor ground

SGHHA6600L

4) Is the measured resistance within specifications?

YES

Go to "Component Inspection " procedure.

NO

Check for open in ground harness. Repair as necessary and go to "Verification of Vehicle Repair" procedure.

COMPONENT INSPECTION

E3A920B6

1. Check Humidity Sensor.

- 1) Engine "ON"
- 2) Connect Humidity Sensor.
- 3) Measure Frequency between terminal 2 of Humidity sensor and chassis ground.

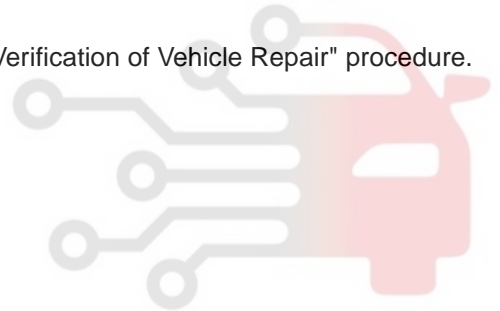

Specification : Refer the specifications in fig 5.

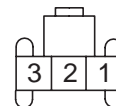
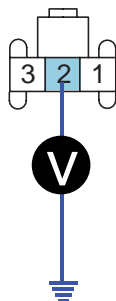

1. Sensor power (5V)
2. Humidity sensor signal
3. Sensor ground

SGHHA6202L

HA -22

HEATING, VENTILATION AND AIR CONDITIONING

Humidity (%)	Voltage (V)	Humidity (%)	Voltage (V)
30	3.13	65	1.29
35	3.07	70	1.12
40	2.94	75	1.05
45	2.67	80	1.01
50	2.35	85	0.99
55	2.01	90	0.94
60	1.54		

4) Is the measured voltage within specifications in fig 5?

YES

Go to "Check A/C Control Unit" procedure.

NO

Substitute with a known-good Humidity sensor and check for proper operation.

If the problem is corrected, replace Humidity sensor and then go to "Verification of Vehicle Repair" procedure.

2. Check A/C Control Unit

1) Engine "ON"

2) Disconnect Humidity Sensor.

3) Measure voltage value between terminal "6" of A/C control unit and chassis ground.

Specification : 5V

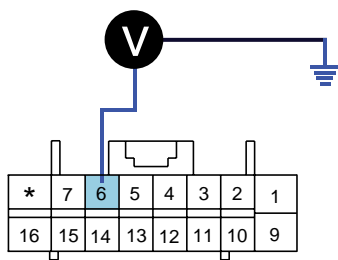

6. Humidity sensor signal

LQKG510G

4) Is the measured voltage within specification?

YES

Check connectors for looseness, poor connection, bending, corrosion, contamination, deterioration, or damage. Repair or replace as necessary and then go to "Verification of Vehicle Repair" procedure.

NO

Substitute with a known-good A/C Control Unit and check for proper operation.

If the problem is corrected, replace A/C Control Unit and then go to "Verification of Vehicle Repair" procedure.

BLOWER AND A/C CONTROLS (AUTOMATIC)

HA -23

VERIFICATION OF VEHICLE REPAIR E0FE9B19

After a repair, it is essential to verify that the fault has been corrected.

1. Connect scantool and select "Diagnostic Trouble Codes(DTCs)" mode and then clear DTC.
2. Operate the vehicle and monitor the DTC on the scantool.
3. Are any DTCs present?

YES

Go to the applicable troubleshooting procedure.

NO

System is performing to specification at this time.

دیجیتال خودرو

شرکت دیجیتال خودرو سامانه (مسئولیت محدود)

اولین سامانه دیجیتال تعمیرکاران خودرو در ایران



HA -24

HEATING, VENTILATION AND AIR CONDITIONING

DTC B1201 HUMIDITY SENSOR SHORT (LOW)

COMPONENT LOCATION E8DBC6DD

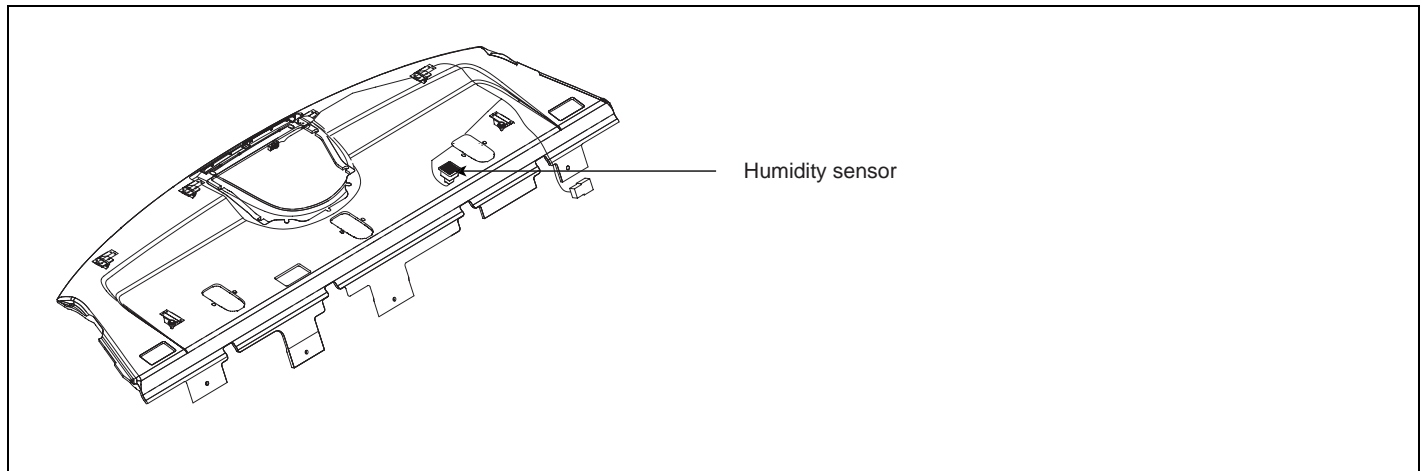

SGHHA6263L

GENERAL DESCRIPTION E40CCE08

Refer to DTC P1200.

DTC DESCRIPTION ED9AB2BE

The A/C controller sets DTC B1201 if there is a short circuit in humidity sensor signal harness or the measured voltage value of sensor is less than threshold value(about 3.13V)

DTC DETECTING CONDITION ED9D02C4

Item	Detecting Condition	Possible cause
DTC Strategy	<ul style="list-style-type: none"> Voltage check 	<ul style="list-style-type: none"> Open Circuit in power harness Short Circuit in signal harness Faulty Humidity Sensor Faulty A/C control unit
Threshold value	<ul style="list-style-type: none"> < 3.13V 	
Detecting time	<ul style="list-style-type: none"> 0.3 sec 	
FAIL SAFE	<ul style="list-style-type: none"> - 	

SPECIFICATION E39EABFF

Refer to DTC P1200.

MONITOR SCANTOOL DATA E1282110

1. Connect scantool to data link connector(DLC).
2. Engine "ON"
3. Monitor the "Humidity Sensor" Parameter on the Scantool while drying the humidity sensor with a hair drier or heat gun adjusted to a low heat setting.

BLOWER AND A/C CONTROLS (AUTOMATIC)

HA -25

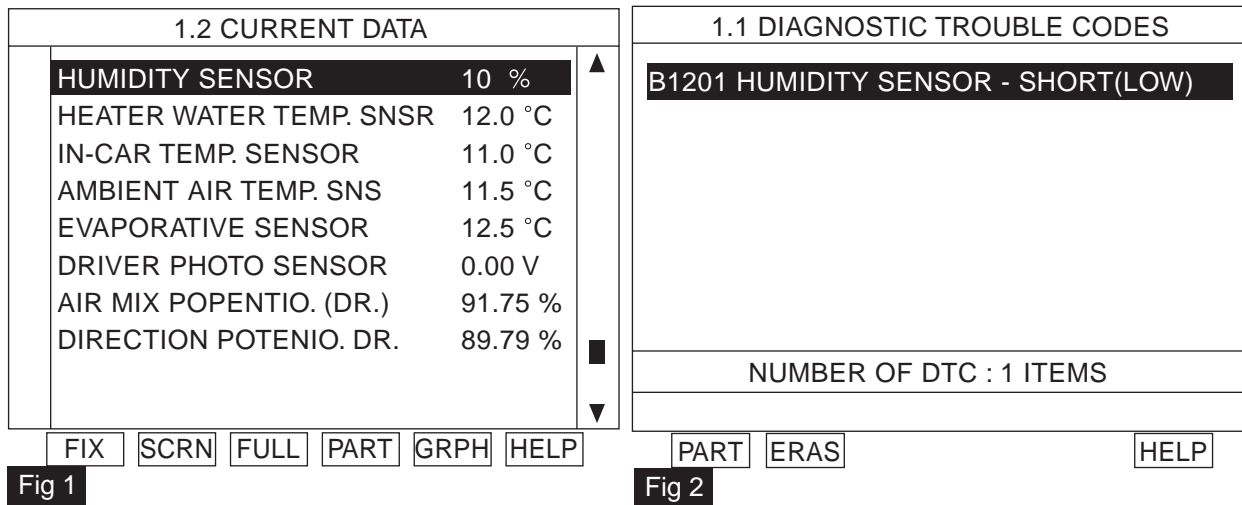

Fig 1 : The current data in abnormal state.

Fig 2 : DTC B1201.

LQIE511A

4. Are the DTC B1201 present and is parameter of "Humidity Sensor" fixed?

Parameter of "Humidity Sensor" will be fixed at 10%, if there is any fault in Humidity Sensor.

YES

Go to "Inspection" procedure.

NO

Fault is intermittent caused by poor contact in the sensor's and/or A/C controller's connector or was repaired and A/C controller memory was not cleared. Thoroughly check connectors for looseness, poor connection, bending, corrosion, contamination, deterioration, or damage. Repair or replace as necessary and then go to "Verification of Vehicle Repair" procedure.

TERMINAL AND CONNECTOR INSPECTION E46CEF9E

Refer to DTC P1200.

SIGNAL CIRCUIT INSPECTION ECC3D1A0

1. Check for short to ground in harness.
 - 1) Ignition "OFF"
 - 2) Disconnect Humidity Sensor.
 - 3) Measure resistance between terminal "1" and "2".

Specification : Approx.

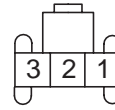
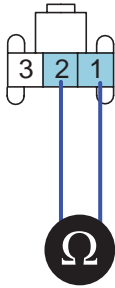

1. Sensor power (5V)
2. In-car sensor signal
3. Sensor ground

SGHHA6203L

4) Is the measured resistance within specifications?

YES

Go to "Power circuit Inspection " procedure.

NO

Check for short to ground in harness. Repair as necessary and go to "Verification of Vehicle Repair" procedure.

POWER SUPPLY CIRCUIT INSPECTION ED180193

1. Check for open in power harness.

- 1) Ignition "ON" اولین سامانه دیجیتال تعمیرکاران خود را
- 2) Disconnect Humidity Sensor.
- 3) Measure voltage value between terminal "1" of Humidity Sensor and chassis ground.

Specification : 5V

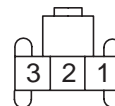
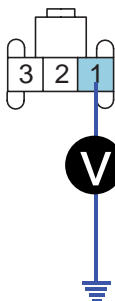

1. Sensor power (5V)
2. In-car sensor signal
3. Sensor ground

SGHHA6201L

BLOWER AND A/C CONTROLS (AUTOMATIC)

HA -27

4) Is the measured voltage within specifications?

YES

Go to "Component Inspection " procedure.

NO

Check for open in power harness. Repair as necessary and go to "Verification of Vehicle Repair" procedure.

COMPONENT INSPECTION E21ABF1E

Refer to DTC B1200.

VERIFICATION OF VEHICLE REPAIR ECEB8038

Refer to DTC B1200.

دیجیتال خودرو

شرکت دیجیتال خودرو سامانه (مسئولیت محدود)

اولین سامانه دیجیتال تعمیرکاران خودرو در ایران



HA -28

HEATING, VENTILATION AND AIR CONDITIONING

DTC B1202 WATER TEMPERATURE SENSOR OPEN (HIGH)

COMPONENT LOCATION EAD67CBE

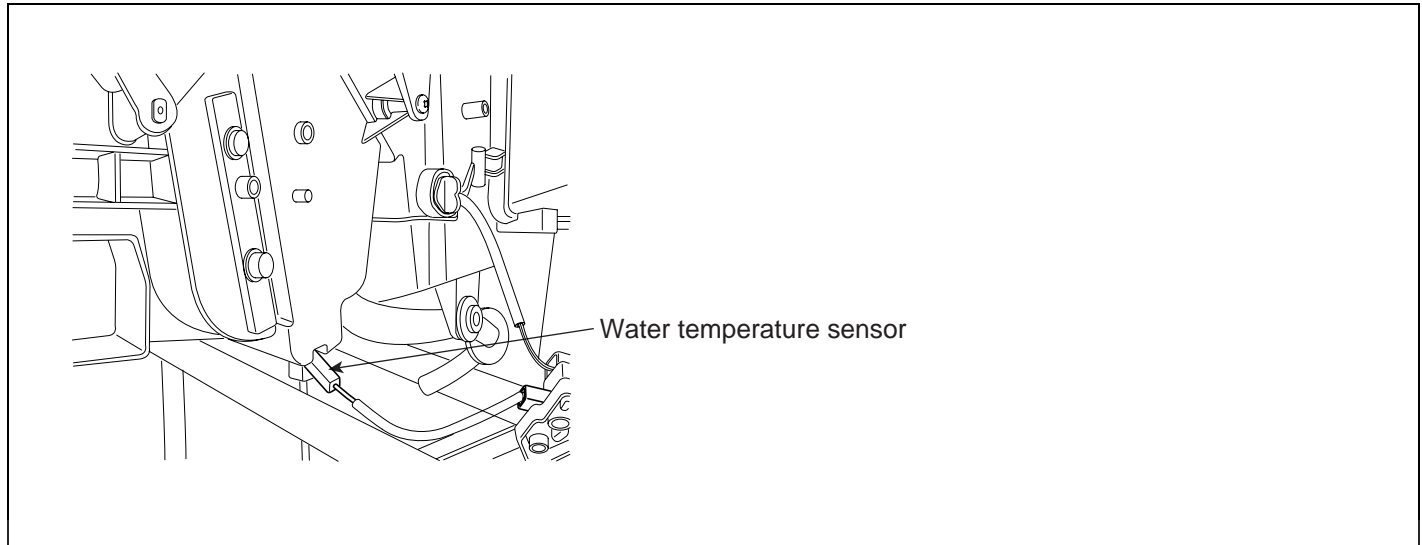

SGHHA6601L

GENERAL DESCRIPTION E79C5561

A water temp. sensor located at heater unit, detects coolant temperature. Its signal is used for cold engine lockout control. When the driver operates the heater before the engine is warmed up, the signal from sensor causes the heater control unit to reduce blower motor speed until coolant temperature reaches the threshold value.

DTC DESCRIPTION EFAC8202

The A/C controller sets DTC B1202 if there is an open circuit in water temp. sensor signal harness or the measured resistance value of the sensor is more than the threshold value(about 55.27k)

DTC DETECTING CONDITION EDDA37B8

Item	Detecting Condition	Possible cause
DTC Strategy	• Resistance check	<ul style="list-style-type: none"> • Open Circuit in harness • Faulty water temp. Sensor • Faulty A/C control unit
Threshold value	• > 55.27 k	
Detecting time	• 0.3 sec	
FAIL SAFE	• Control with the value of -2°C(28.4°F)	

SPECIFICATION EEDFF0BB

Temperature[°C(°F)]	Resistance(k)	Temperature[°C(°F)]	Resistance(k)
-10 (14)	55.845	40 (104)	5.311
0 (32)	32.909	60 (140)	2.48
20 (68)	12.51	80 (176)	1.246

BLOWER AND A/C CONTROLS (AUTOMATIC)

HA -29

MONITOR SCANTOOL DATA E23A4490

1. Connect scantool to data link connector(DLC).
2. Engine "ON"
3. Monitor the "WATER TEMP. SENSOR" Parameter on the Scantool.

1.2 CURRENT DATA		1.1 DIAGNOSTIC TROUBLE CODES	
HEATER WATER TEMP. SNSR	-2 °C	B1202 WATER TEMP. SENS - OPEN(HIGH)	
IN-CAR TEMP. SENSOR	12.0 °C		
AMBIENT AIR TEMP. SNS	11.5 °C		
EVAPORATIVE SENSOR	12.5 °C		
DRIVER PHOTO SENSOR	0.00 V		
AIR MIX POPENATIO. (DR.)	91.75 %		
DIRECTION POTENIO. DR.	54.89 %		
PASSENGER PHOTO SENSOR	255		
		NUMBER OF DTC : 1 ITEMS	

Fig 1

Fig 1 : The current data in abnormal state.

Fig 2

Fig 2 : DTC B1202.

4. Are the DTC B1202 present and is parameter of "WATER TEMP. SENSOR" fixed?
Parameter of "WATER TEMP. SENSOR" will be fixed at -2 (28.4°F), if there is any fault in WATER TEMP. SENSOR.

YES

Go to "Inspection" procedure.

NO

Fault is intermittent caused by poor contact in the sensor's and/or A/C controller's connector or was repaired and A/C controller memory was not cleared. Thoroughly check connectors for looseness, poor connection, bending, corrosion, contamination, deterioration, or damage. Repair or replace as necessary and then go to "Verification of Vehicle Repair" procedure.

TERMINAL AND CONNECTOR INSPECTION EC92E599

1. Many malfunctions in the electrical system are caused by poor harness and terminals.
Faults can also be caused by interference from other electrical systems, and mechanical or chemical damage.
2. Thoroughly check connectors for looseness, poor connection, bending, corrosion, contamination, deterioration, or damage.
3. Has a problem been found?

YES

Repair as necessary and go to "Verification of Vehicle Repair" procedure.

HA -30

HEATING, VENTILATION AND AIR CONDITIONING

NO

Go to "Signal circuit inspection" procedure.

SIGNAL CIRCUIT INSPECTION EE5CF56F

1. Check for open in harness.
 - 1) Ignition "OFF"
 - 2) Disconnect water temp. sensor.
 - 3) Measure resistance between terminal "1" of water temp. sensor and terminal "12" of A/C Control Unit.

Specification : Approx. 0

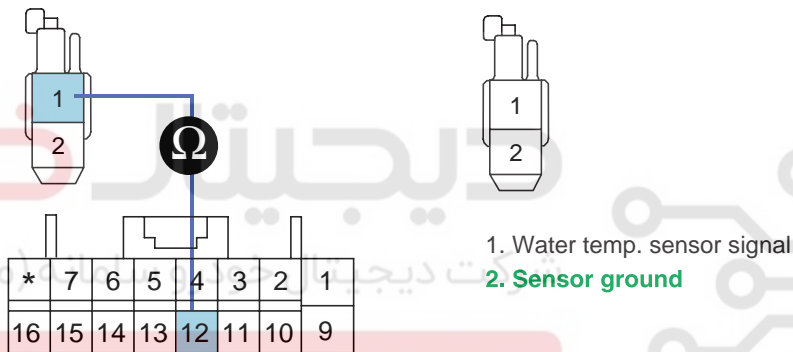

SGHHA6204L

- 4) Is the measured resistance within specifications?

YES

Go to "Ground circuit Inspection " procedure.

NO

Check for open in harness. Repair as necessary and go to "Verification of Vehicle Repair" procedure.

GROUND CIRCUIT INSPECTION E20A6934

1. Check for open in ground harness.
 - 1) Ignition "OFF"
 - 2) Disconnect water temp. sensor.
 - 3) Measure resistance between terminal "2" of water temp. sensor and chassis ground.

Specification : Approx. 0

BLOWER AND A/C CONTROLS (AUTOMATIC)

HA -31



- 1. Water temp. sensor signal
- 2. Sensor ground

SGHHA6205L

4) Is the measured resistance within specifications?

YES

Go to "Component Inspection " procedure.

NO

Check for open in ground harness. Repair as necessary and go to "Verification of Vehicle Repair" procedure.

COMPONENT INSPECTION

E8B1ACAD

1. Check water temp. sensor.

- 1) Ignition "OFF"
- 2) Disconnect water temp. sensor.
- 3) Measure resistance between terminal "1" and "2" of water temp. sensor.

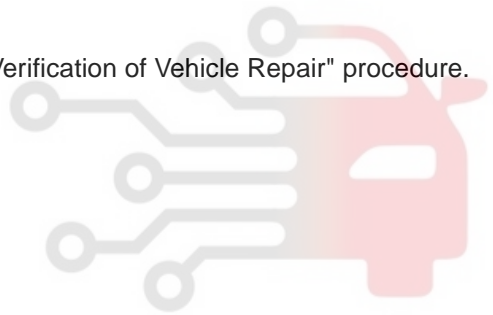

Specification : Refer the specifications in fig 3.

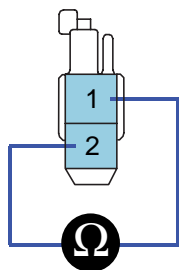

- 1. Water temp. sensor signal
- 2. Sensor ground

SGHHA6602L

Temperature[°C(°F)]	Resistance(k)	Temperature[°C(°F)]	Resistance(k)
-10 (14)	55.845	40 (104)	5.311
0 (32)	32.909	60 (140)	2.48
20 (68)	12.51	80 (176)	1.246

HA -32

HEATING, VENTILATION AND AIR CONDITIONING

- 4) Is the measured resistance within specifications in fig 3)? (tolerance limits $\pm 3\%$)

YES

Go to "Check A/C Control Unit" procedure.

NO

Substitute with a known-good water temp. sensor and check for proper operation.

If the problem is corrected, replace water temp. sensor and then go to "Verification of Vehicle Repair" procedure.

2. Check A/C Control Unit

- 1) Engine "ON"
- 2) Disconnect water temp. sensor.
- 3) Measure Voltage between terminal "12" of A/C Control Unit and chassis ground.

Specification : Approx. 5V

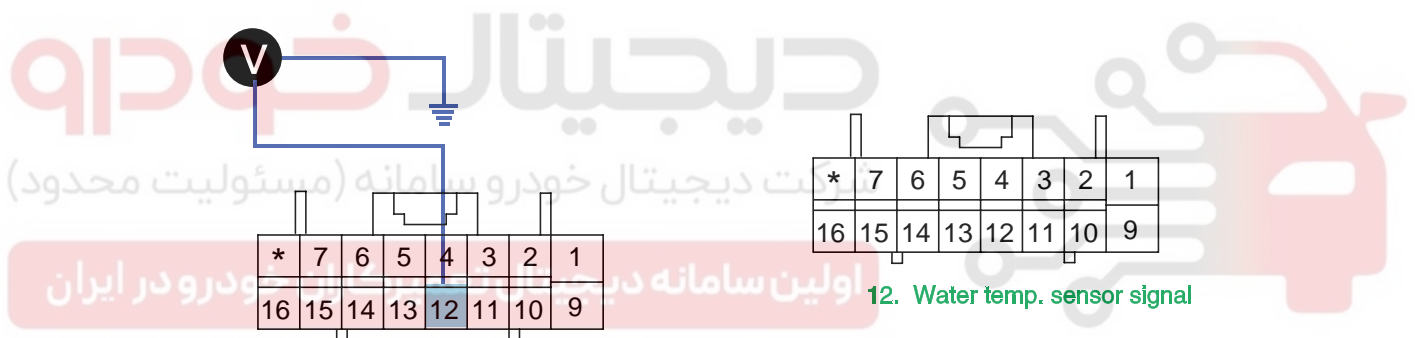

SGHHA6207L

- 4) Is the measured voltage within specifications?

YES

Check connectors for looseness, poor connection, bending, corrosion, contamination, deterioration, or damage. Repair or replace as necessary and then go to "Verification of Vehicle Repair" procedure.

NO

Substitute with a known-good A/C Control Unit and check for proper operation.

If the problem is corrected, replace A/C Control Unit and then go to "Verification of Vehicle Repair" procedure.

VERIFICATION OF VEHICLE REPAIR E60A09C9

After a repair, it is essential to verify that the fault has been corrected.

1. Connect scantool and select "Diagnostic Trouble Codes(DTCs)" mode and then clear DTC.
2. Operate the vehicle and monitor the DTC on the scantool.
3. Are any DTCs present?

BLOWER AND A/C CONTROLS (AUTOMATIC)

HA -33

YES

Go to the applicable troubleshooting procedure.

NO

System is performing to specification at this time.

دیجیتال خودرو

شرکت دیجیتال خودرو سامانه (مسئولیت محدود)

اولین سامانه دیجیتال تعمیرکاران خودرو در ایران



HA -34

HEATING, VENTILATION AND AIR CONDITIONING

DTC B1203 WATER TEMPERATURE SENSOR SHORT (LOW)

COMPONENT LOCATION EC6F9F36

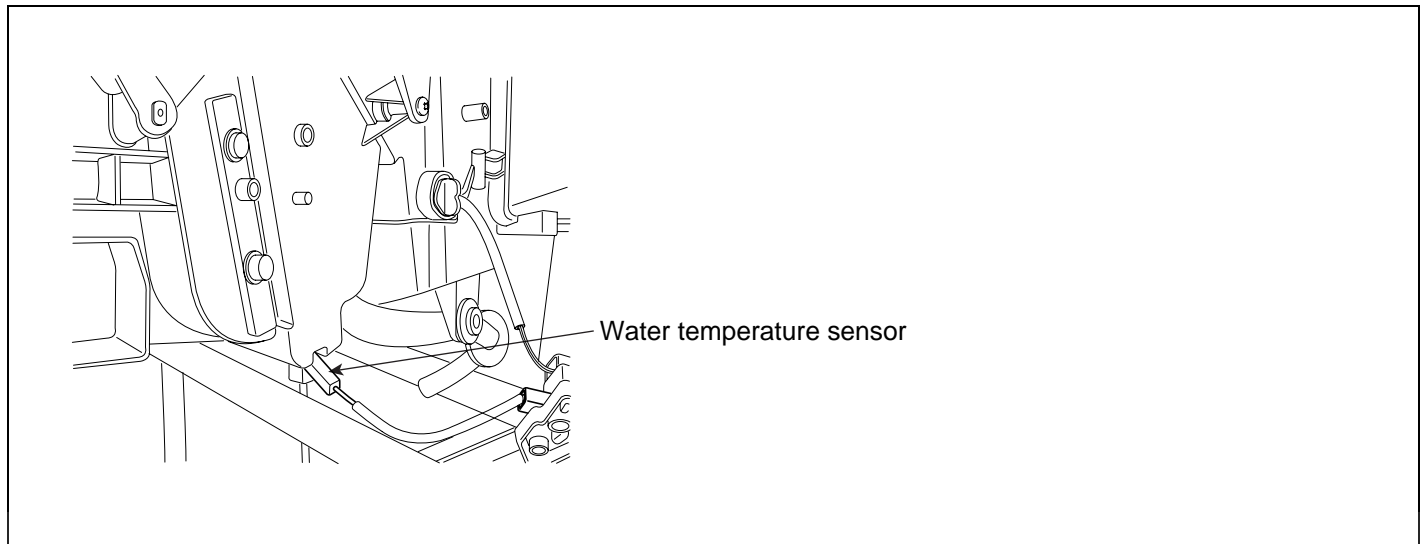

SGHHA6603L

GENERAL DESCRIPTION EFE4C535

Refer to DTC B1202.

DTC DESCRIPTION EA17C85B

The A/C controller sets DTC B1203 if there is a short circuit in water temp. sensor signal harness or the measured resistance value of sensor is less than threshold value(about 1.2k)

DTC DETECTING CONDITION EF2E3145

Item	Detecting Condition	Possible cause
DTC Strategy	<ul style="list-style-type: none"> Resistance check 	<ul style="list-style-type: none"> Short circuit in harness Faulty water temp. Sensor Faulty A/C control unit
Threshold value	<ul style="list-style-type: none"> < 1.2 k 	
Detecting time	<ul style="list-style-type: none"> 0.3 sec 	
FAIL SAFE	<ul style="list-style-type: none"> Control with the value of -2°C(28.4°F) 	

SPECIFICATION E6B0F9BF

Refer to DTC B1202.

MONITOR SCANTOOL DATA EADCD72B

1. Connect scantool to data link connector(DLC).
2. Engine "ON"
3. Monitor the "WATER TEMP. SENSOR" Parameter on the Scantool.

BLOWER AND A/C CONTROLS (AUTOMATIC)

HA -35

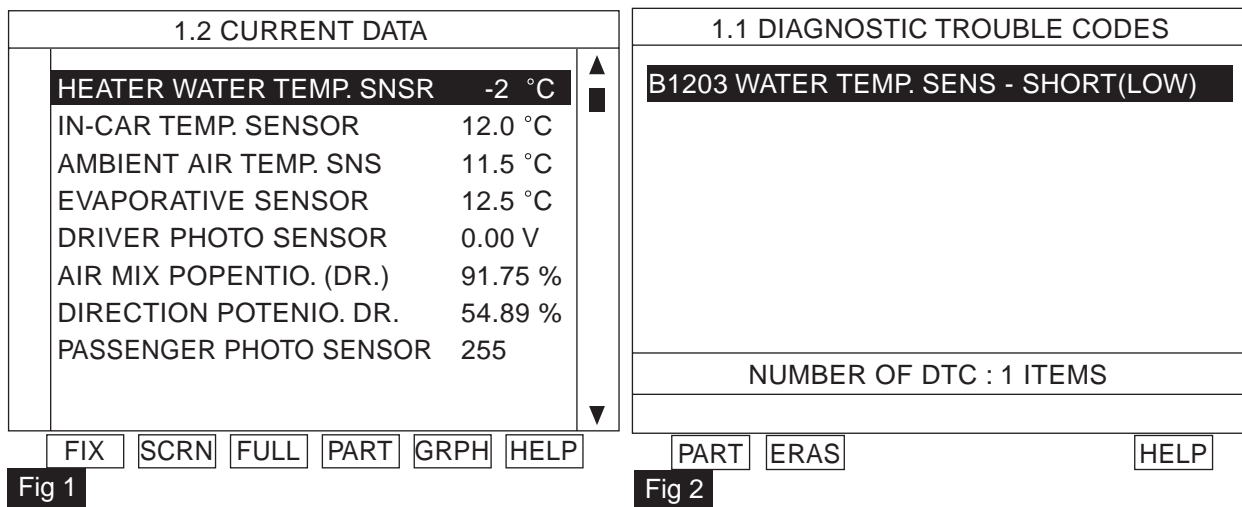

Fig 1 : The current data in abnormal state.

Fig 2 : DTC B1203.

EQRE513A

4. Are the DTC B1203 present and is parameter of "WATER TEMP. SENSOR" fixed?

Parameter of "WATER TEMP. SENSOR" will be fixed at -2 (28.4°F), if there is any fault in WATER TEMP. SENSOR.

YES

Go to "Inspection" procedure.

NO

Fault is intermittent caused by poor contact in the sensor's and/or A/C controller's connector or was repaired and A/C controller memory was not cleared. Thoroughly check connectors for looseness, poor connection, bending, corrosion, contamination, deterioration, or damage. Repair or replace as necessary and then go to "Verification of Vehicle Repair" procedure.

TERMINAL AND CONNECTOR INSPECTION

E4A5AB7F

Refer to DTC B1202.

SIGNAL CIRCUIT INSPECTION

E5290ACF

1. Check for short to ground in harness.
 - 1) Ignition "OFF"
 - 2) Disconnect water temp. sensor.
 - 3) Measure resistance between terminal "1" of water temp. sensor and chassis ground.

Specification : Approx.

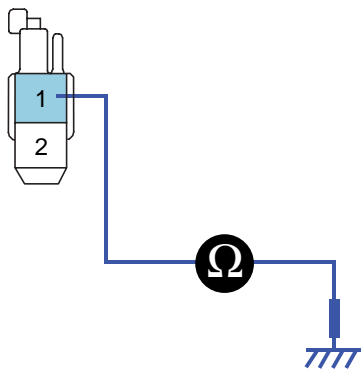

1. Water temp. sensor signal
2. Sensor ground

SGHHA6604L

4) Is the measured resistance within specifications?

YES

Go to "Component Inspection" procedure.

NO

Check for short to ground in harness. Repair as necessary and go to "Verification of Vehicle Repair" procedure.

COMPONENT INSPECTION

E688EEF4

Refer to DTC B1202.

VERIFICATION OF VEHICLE REPAIR

ED6AB445

Refer to DTC B1202.

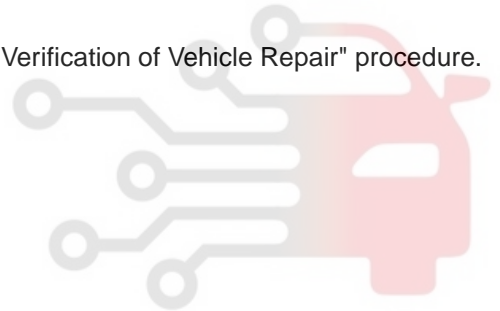

BLOWER AND A/C CONTROLS (AUTOMATIC)

HA -37

DTC B1204 AIR MIX POTENTIOMETER OPEN (LOW) - PASSENGER'S

COMPONENT LOCATION EDA2C3F2

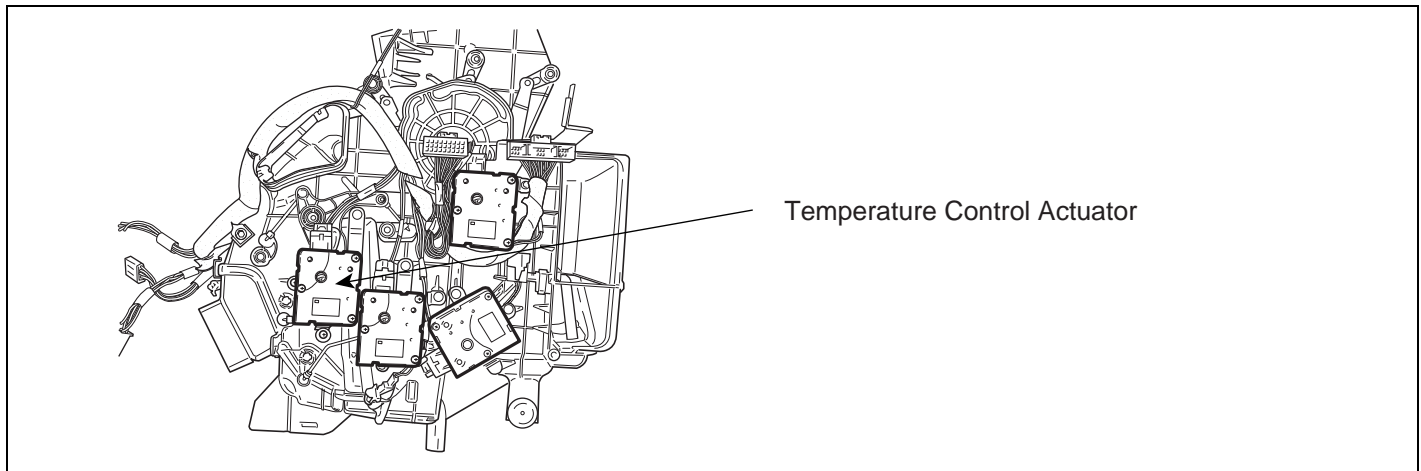

SGHHA6254L

GENERAL DESCRIPTION E6FDAF92

Temperature control actuator located at heater unit, regulates the temperature by the procedure as follows. Signal from control unit adjusts position of temp. door by operating temp. motor and then temperature will be regulated by the hot/cold air ratio decided by position of temp. door.

DTC DESCRIPTION E4F166A6

The A/C controller sets DTC B1204 if there is an open circuit or poor connection in the air mix potentiometer.

DTC DETECTING CONDITION E8DA37FC

Item	Detecting Condition	Possible cause
DTC Strategy	<ul style="list-style-type: none"> Voltage check 	<ul style="list-style-type: none"> Poor connection of connected part Open circuit in harness Short circuit in harness Faulty driver Air Mix potentiometer
Threshold value	<ul style="list-style-type: none"> < 0.1V 	
Detecting time	<ul style="list-style-type: none"> 0.3 sec 	
FAIL SAFE	<ul style="list-style-type: none"> If temperature setting 17~24.5°C(63~76°F) fix at max. cooling position. If temperature setting 25~32°C(77~90°F) fix at max. heating position. 	

HA -38

HEATING, VENTILATION AND AIR CONDITIONING

SPECIFICATION E927FFAF

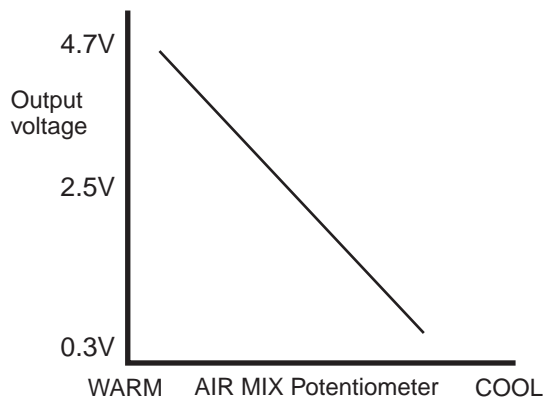

EQBF521B

MONITOR SCANTOOL DATA EF8DAA6E

1. Connect scantool to Data Link Connector(DLC).
2. Engine "ON"
3. Monitor the "Passenger's Air Mix Potentiometer" Parameter on the Scantool while operating temp. switch.

1.2 CURRENT DATA	
HEATER WATER TEMP.SNSR	13.0 °C
IN-CAR TEMP.SENSOR	12.0 °C
AMBIENT AIR TEMP.SNS	12.0 °C
EVAPORATIVE SENSOR	12.5 °C
DRIVER PHOTO SENSOR	0.00 V
AIR MIX POPENRIO.(PA.)	5.9 %
DIRECTION POTENIO.DR.	90.18 %
PASSENGER PHOTO SENSOR	255

Fig. 1

1.1 DIAGNOSTIC TROUBLE CODES	
B1204 AIR MIX P. - LOW INPUT	
NUMBER OF DTC : 1 ITEMS	

Fig. 2

Fig 1 : The current data in abnormal state.

Fig 2 : DTC B1204.

EQBF521K

4. Are the DTC B1204 present and is parameter of "Passenger's Air Mix Potentiometer" fixed?
Parameter of "Passenger's Air Mix Potentiometer" will be fixed at 100%(or any value above 90%), or 0% (or any value below 10%), if there is any fault in Passenger's Air Mix potentiometer.

YES

Go to "Inspection" procedure.

BLOWER AND A/C CONTROLS (AUTOMATIC)

HA -39

NO

Fault is intermittent caused by poor contact in the sensor's and/or A/C controller's connector or was repaired and A/C controller memory was not cleared. Thoroughly check connectors for looseness, poor connection, bending, corrosion, contamination, deterioration, or damage. Repair or replace as necessary and then go to "Verification of Vehicle Repair" procedure.

TERMINAL AND CONNECTOR INSPECTION E27080F9

1. Many malfunctions in the electrical system are caused by poor harness and terminals. Faults can also be caused by interference from other electrical systems, and mechanical or chemical damage.
2. Thoroughly check connectors for looseness, poor connection, bending, corrosion, contamination, deterioration, or damage.
3. Has a problem been found?

YES

Repair as necessary and go to "Verification of Vehicle Repair" procedure.

NO

Go to "Signal circuit inspection" procedure.

SIGNAL CIRCUIT INSPECTION EEC01ECA

1. Check for open in harness.
 - 1) Ignition "OFF"
 - 2) Disconnect Passenger's Air Mix potentiometer.
 - 3) Measure resistance between terminal "5" of Passenger's Air Mix Potentiometer and terminal "12" of A/C control unit.



Specification : Approx. 0

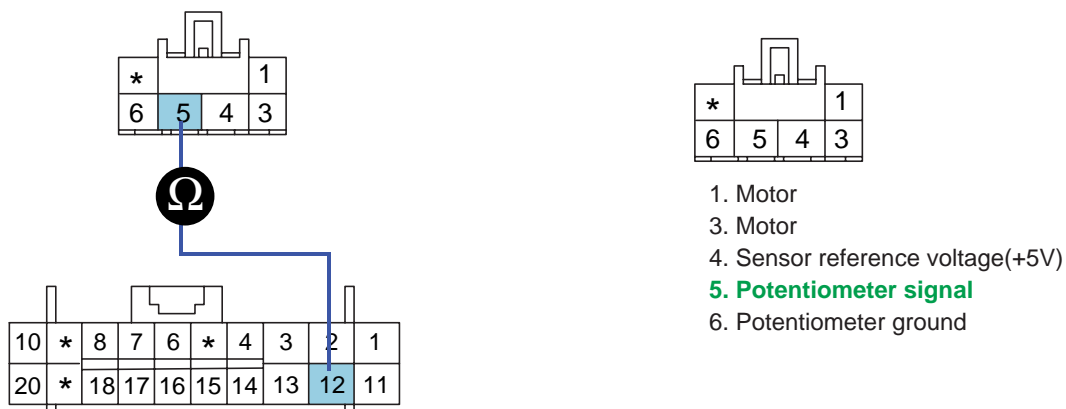

SGHHA6209L

HA -40

HEATING, VENTILATION AND AIR CONDITIONING

4) Is the measured resistance within specifications?

YES

Go to "Check for short to ground in harness" procedure.

NO

Check for open in signal harness. Repair as necessary and go to "Verification of Vehicle Repair" procedure.

2. Check for short to ground in harness.

- 1) Ignition "OFF"
- 2) Disconnect Passenger's Air Mix potentiometer.
- 3) Measure resistance between terminal "5" of Passenger's Air Mix Potentiometer and chassis ground.

Specification : Approx.

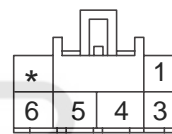
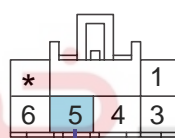

1. Motor
3. Motor
4. Sensor reference voltage(+5V)
5. Potentiometer signal
6. Potentiometer ground

SGHHA6210L

4) Is the measured resistance within specifications?

YES

Go to "Power circuit Inspection" procedure.

NO

Check for short to ground in signal harness. Repair as necessary and go to "Verification of Vehicle Repair" procedure.

POWER SUPPLY CIRCUIT INSPECTION EED3C936

1. Check for short or open in harness.

- 1) Ignition "ON"
- 2) Connect Passenger's Air Mix Potentiometer.
- 3) Measure voltage between terminal "4" of Passenger's Air Mix Potentiometer and chassis ground.

Specification : Approx. 5V

BLOWER AND A/C CONTROLS (AUTOMATIC)

HA -41

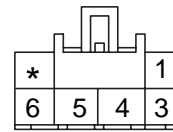
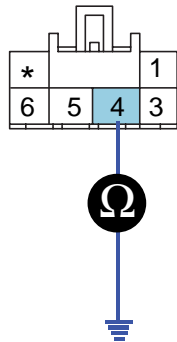

- 1. Motor
- 3. Motor
- 4. Sensor reference voltage(+5V)
- 5. Potentiometer signal
- 6. Potentiometer ground

SGHHA6211L

4) Is the measured voltage within specifications?

YES

Go to "Component inspection" procedure.

NO

Check for short or open in power harness. Repair as necessary and go to "Verification of Vehicle Repair" procedure.

COMPONENT INSPECTION

E3EE5ADD

1. Check actuator motor.

- 1) Ignition "OFF"
- 2) Disconnect Passenger's Air Mix Potentiometer.
- 3) Verify that the temperature actuator operates to the hot position when connecting 12V to the terminal "1" and grounding terminal "3".
- 4) Verify that the temperature actuator operates to the cool position when the connections are reversed.

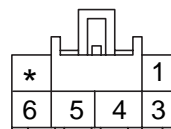
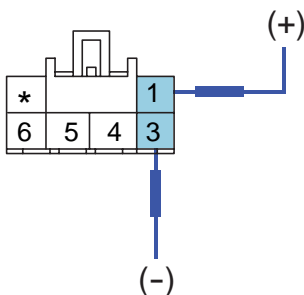

- 1. Motor
- 3. Motor
- 4. Sensor reference voltage(+5V)
- 5. Potentiometer signal
- 6. Potentiometer ground

SGHHA6212L

5) Does the actuator work properly?

HA -42

HEATING, VENTILATION AND AIR CONDITIONING

YES

Go to "Check potentiometer" procedure.

NO

Substitute with a known-good actuator and check for proper operation. If the problem is corrected, replace actuator and then go to "Verification of Vehicle Repair" procedure.

2. Check potentiometer

- 1) Ignition "ON"
- 2) Connect Passenger's Air Mix potentiometer.
- 3) Measure voltage between terminal "5" and "6" of Passenger's Air Mix potentiometer while operating the temp. switch.

Specification : Refer the specifications in fig 3)

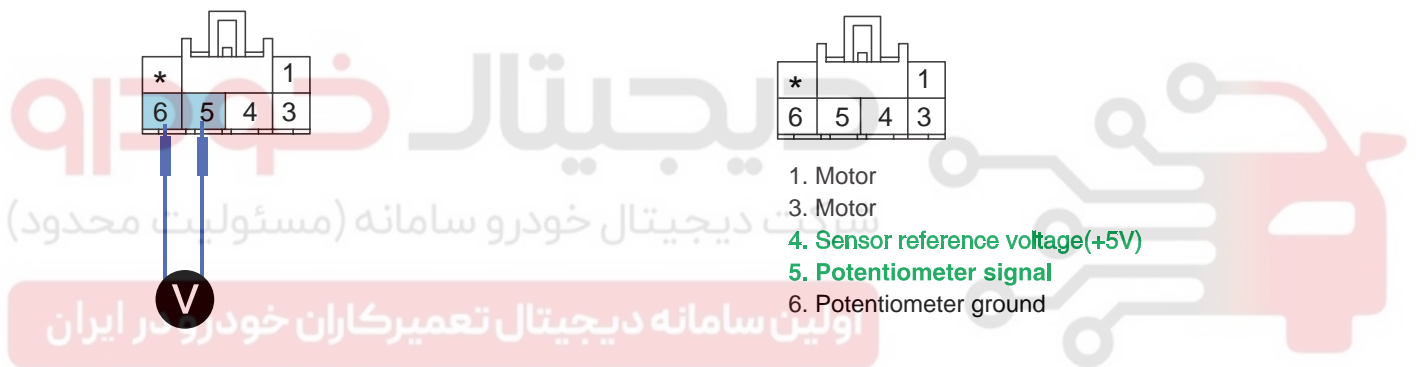

SGHHA6213L

Door position	Voltage (5-6)	Error detecting
MAX. Cooling	0.3 ± 0.15V	Low voltage : 0.08V or less
MAX. Heating	4.7 ± 0.15V	High voltage : 4.9V or more

BLOWER AND A/C CONTROLS (AUTOMATIC)

HA -43

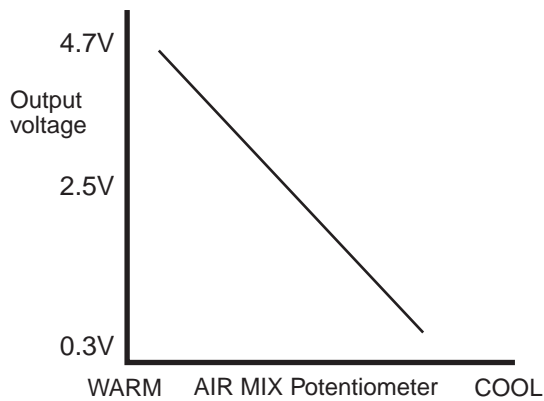

Fig. 3

Fig 3) Specifications : Voltage value of air mix potentiometer as a function of position of setting temperature.

EQBF521J

4) Is the measured voltage within specifications in fig3?

YES

Check connectors for looseness, poor connection, bending, corrosion, contamination, deterioration, or damage. Repair or replace as necessary and then go to "Verification of Vehicle Repair" procedure.

NO

Substitute with a known-good actuator and check for proper operation. If the problem is corrected, replace actuator and then go to "Verification of Vehicle Repair" procedure.

VERIFICATION OF VEHICLE REPAIR E960BEB

After a repair, it is essential to verify that the fault has been corrected.

1. Connect scantool and select "Diagnostic Trouble Codes(DTCs)" mode and then clear DTC.
2. Operate the vehicle and monitor the DTC on the scantool.
3. Are any DTCs present?

YES

Go to the applicable troubleshooting procedure.

NO

System is performing to specification at this time.

HA -44

HEATING, VENTILATION AND AIR CONDITIONING

DTC B1205 AIR MIX POTENTIOMETER SHORT (HIGH) - PASSENGER'S

COMPONENT LOCATION E08F7DFE

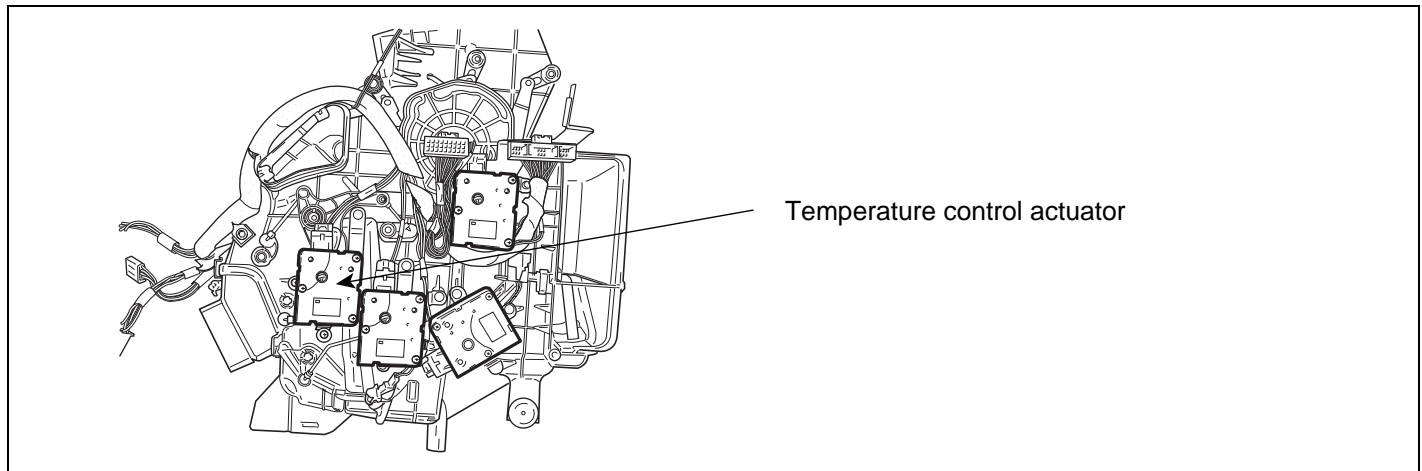

SGHHA6605L

GENERAL DESCRIPTION EBBBA148

Temperature control actuator located at heater unit, regulates the temperature by the procedure as follows. Signal from control unit adjusts position of temp. door by operating temp. motor and then temperature will be regulated by the hot/cold air ratio decided by position of temp. door.

DTC DESCRIPTION EEFEA86B

The A/C controller sets DTC B1205 if there is a short to power in the air mix potentiometer.

DTC DETECTING CONDITION E0C85E40

Item	Detecting Condition	Possible cause
DTC Strategy	<ul style="list-style-type: none"> Voltage check 	<ul style="list-style-type: none"> Short circuit in harness Faulty driver Air Mix potentiometer
Threshold value	<ul style="list-style-type: none"> > 4.9V 	
Detecting time	<ul style="list-style-type: none"> 0.3 sec 	
FAIL SAFE	<ul style="list-style-type: none"> If temperature setting 17~24.5°C(63~76°F) fix at max. cooling position. If temperature setting 25~32°C(77~90°F) fix at max. heating position. 	

BLOWER AND A/C CONTROLS (AUTOMATIC)

HA -45

SPECIFICATION EE47778F

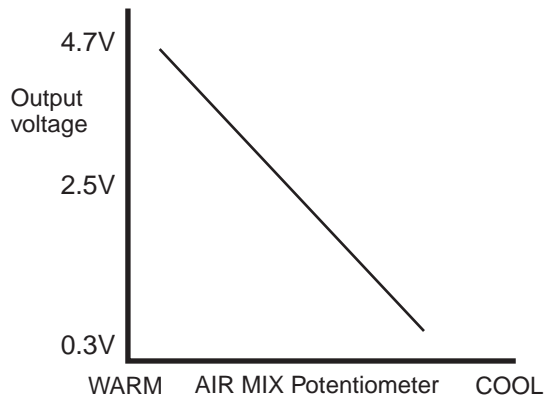

EQBF521B

MONITOR SCANTOOL DATA E7CFD25C

1. Connect scantool to Data Link Connector(DLC).
2. Engine "ON"
3. Monitor the "Passenger's Air Mix Potentiometer" Parameter on the Scantool while operating temp. switch.

1.2 CURRENT DATA	
HEATER WATER TEMP.SNSR	13.0 °C
IN-CAR TEMP.SENSOR	12.0 °C
AMBIENT AIR TEMP.SNS	12.0 °C
EVAPORATIVE SENSOR	12.5 °C
DRIVER PHOTO SENSOR	0.00 V
AIR MIX POPENATIO.(PA.)	91.75 %
DIRECTION POTENIO.DR.	90.18 %
PASSENGER PHOTO SENSOR	255

Fig. 1

1.1 DIAGNOSTIC TROUBLE CODES	
B1205 AIR MIX P. - HIGH INPUT	
NUMBER OF DTC : 1 ITEMS	

Fig. 2

Fig 1 : The current data in abnormal state.

Fig 2 : DTC B1205.

EQBF522F

4. Are the DTC B1205 present and is parameter of "Passenger's Air Mix potentiometer" fixed?
Parameter of "Passenger's Air Mix potentiometer" will be fixed at 100%(or any value above 90%), or 0% (or any value below 10%), if there is any fault in Passenger's Air Mix potentiometer.

YES

Go to "Inspection" procedure.

HA -46

HEATING, VENTILATION AND AIR CONDITIONING

NO

Fault is intermittent caused by poor contact in the sensor's and/or A/C controller's connector or was repaired and A/C controller memory was not cleared. Thoroughly check connectors for looseness, poor connection, bending, corrosion, contamination, deterioration, or damage. Repair or replace as necessary and then go to "Verification of Vehicle Repair" procedure.

TERMINAL AND CONNECTOR INSPECTION E283B9EA

1. Many malfunctions in the electrical system are caused by poor harness and terminals. Faults can also be caused by interference from other electrical systems, and mechanical or chemical damage.
2. Thoroughly check connectors for looseness, poor connection, bending, corrosion, contamination, deterioration, or damage.
3. Has a problem been found?

YES

Repair as necessary and go to "Verification of Vehicle Repair" procedure.

NO

Go to "Signal circuit inspection" procedure.

SIGNAL CIRCUIT INSPECTION E5E91EAA

1. Check for short in harness.
 - 1) Ignition "OFF"
 - 2) Disconnect Passenger's Air Mix potentiometer.
 - 3) Measure resistance between terminal "4" and "5" of Passenger's Air Mix potentiometer.

Specification : Approx.

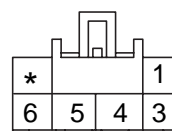
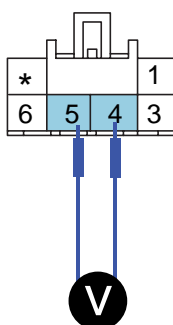

1. Motor
3. Motor
4. Sensor reference voltage(+5V)
5. Potentiometer signal
6. Potentiometer ground

SGHHA6214L

BLOWER AND A/C CONTROLS (AUTOMATIC)

HA -47

4) Is the measured resistance within specifications?

YES

Go to "Ground circuit Inspection" procedure.

NO

Check for short to power harness in signal harness. Repair as necessary and go to "Verification of Vehicle Repair" procedure.

GROUND CIRCUIT INSPECTION EE38C85A

1. Check for open in harness.

- 1) Ignition "OFF"
- 2) Disconnect Passenger's Air Mix Potentiometer.
- 3) Measure resistance between terminal "6" of Passenger's Air Mix Potentiometer and chassis ground.

Specification : Approx. 0

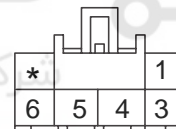

1. Motor
3. Motor
4. Sensor reference voltage(+5V)
5. Potentiometer signal
6. Potentiometer ground

SGHHA6215L

4) Is the measured resistance within specifications?

YES

Go to "Component Inspection" procedure.

NO

Check for open in ground harness. Repair as necessary and go to "Verification of Vehicle Repair" procedure.

COMPONENT INSPECTION EE9D88DB

1. Check actuator motor.

- 1) Ignition "OFF"
- 2) Disconnect Passenger's Air Mix Potentiometer.

HA -48

HEATING, VENTILATION AND AIR CONDITIONING

- 3) Verify that the temperature actuator operates to the hot position when connecting 12V to the terminal "1" and grounding terminal "3".
- 4) Verify that the temperature actuator operates to the cool position when the connections are reversed.

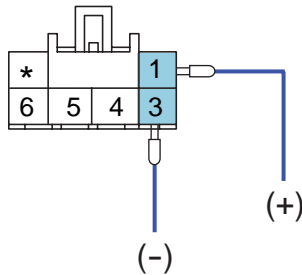

- 1. Motor
- 3. Motor
- 4. Sensor reference voltage(+5V)
- 5. Potentiometer signal
- 6. Potentiometer ground

SGHHA6606L

- 5) Does the actuator work properly?

YES

Go to "Check potentiometer" procedure.

NO

Substitute with a known-good actuator and check for proper operation. If the problem is corrected, replace actuator and then go to "Verification of Vehicle Repair" procedure.

- 2) Check potentiometer
 - 1) Ignition "ON"
 - 2) Connect Passenger's Air Mix potentiometer.
 - 3) Measure voltage between terminal "5" and "6" of Passenger's Air Mix potentiometer while operating the temp. switch.

Specification : Refer the specifications in fig 3)

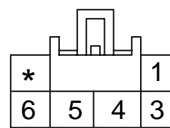
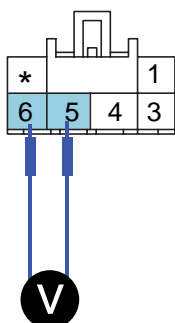

- 1. Motor
- 3. Motor
- 4. Sensor reference voltage(+5V)
- 5. Potentiometer signal
- 6. Potentiometer ground

SGHHA6213L

Door position	Voltage (5-6)	Error detecting
MAX. Cooling	0.3 ± 0.15V	Low voltage : 0.08V or less
MAX. Heating	4.7 ± 0.15V	High voltage : 4.9V or more

BLOWER AND A/C CONTROLS (AUTOMATIC)

HA -49

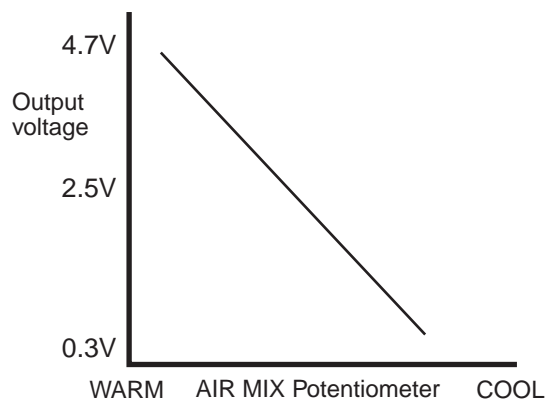

Fig. 3

Fig 3) Specifications : Voltage value of air mix potentiometer as a function of position of setting temperature.

EQBF521J

4) Is the measured voltage within specifications in fig3?

YES

Check connectors for looseness, poor connection, bending, corrosion, contamination, deterioration, or damage. Repair or replace as necessary and then go to "Verification of Vehicle Repair" procedure.

NO

Substitute with a known-good actuator and check for proper operation. If the problem is corrected, replace actuator and then go to "Verification of Vehicle Repair" procedure.

VERIFICATION OF VEHICLE REPAIR ECF5DABA

After a repair, it is essential to verify that the fault has been corrected.

1. Connect scantool and select "Diagnostic Trouble Codes(DTCs)" mode and then clear DTC.
2. Operate the vehicle and monitor the DTC on the scantool.
3. Are any DTCs present?

YES

Go to the applicable troubleshooting procedure.

NO

System is performing to specification at this time.

HA -50

HEATING, VENTILATION AND AIR CONDITIONING

DTC B1206 DIRECTION POTENTIOMETER OPEN (LOW)-PASSENGER

COMPONENT LOCATION E2CF109C

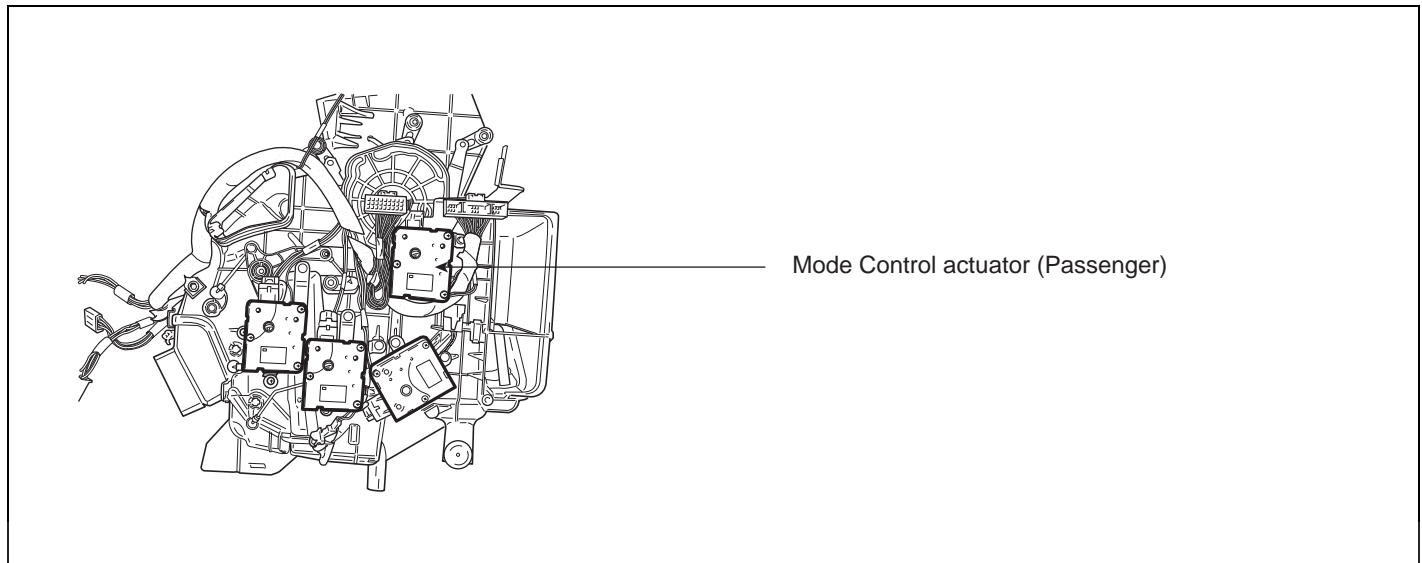

SGHHA6258L

GENERAL DESCRIPTION E04D3B49

The mode control actuator mounted on heater unit, adjusts position of mode door by operating Direction Motor based on signal of A/C control unit. Pressing mode select switch makes the mode control actuator shift in order of vent B/L floor mix.

DTC DESCRIPTION E609A095

The A/C controller sets DTC B1249 if there is an open circuit or poor connection in the Direction potentiometer.

DTC DETECTING CONDITION EDF3DF5B

Item	Detecting Condition	Possible cause
DTC Strategy	<ul style="list-style-type: none"> Voltage check 	<ul style="list-style-type: none"> Poor connection of connected part Open circuit in harness Short circuit in harness Faulty driver direction potentiometer
Threshold value	<ul style="list-style-type: none"> < 0.1V 	
Detecting time	<ul style="list-style-type: none"> 0.3 sec 	
FAIL SAFE	<ul style="list-style-type: none"> Fix vent position, while selecting vent mode. Fix defrost position while selecting except vent mode. 	

BLOWER AND A/C CONTROLS (AUTOMATIC)

HA -51

SPECIFICATION ED5817D7

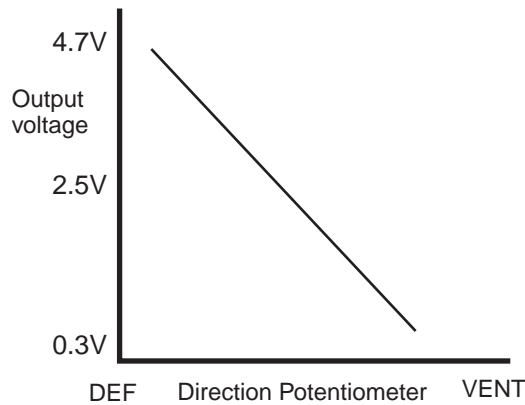

EQBF523B

MONITOR SCANTOOL DATA E43E3AD4

1. Connect scantool to Data Link Connector(DLC).
2. Engine "ON"
3. Monitor the "P. DIRECTION POTENTIO." parameter on the scantool while operating mode switch.

1.2 CURRENT DATA	
HEATER WATER TEMP.SNSR	13.0 °C
IN-CAR TEMP.SENSOR	11.5 °C
AMBIENT AIR TEMP.SNS	12.0 °C
EVAPORATIVE SENSOR	13.0 °C
DRIVER PHOTO SENSOR	0.00 V
AIR MIX POPTENTIO.(DR.)	92.54 %
DIRECTION POTENIO.P.	1.96 %
PASSENGER PHOTO SENSOR	255

Fig. 1

1.1 DIAGNOSTIC TROUBLE CODES	
B1249 DIRECTION P. - LOW INPUT	
NUMBER OF DTC : 1 ITEMS	

Fig. 2

Fig 1 : The current data in abnormal state.

Fig 2 : DTC B1249.

SGHHA6607L

4. Are the DTC B1249 present and is parameter of "P. DIRECTION POTENTIO." fixed?
Parameter of "P. DIRECTION POTENTIO." will be fixed at 100%(or any value above 90%), or 0% (or any value below 10%), if there is any fault in Driver Direction potentiometer.

YES

Go to "Inspection" procedure.

HA -52

HEATING, VENTILATION AND AIR CONDITIONING

NO

Fault is intermittent caused by poor contact in the sensor's and/or A/C controller's connector or was repaired and A/C controller memory was not cleared. Thoroughly check connectors for looseness, poor connection, bending, corrosion, contamination, deterioration, or damage. Repair or replace as necessary and then go to "Verification of Vehicle Repair" procedure.

TERMINAL AND CONNECTOR INSPECTION EEA42FB4

1. Many malfunctions in the electrical system are caused by poor harness and terminals. Faults can also be caused by interference from other electrical systems, and mechanical or chemical damage.
2. Thoroughly check connectors for looseness, poor connection, bending, corrosion, contamination, deterioration, or damage.
3. Has a problem been found?

YES

Repair as necessary and go to "Verification of Vehicle Repair" procedure.

NO

Go to "Signal circuit inspection" procedure.

SIGNAL CIRCUIT INSPECTION E800C316

1. Check for open in harness.
 - 1) Ignition "OFF"
 - 2) Disconnect Passenger mode Actuator.
 - 3) Measure resistance between terminal "5" of Passenger Direction potentiometer and terminal "2" of A/C control unit.

Specification : Approx. 0

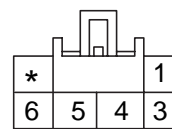
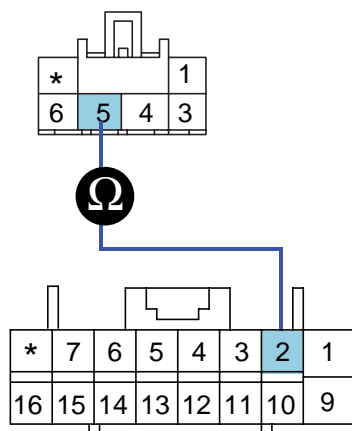

1. Motor
3. Motor
4. Sensor reference voltage(+5V)
5. Potentiometer signal
6. Potentiometer ground

SGHHA6216L

BLOWER AND A/C CONTROLS (AUTOMATIC)

HA -53

4) Is the measured resistance within specifications?

YES

Go to "Check for short to ground in harness" procedure.

NO

Check for open in signal harness. Repair as necessary and go to "Verification of Vehicle Repair" procedure.

2. Check for short to ground in harness.

- 1) Ignition "ON"
- 2) Disconnect Passenger mode Actuator.
- 3) Measure resistance between terminal "5" of Passenger Direction potentiometer and chassis ground.

Specification : Approx.

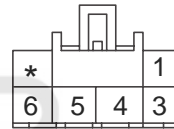
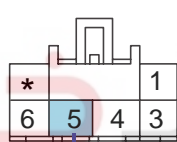

1. Motor
3. Motor
4. Sensor reference voltage(+5V)
5. Potentiometer signal
6. Potentiometer ground

SGHHA6210L

4) Is the measured resistance within specifications?

YES

Go to "Power circuit Inspection" procedure.

NO

Check for short to ground in signal harness. Repair as necessary and go to "Verification of Vehicle Repair" procedure.

POWER SUPPLY CIRCUIT INSPECTION E6B67647

1. Check for short or short in harness.

- 1) Ignition "ON"
- 2) Connect Passenger Direction potentiometer.
- 3) Measure voltage between terminal "4" of Passenger Direction potentiometer and chassis ground.

Specification : Approx. 5V

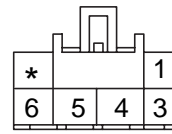
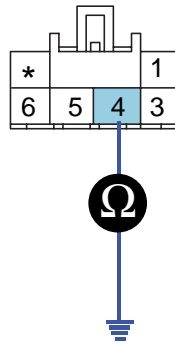

- 1. Motor
- 3. Motor
- 4. Sensor reference voltage(+5V)
- 5. Potentiometer signal
- 6. Potentiometer ground

SGHHA6211L

4) Is the measured voltage within specifications?

YES

Go to "Component Inspection" procedure.

NO

Check for short or open in power harness. Repair as necessary and go to "Verification of Vehicle Repair" procedure.

COMPONENT INSPECTION E4817480

1. Check actuator.
 - 1) Ignition "OFF"
 - 2) Disconnect Passenger Direction potentiometer.
 - 3) Verify that the mode actuator operates to the vent mode when connecting 12V to the terminal "1" and grounding terminal "3".
 - 4) Verify that the mode actuator operates to the def mode when the connections are reversed.

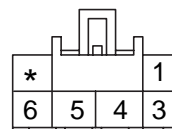
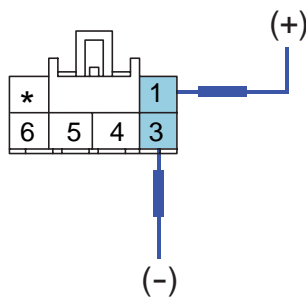

- 1. Motor
- 3. Motor
- 4. Sensor reference voltage(+5V)
- 5. Potentiometer signal
- 6. Potentiometer ground

SGHHA6212L

5) Does the actuator work properly?

BLOWER AND A/C CONTROLS (AUTOMATIC)

HA -55

YES

Go to "Check potentiometer" procedure.

NO

Substitute with a known-good actuator and check for proper operation. If the problem is corrected, replace actuator and then go to "Verification of Vehicle Repair" procedure.

2. Check potentiometer

- 1) Ignition "ON"
- 2) Connect Passenger Direction potentiometer.
- 3) Measure voltage between terminal "5" and "6" of Passenger Direction potentiometer as the mode switch is operated.

Specification : Refer the specifications in fig 3

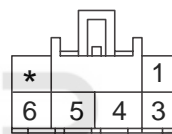

1. Motor
3. Motor
4. Sensor reference voltage(+5V)
5. Potentiometer signal
6. Potentiometer ground

SGHHA6213L

Door position	Voltage (5-6)	Error detecting
VENT	0.3 ± 0.15V	Under voltage : 0.08V or less Over voltage : 4.92V or more
BI-LEVEL(1)	1.35 ± 0.4V	
BI-LEVEL(2)	2.25 ± 0.4V	
FLOOR	3.0 ± 0.4V	
MIX	3.6 ± 0.4V	
DEF	4.7 ± 0.15V	

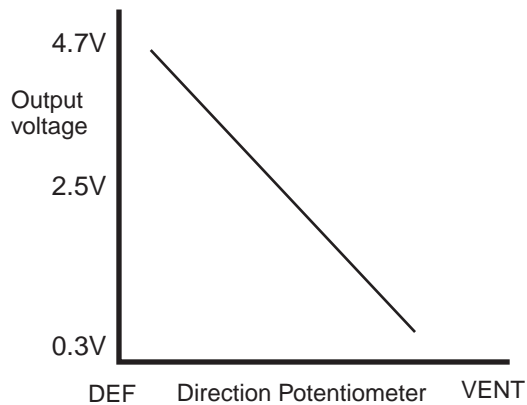

Fig. 3

Fig 3) Specifications : Voltage value as a function of position of direction potentiometer.

EQBF523J

4) Is the measured voltage within specifications in fig3?

YES

Check connectors for looseness, poor connection, bending, corrosion, contamination, deterioration, or damage. Repair or replace as necessary and then go to "Verification of Vehicle Repair" procedure.

NO

Substitute with a known-good actuator and check for proper operation. If the problem is corrected, replace actuator and then go to "Verification of Vehicle Repair" procedure.

VERIFICATION OF VEHICLE REPAIR EF7E9A90

After a repair, it is essential to verify that the fault has been corrected.

1. Connect scantool and select "Diagnostic Trouble Codes(DTCs)" mode and then clear DTC.
2. Operate the vehicle and monitor the DTC on the scantool.
3. Are any DTCs present?

YES

Go to the applicable troubleshooting procedure.

NO

System is performing to specification at this time.

BLOWER AND A/C CONTROLS (AUTOMATIC)

HA -57

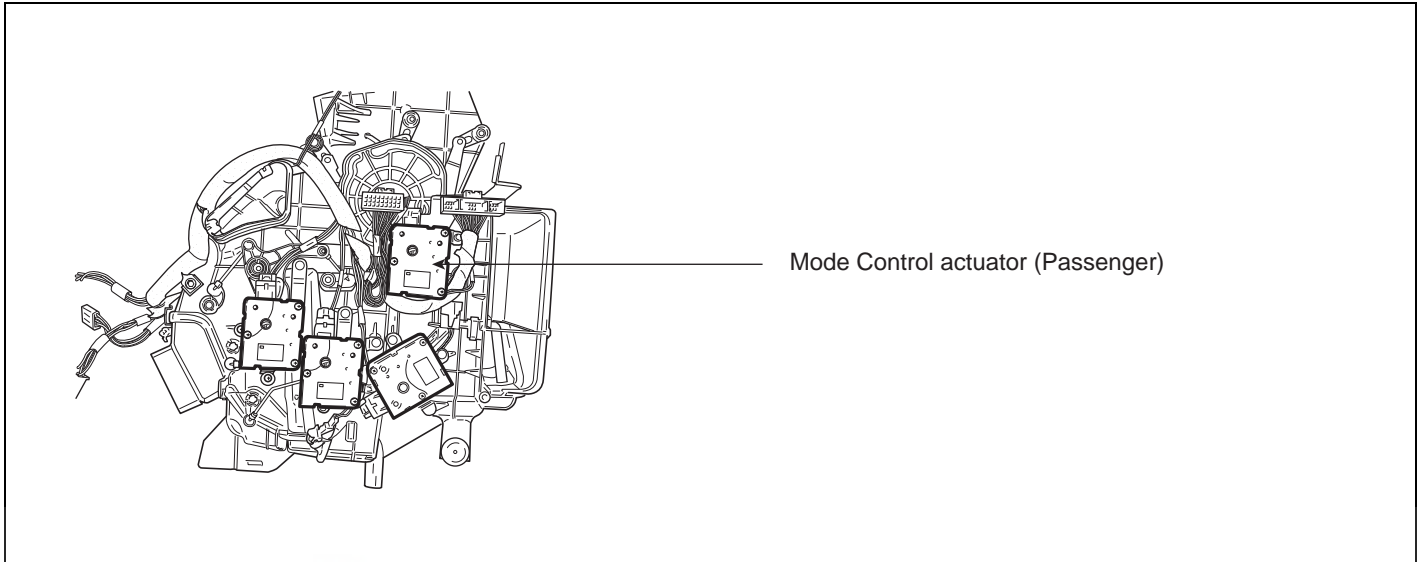
DTC B1207 DIRECTION POTENTIOMETER SHORT (HIGH)-PASSENGER**COMPONENT LOCATION** E5FACC3E**GENERAL DESCRIPTION** E3BF43D2

Refer to DTC B1206.

DTC DESCRIPTION E5926EB1

The A/C controller sets DTC B1207 if there is a short to power in the Direction potentiometer.

DTC DETECTING CONDITION E7928F7D

Item	Detecting Condition	Possible cause
DTC Strategy	<ul style="list-style-type: none"> Voltage check 	<ul style="list-style-type: none"> Short circuit in harness Faulty driver direction potentiometer Open circuit in harness
Threshold value	<ul style="list-style-type: none"> > 4.9V 	
Detecting time	<ul style="list-style-type: none"> 0.3 sec 	
FAIL SAFE	<ul style="list-style-type: none"> Fix vent position 	

SPECIFICATION E985515B

Refer to DTC B1206.

MONITOR SCANTOOL DATA EA8681EB

1. Connect scantool to Data Link Connector(DLC).
2. Engine "ON"
3. Monitor the "DR. DIRECTION POTENTIO." parameter on the scantool while operating mode switch.

1.2 CURRENT DATA	
HEATER WATER TEMP.SNSR	13.0 °C ▲
IN-CAR TEMP.SENSOR	11.5 °C
AMBIENT AIR TEMP.SNS	12.0 °C
EVAPORATIVE SENSOR	13.0 °C ■
DRIVER PHOTO SENSOR	0.00 V
AIR MIX POENTIO.(PA.)	92.54 %
DIRECTION POTENIO.PA.	100 %
PASSENGER PHOTO SENSOR	255 ▼

FIX SCRN FULL PART GRPH HELP

Fig 1

1.1 DIAGNOSTIC TROUBLE CODES
B1207 DIRECTION P. - HIGH INPUT
NUMBER OF DTC : 1 ITEMS

PART ERAS HELP

Fig 2

Fig 1 : The current data in abnormal state.

Fig 2 : DTC B1207.

LQKG990Q

4. Are the DTC B1207 present and is parameter of "DR. DIRECTION POTENTIO." fixed?
 Parameter of "DR. DIRECTION POTENTIO." will be fixed at 100%(or any value above 90%), or 0% (or any value below 10%), if there is any fault in Driver Direction potentiometer.

YES

Go to "Inspection" procedure.

NO

Fault is intermittent caused by poor contact in the sensor's and/or A/C controller's connector or was repaired and A/C controller memory was not cleared. Thoroughly check connectors for looseness, poor connection, bending, corrosion, contamination, deterioration, or damage. Repair or replace as necessary and then go to "Verification of Vehicle Repair" procedure.

TERMINAL AND CONNECTOR INSPECTION E83DF7F8

Refer to DTC B1206.

SIGNAL CIRCUIT INSPECTION EC0937E1

1. Check for short in harness.
 - 1) Ignition "OFF"
 - 2) Disconnect Passenger mode Actuator.
 - 3) Measure resistance between terminal "4" and "5" of Passenger Direction potentiometer.

Specification : Approx.

BLOWER AND A/C CONTROLS (AUTOMATIC)

HA -59

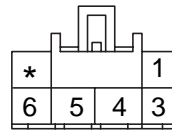
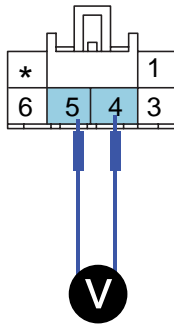

- 1. Motor
- 3. Motor
- 4. Sensor reference voltage(+5V)
- 5. Potentiometer signal
- 6. Potentiometer ground

SGHHA6214L

4) Is the measured resistance within specifications?

YES

Go to "Ground circuit inspection" procedure.

NO

Check for open in signal harness. Repair as necessary and go to "Verification of Vehicle Repair" procedure.

GROUND CIRCUIT INSPECTION

E4F4EE2B

1. Check for open in ground harness.

- 1) Ignition "OFF"
- 2) Disconnect Passenger mode Actuator.
- 3) Measure resistance between terminal "6" of evaporator sensor and chassis ground.

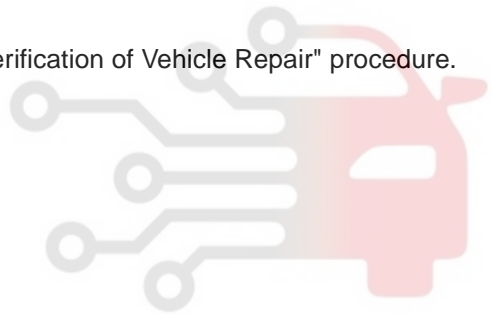

Specification :Approx. 0

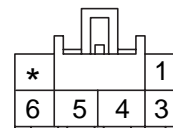
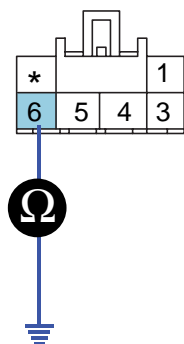

- 1. Motor
- 3. Motor
- 4. Sensor reference voltage(+5V)
- 5. Potentiometer signal
- 6. Potentiometer ground

SGHHA6215L

HA -60

HEATING, VENTILATION AND AIR CONDITIONING

4) Is the measured resistance within specifications?

YES

Go to "Component Inspection " procedure.

NO

Check for open in ground harness. Repair as necessary and go to "Verification of Vehicle Repair" procedure.

COMPONENT INSPECTION EE485422

Refer to DTC B1206.

VERIFICATION OF VEHICLE REPAIR E72F36B6

Refer to DTC B1206.

دیجیتال خودرو

شرکت دیجیتال خودرو سامانه (مسئولیت محدود)

اولین سامانه دیجیتال تعمیرکاران خودرو در ایران



BLOWER AND A/C CONTROLS (AUTOMATIC)

HA -61

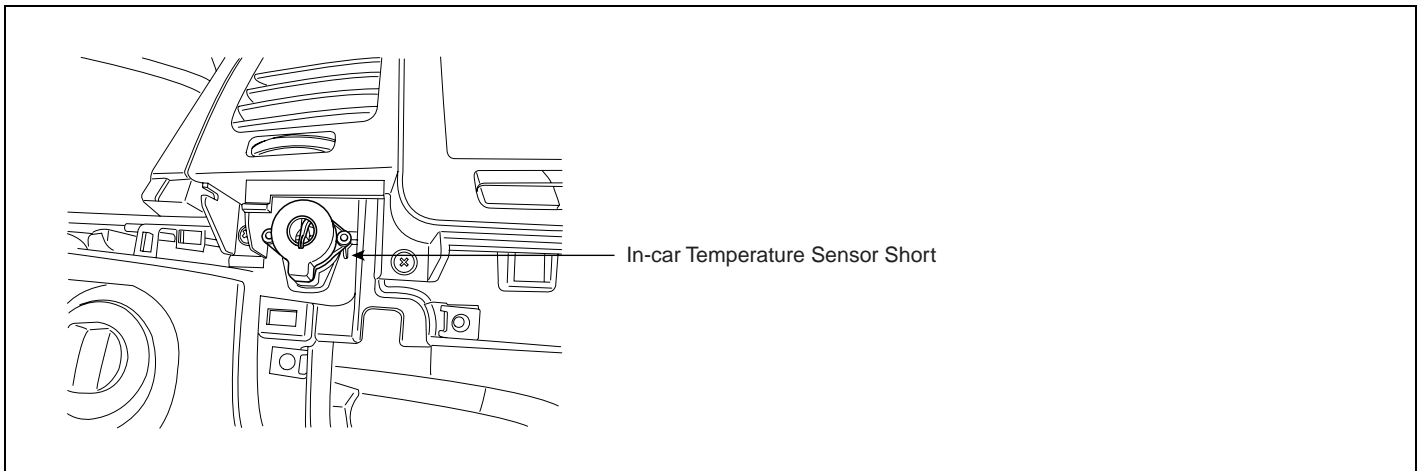
DTC B1233 IN-CAR TEMPERATURE SENSOR SHORT (LOW)**COMPONENT LOCATION** E5ADDDA8

SGHHA6260L

GENERAL DESCRIPTION EC43DDF5

The incar temperature sensor located at crush pad, control unit contains a thermistor which measures the temperature of the inside. The signal, decided by the resistance value which changes in accordance with perceived inside temperature, is delivered to heater control unit and according to this signal, the control unit regulates incar temperature to intended value.

DTC DESCRIPTION EB63EFE3

The A/C controller sets DTC B1233 if there is a short circuit in incar temp. sensor signal harness or the measured resistance value of sensor is less than threshold value (about 3k)

DTC DETECTING CONDITION E1046384

Item	Detecting Condition	Possible cause
DTC Strategy	• Resistance check	<ul style="list-style-type: none"> • Short circuit in harness • Faulty incar temp. Sensor • Faulty A/C control unit
Threshold value	• < 3 k	
Detecting time	• 0.3 sec	
FAIL SAFE	• Control with the value of 25°C(77°F)	

SPECIFICATION E4823648

Temperature[°C(°F)]	Resistance(k)	Temperature[°C(°F)]	Resistance(k)
-20 (-4)	290.22	20 (68)	37.49
-10 (14)	165.0	30 (86)	24.17
0(32)	97.83	40 (104)	15.99
10 (50)	59.66	50 (122)	10.82

HA -62

HEATING, VENTILATION AND AIR CONDITIONING

MONITOR SCANTOOL DATA E2472961

1. Connect scantool to data link connector(DLC).
2. Engine "ON"
3. Monitor the "INCAR TEMP. SENSOR" Parameter on the Scantool.

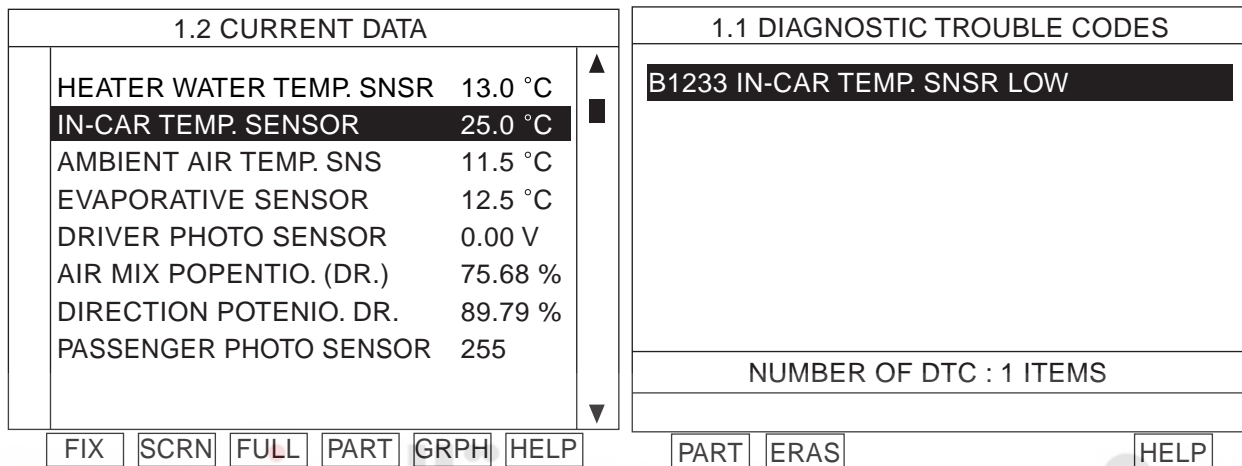

Fig 1

Fig 2

Fig 1 : The current data in abnormal state.

Fig 2 : DTC B1233.

4. Are the DTC B1233 present and is parameter of "INCAR TEMP. SENSOR" fixed?
 Parameter of "INCAR TEMP. SENSOR" will be fixed at 25 (77.), if there is any fault in INCAR TEMP. SENSOR.

YES

Go to "Inspection" procedure.

NO

Fault is intermittent caused by poor contact in the sensor's and/or A/C controller's connector or was repaired and A/C controller memory was not cleared. Thoroughly check connectors for looseness, poor connection, bending, corrosion, contamination, deterioration, or damage. Repair or replace as necessary and then go to "Verification of Vehicle Repair" procedure.

TERMINAL AND CONNECTOR INSPECTION EB821E5B

1. Many malfunctions in the electrical system are caused by poor harness and terminals. Faults can also be caused by interference from other electrical systems, and mechanical or chemical damage.
2. Thoroughly check connectors for looseness, poor connection, bending, corrosion, contamination, deterioration, or damage.
3. Has a problem been found?

YES

Repair as necessary and go to "Verification of Vehicle Repair" procedure.

BLOWER AND A/C CONTROLS (AUTOMATIC)

HA -63

NO

Go to "Signal circuit inspection" procedure.

SIGNAL CIRCUIT INSPECTION EBF88FB5

1. Check for short to ground in harness.
 - 1) Ignition "OFF"
 - 2) Disconnect incar sensor.
 - 3) Measure resistance between terminal "3" of incar sensor and chassis ground.

Specification : Approx.

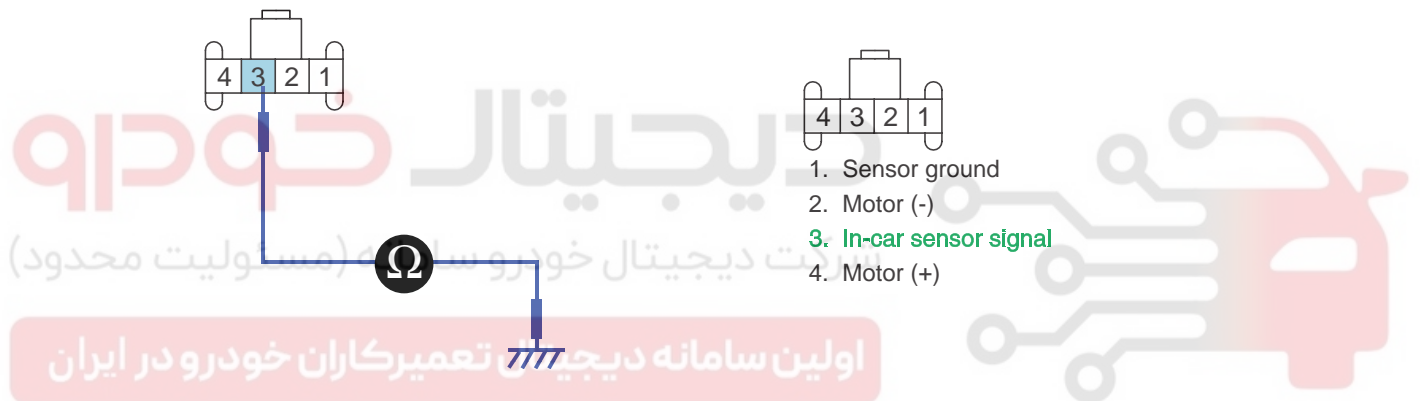

SGHHA6217L

- 4) Is the measured resistance within specifications?

YES

Go to "Component Inspection" procedure.

NO

Check for short to ground in harness. Repair as necessary and go to "Verification of Vehicle Repair" procedure.

COMPONENT INSPECTION E6BB9B31

1. Check incar temp. sensor.
 - 1) Ignition "OFF"
 - 2) Disconnect incar sensor.
 - 3) Measure resistance between terminal "1" and "3" of incar sensor.

Specification : Refer the specifications in fig 3.

HA -64

HEATING, VENTILATION AND AIR CONDITIONING

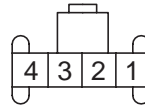
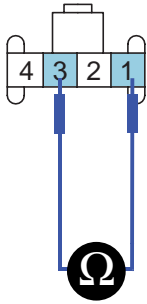

1. Sensor ground
2. Motor (-)
3. In-car sensor signal
4. Motor (+)

SGHHA6218L

Temperature[°C(°F)]	Resistance(k)	Temperature[°C(°F)]	Resistance(k)
-20 (-4)	290.22	20 (68)	37.49
-10 (14)	165.0	30 (86)	24.17
0(32)	97.83	40 (104)	15.99
10 (50)	59.66	50 (122)	10.82

- 4) Is the measured resistance within specifications in fig3? (tolerance limits $\pm 3\%$)

YES

شرکت دیجیتال خودرو (مسئولیت محدود)
Go to "Check A/C Control Unit" procedure.

اولین سامانه دیجیتال تعمیرکاران خودرو **NO** ران

Substitute with a known-good incar sensor and check for proper operation.

If the problem is corrected, replace incar sensor and then go to "Verification of Vehicle Repair" procedure.

2. Check A/C Control Unit

- 1) Engine "ON"
- 2) Disconnect incar sensor.
- 3) Measure Voltage between terminal "4" of A/C Control Unit and chassis ground.

Specification : Approx. 5V

BLOWER AND A/C CONTROLS (AUTOMATIC)

HA -65

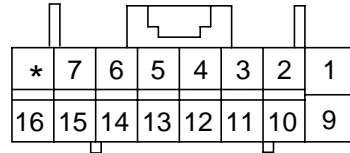
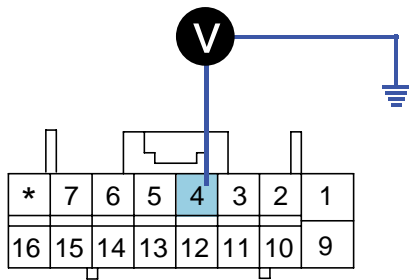

4. Incar sensor temp. signal

SGHHA6219L

4) Is the measured voltage within specifications?

YES

Check connectors for looseness, poor connection, bending, corrosion, contamination, deterioration, or damage. Repair or replace as necessary and then go to "Verification of Vehicle Repair" procedure.

NO

Substitute with a known-good A/C Control Unit and check for proper operation.

If the problem is corrected, replace A/C Control Unit and then go to "Verification of Vehicle Repair" procedure.

VERIFICATION OF VEHICLE REPAIR E5F6DCB4

After a repair, it is essential to verify that the fault has been corrected.

1. Connect scantool and select "Diagnostic Trouble Codes(DTCs)" mode and then clear DTC.
2. Operate the vehicle and monitor the DTC on the scantool.
3. Are any DTCs present?

YES

Go to the applicable troubleshooting procedure.

NO

System is performing to specification at this time.

HA -66

HEATING, VENTILATION AND AIR CONDITIONING

DTC B1234 IN-CAR TEMPERATURE SENSOR OPEN (HIGH)

COMPONENT LOCATION EBD12CCB

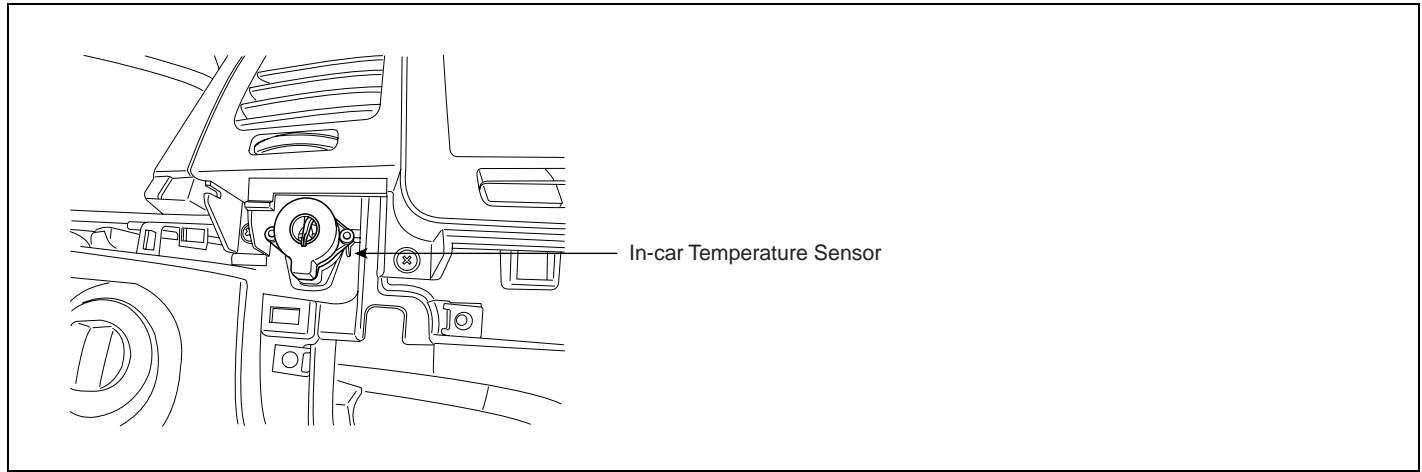

SGHHA6131L

GENERAL DESCRIPTION E9F794B3

Refer to DTC B1233.

DTC DESCRIPTION E11DE569

The A/C controller sets DTC B1234 if there is an open circuit in incar temp. sensor signal harness or the measured resistance value of sensor is more than threshold value(about 528k)

DTC DETECTING CONDITION E854B0E4

Item	Detecting Condition	Possible cause
DTC Strategy	<ul style="list-style-type: none"> Resistance check 	<ul style="list-style-type: none"> Open Circuit in harness Faulty incar temp. Sensor Faulty A/C control unit
Threshold value	<ul style="list-style-type: none"> > 528k 	
Detecting time	<ul style="list-style-type: none"> 0.3 sec 	
FAIL SAFE	<ul style="list-style-type: none"> Control with the value of 25°C(77°F) 	

SPECIFICATION E1AB1CCB

Refer to DTC B1233.

MONITOR SCANTOOL DATA E60EDB2F

1. Connect scantool to data link connector(DLC).
2. Engine "ON"
3. Monitor the "INCAR TEMP. SENSOR" Parameter on the Scantool.

BLOWER AND A/C CONTROLS (AUTOMATIC)

HA -67

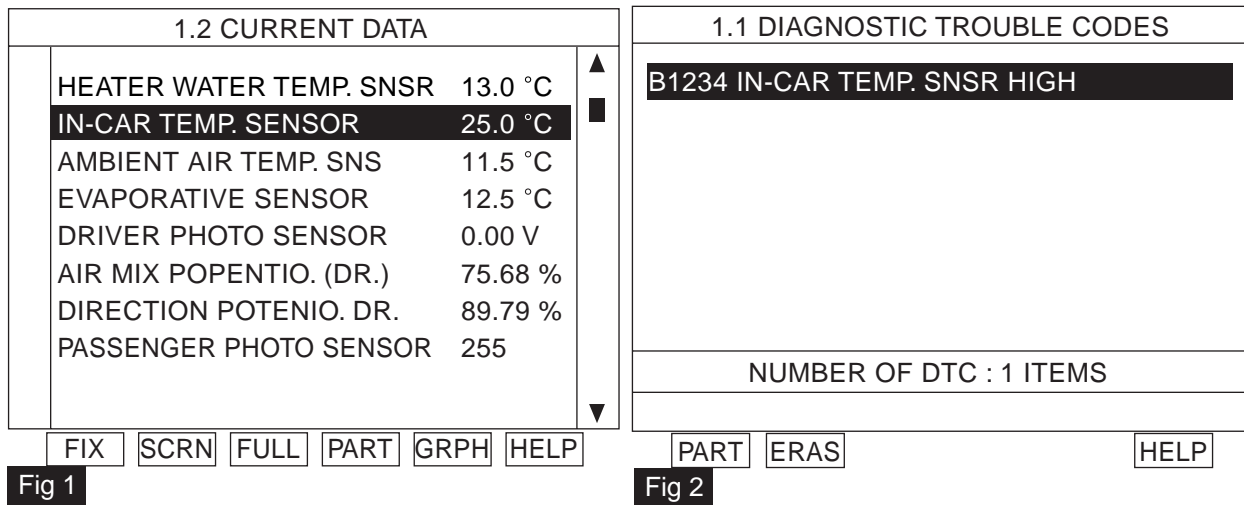

Fig 1 : The current data in abnormal state.
 Fig 2 : DTC B1234.

EQRE515A

4. Are the DTC B1234 present and is parameter of "INCAR TEMP. SENSOR" fixed?
 Parameter of "INCAR TEMP. SENSOR" will be fixed at 25 (77 °F), if there is any fault in INCAR TEMP. SENSOR.

YES

Go to "Inspection" procedure.

NO

Fault is intermittent caused by poor contact in the sensor's and/or A/C controller's connector or was repaired and A/C controller memory was not cleared. Thoroughly check connectors for looseness, poor connection, bending, corrosion, contamination, deterioration, or damage. Repair or replace as necessary and then go to "Verification of Vehicle Repair" procedure.

TERMINAL AND CONNECTOR INSPECTION E941866C

Refer to DTC B1233.

SIGNAL CIRCUIT INSPECTION E1781154

1. Check for short in harness.
 - 1) Ignition "OFF"
 - 2) Disconnect incar temp. sensor.
 - 3) Measure resistance between terminal "3" of incar temp. sensor and terminal "4" of A/C Control Unit.

Specification : Approx. 0

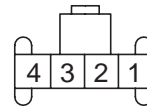
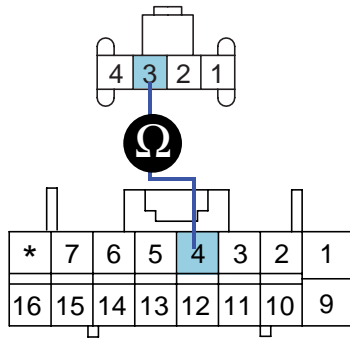

1. Sensor ground
2. Motor (-)
3. In-car sensor signal
4. Motor (+)

SGHHA6220L

4) Is the measured resistance within specifications?

YES

Go to "Ground circuit Inspection " procedure.

NO

Check for open in harness. Repair as necessary and go to "Verification of Vehicle Repair" procedure.

GROUND CIRCUIT INSPECTION EF779270

1. Check for open in ground harness.

- 1) Ignition "OFF" اولین سامانه دیجیتال تعمیرکاران
- 2) Disconnect incar temp. sensor.
- 3) Measure resistance between terminal "1" of incar temp. sensor and terminal "4" of A/C Control Unit.

Specification : Approx. 0

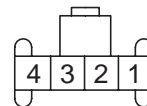
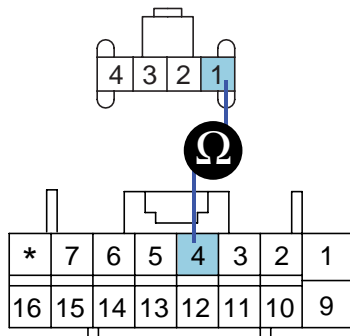

1. Sensor ground
2. Motor (-)
3. In-car sensor signal
4. Motor (+)

SGHHA6608L

BLOWER AND A/C CONTROLS (AUTOMATIC)

HA -69

4) Is the measured resistance within specifications?

YES

Go to "Component Inspection " procedure.

NO

Check for open in ground harness. Repair as necessary and go to "Verification of Vehicle Repair" procedure.

COMPONENT INSPECTION EB9720FD

Refer to DTC B1233.

VERIFICATION OF VEHICLE REPAIR E10F3C2D

Refer to DTC B1233.

دیجیتال خودرو

شرکت دیجیتال خودرو سامانه (مسئولیت محدود)

اولین سامانه دیجیتال تعمیرکاران خودرو در ایران



HA -70

HEATING, VENTILATION AND AIR CONDITIONING

DTC B1237 AMBIENT TEMPERATURE SENSOR SHORT (LOW)

COMPONENT LOCATION EBD78A29

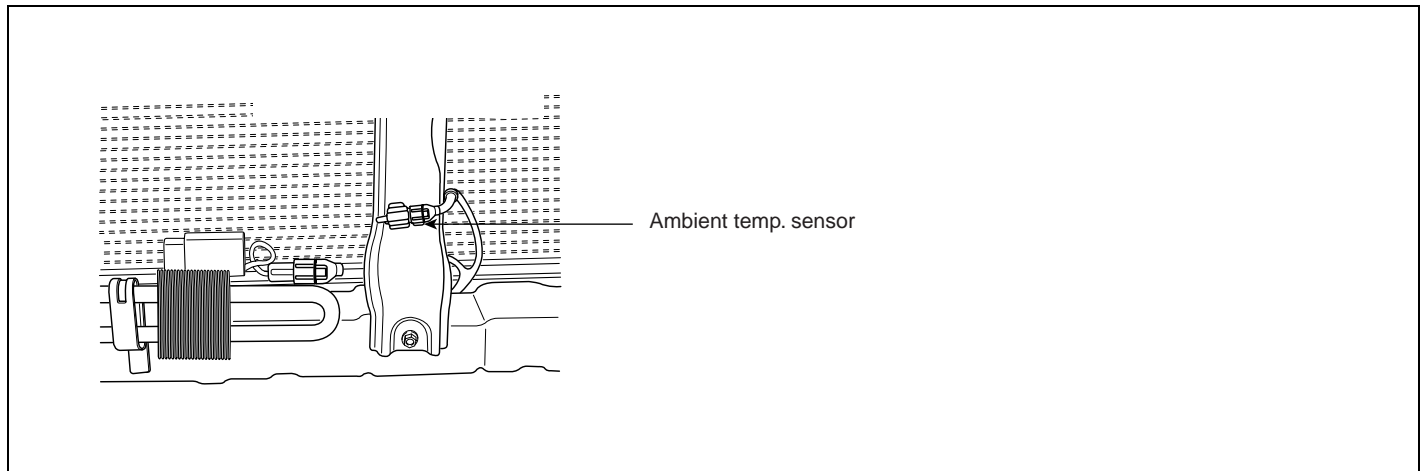

SGHHA6255L

GENERAL DESCRIPTION E2ABCF83

The ambient temperature sensor located at the center stay of the condenser, detects ambient air temperature. It is a negative type thermistor whose resistance is inversely proportional to temperature. Its output is used for discharge temperature sensor, sensor fail-safe, temperature regulation door lock, blower motor level control, mix mode control and in-car humidity control.

DTC DESCRIPTION EF007347

The A/C controller sets DTC B1237 if there is a short circuit in ambient temp. sensor signal harness or the measured resistance value of sensor is less than threshold value (about 7.48k)

DTC DETECTING CONDITION E76C2039

Item	Detecting Condition	Possible cause
DTC Strategy	<ul style="list-style-type: none"> Resistance check 	<ul style="list-style-type: none"> Short circuit in harness Faulty ambient temp. Sensor Faulty A/C control unit
Threshold value	<ul style="list-style-type: none"> < 7.48k 	
Detecting time	<ul style="list-style-type: none"> 0.3 sec 	
FAIL SAFE	<ul style="list-style-type: none"> Control with the value of 20°C(68°F) 	

SPECIFICATION EA51C1AC

Temperature[°C(°F)]	Resistance(k)	Temperature[°C(°F)]	Resistance(k)
-20 (-4)	271.46	20 (68)	37.313
-10 (14)	158.23	30 (86)	24.261
0 (32)	95.096	40 (104)	16.132
10 (50)	58.794	50 (122)	10.952

BLOWER AND A/C CONTROLS (AUTOMATIC)

HA -71

MONITOR SCANTOOL DATA E30FCFE7

1. Connect scantool to data link connector(DLC).
2. Engine "ON"
3. Monitor the "AMBIENT TEMP. SENSOR" Parameter on the Scantool.
Parameter of "AMBIENT TEMP. SENSOR" will be fixed at 20°C, if there is any fault in AMBIENT TEMP. SENSOR.

1.2 CURRENT DATA	
HEATER WATER TEMP. SNSR	17.0 °C
IN-CAR TEMP. SENSOR	12.0 °C
AMBIENT AIR TEMP. SNS	20.0 °C
EVAPORATIVE SENSOR	13.0 °C
DRIVER PHOTO SENSOR	0.00 V
AIR MIX POPENATIO. (DR.)	91.75 %
DIRECTION POTENIO. DR.	90.18 %
PASSENGER PHOTO SENSOR	255

1.1 DIAGNOSTIC TROUBLE CODES	
B1237 AMBIENT TEMP. SNSR LOW	
NUMBER OF DTC : 1 ITEMS	

Fig 1

Fig 1 : The current data in abnormal state.

Fig 2

Fig 2 : DTC B1237.

4. Are the DTC B1237 present and is parameter of "AMBIENT TEMP. SENSOR" fixed?

YES

Go to "Inspection" procedure.

NO

Fault is intermittent caused by poor contact in the sensor's and/or A/C controller's connector or was repaired and A/C controller memory was not cleared. Thoroughly check connectors for looseness, poor connection, bending, corrosion, contamination, deterioration, or damage. Repair or replace as necessary and then go to "Verification of Vehicle Repair" procedure.

TERMINAL AND CONNECTOR INSPECTION E20274CA

1. Many malfunctions in the electrical system are caused by poor harness and terminals.
Faults can also be caused by interference from other electrical systems, and mechanical or chemical damage.
2. Thoroughly check connectors for looseness, poor connection, bending, corrosion, contamination, deterioration, or damage.
3. Has a problem been found?

YES

Repair as necessary and go to "Verification of Vehicle Repair" procedure.

HA -72

HEATING, VENTILATION AND AIR CONDITIONING

NO

Go to "Signal circuit inspection" procedure.

SIGNAL CIRCUIT INSPECTION EC50D358

1. Check for short to ground in harness.
 - 1) Ignition "OFF"
 - 2) Disconnect ambient temp. sensor.
 - 3) Measure resistance between terminal "2" of ambient temp. sensor and chassis ground.

Specification : Approx.

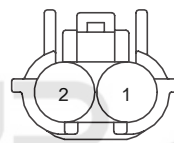
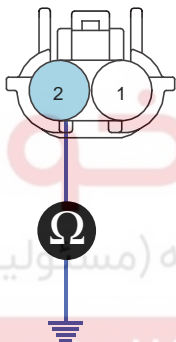

1. Ambient temp. sensor ground
2. Ambient temp. sensor signal(+)

SGHHA6221L

- 4) Is the measured resistance within specifications?

YES

Go to "Component Inspection" procedure.

NO

Check for short to ground in harness. Repair as necessary and go to "Verification of Vehicle Repair" procedure.

COMPONENT INSPECTION E3B39A1B

1. Check Ambient temp. sensor.
 - 1) Ignition "OFF"
 - 2) Disconnect ambient temp. sensor.
 - 3) Measure resistance between terminal "1" and "2" of ambient temp. sensor.

Specification : Refer the specifications in fig 3.

BLOWER AND A/C CONTROLS (AUTOMATIC)

HA -73

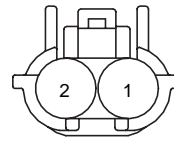
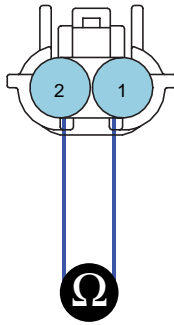

- 1, Ambient temp. sensor ground
2, Ambient temp. sensor signal(+)

SGHHA6222L

Temperature[°C(°F)]	Resistance(k)	Temperature[°C(°F)]	Resistance(k)
-20 (-4)	271.46	20 (68)	37.313
-10 (14)	158.23	30 (86)	24.261
0 (32)	95.096	40 (104)	16.132
10 (50)	58.794	50 (122)	10.952

4) Is the measured resistance within specifications in fig3? (tolerance limits $\pm 3\%$)

YES

شرکت دیجیتال خودرو (مسئولیت محدود)
Go to "Check A/C Control Unit" procedure.

اولین سامانه دیجیتال تعمیرکاران خودرو **NO** بیان

Substitute with a known-good ambient temp. sensor and check for proper operation.

If the problem is corrected, replace ambient temp. sensor and then go to "Verification of Vehicle Repair" procedure.

2. Check A/C Control Unit

- 1) Engine "ON"
- 2) Disconnect ambient temp. sensor.
- 3) Measure voltage between terminal "3" of A/C Control Unit and chassis ground.

Specification : Approx. 5V

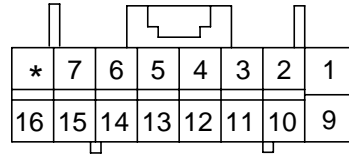
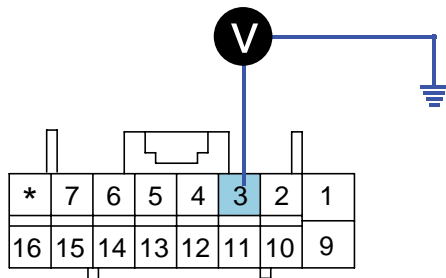

3. Ambient temp. sensor signal

SGHHA6223L

4) Is the measured voltage within specifications?

YES

Check connectors for looseness, poor connection, bending, corrosion, contamination, deterioration, or damage. Repair or replace as necessary and then go to "Verification of Vehicle Repair" procedure.

NO

Substitute with a known-good A/C Control Unit and check for proper operation.

If the problem is corrected, replace A/C Control Unit and then go to "Verification of Vehicle Repair" procedure.

VERIFICATION OF VEHICLE REPAIR EC81091E

After a repair, it is essential to verify that the fault has been corrected.

1. Connect scantool and select "Diagnostic Trouble Codes(DTCs)" mode and then clear DTC.
2. Operate the vehicle and monitor the DTC on the scantool.
3. Are any DTCs present?

YES

Go to the applicable troubleshooting procedure.

NO

System is performing to specification at this time.

BLOWER AND A/C CONTROLS (AUTOMATIC)

HA -75

DTC B1238 AMBIENT TEMPERATURE SENSOR OPEN (HIGH)

COMPONENT LOCATION EDF0A6B1

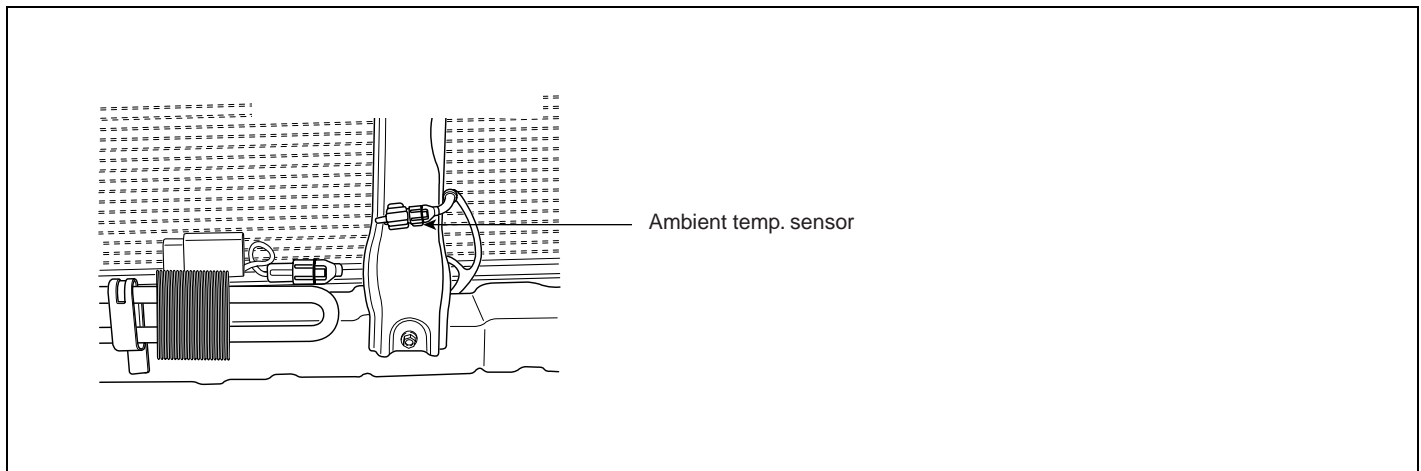

SGHHA6255L

GENERAL DESCRIPTION E4951473

Refer to DTC B1237.

DTC DESCRIPTION EBEAF741

The A/C controller sets DTC B1238 if there is an open circuit in ambient temp. sensor signal harness or the measured resistance value of sensor is more than threshold value (about 278k)

DTC DETECTING CONDITION ECC7468F

Item	Detecting Condition	Possible cause
DTC Strategy	<ul style="list-style-type: none"> Resistance check 	<ul style="list-style-type: none"> Open Circuit in harness Faulty ambient temp. Sensor Faulty A/C control unit
Threshold value	<ul style="list-style-type: none"> > 527k 	
Detecting time	<ul style="list-style-type: none"> 0.3 sec 	
FAIL SAFE	<ul style="list-style-type: none"> Control with the value of 20°C(67°F) 	

SPECIFICATION E611C585

Temperature[°C(°F)]	Resistance(k)	Temperature[°C(°F)]	Resistance(k)
-20 (-4)	271.46	20 (68)	37.313
-10 (14)	158.23	30 (86)	24.261
0 (32)	95.096	40 (104)	16.132
10 (50)	58.794	50 (122)	10.952

MONITOR SCANTOOL DATA E1C87A66

1. Connect scantool to Data Link Connector(DLC).
2. Engine "ON"

HA -76

HEATING, VENTILATION AND AIR CONDITIONING

3. Monitor the "AMBIENT TEMP. SENSOR" Parameter on the Scantool.
Parameter of "AMBIENT TEMP. SENSOR" will be fixed at 20 (67), if there is any fault in AMBIENT TEMP. SENSOR.

1.2 CURRENT DATA	
HEATER WATER TEMP. SNSR	17.0 °C
IN-CAR TEMP. SENSOR	12.0 °C
AMBIENT AIR TEMP. SNS	20.0 °C
EVAPORATIVE SENSOR	13.0 °C
DRIVER PHOTO SENSOR	0.00 V
AIR MIX POPENATIO. (DR.)	91.75 %
DIRECTION POTENIO. DR.	90.18 %
PASSENGER PHOTO SENSOR	255

FIX SCRN FULL PART GRPH HELP

Fig 1

Fig 1 : The current data in abnormal state.

1.1 DIAGNOSTIC TROUBLE CODES	
B1238 AMBIENT TEMP. SNSR HIGH	
NUMBER OF DTC : 1 ITEMS	

PART ERAS HELP

Fig 2

Fig 2 : DTC B1238.

4. Are the DTC B1238 present and is parameter of "AMBIENT TEMP. SENSOR" fixed?

YES

Go to "Inspection" procedure.

NO

Fault is intermittent caused by poor contact in the sensor's and/or A/C controller's connector or was repaired and A/C controller memory was not cleared. Thoroughly check connectors for looseness, poor connection, bending, corrosion, contamination, deterioration, or damage. Repair or replace as necessary and then go to "Verification of Vehicle Repair" procedure.

TERMINAL AND CONNECTOR INSPECTION E7F0FB77

- Many malfunctions in the electrical system are caused by poor harness and terminals. Faults can also be caused by interference from other electrical systems, and mechanical or chemical damage.
- Thoroughly check connectors for looseness, poor connection, bending, corrosion, contamination, deterioration, or damage.
- Has a problem been found?

YES

Repair as necessary and go to "Verification of Vehicle Repair" procedure.

NO

Go to "Signal circuit inspection" procedure.

BLOWER AND A/C CONTROLS (AUTOMATIC)

HA -77

SIGNAL CIRCUIT INSPECTION

E124C6B6

1. Check for open in harness.
 - 1) Ignition "OFF"
 - 2) Disconnect ambient temp. sensor.
 - 3) Measure resistance between terminal "2" of ambient temp. sensor and terminal "3" of A/C Control Unit.

 Specification : Approx. 0



SGHHA6224L

- 4) Is the measured resistance within specifications?

YES

Go to "Ground circuit Inspection " procedure.

NO

Check for open in harness. Repair as necessary and go to "Verification of Vehicle Repair" procedure.

GROUND CIRCUIT INSPECTION

EA9F4A89

1. Check for open in ground harness.
 - 1) Ignition "OFF"
 - 2) Disconnect ambient temp. sensor.
 - 3) Measure resistance between terminal "1" of ambient temp. sensor and chassis ground.

 Specification : Approx. 0

HA -78

HEATING, VENTILATION AND AIR CONDITIONING

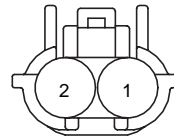
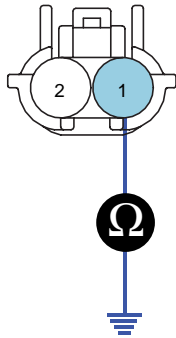

1. Ambient temp. sensor ground
2. Ambient temp. sensor signal(+)

SGHHA6225L

4) Is the measured resistance within specifications?

YES

Go to "Component Inspection " procedure.

NO

Check for open in ground harness. Repair as necessary and go to "Verification of Vehicle Repair" procedure.

COMPONENT INSPECTION E513CAB3

Refer to DTC B1237.

VERIFICATION OF VEHICLE REPAIR E58CEDF6

Refer to DTC B1237.

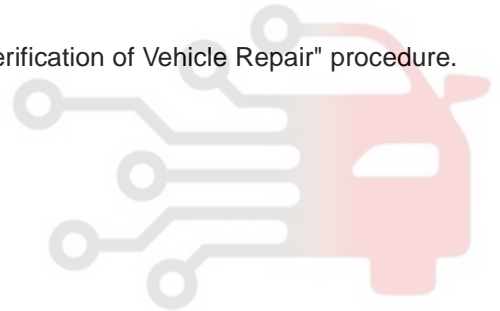

BLOWER AND A/C CONTROLS (AUTOMATIC)

HA -79

DTC B1241 EVAPORATOR TEMPERATURE SENSOR SHORT (LOW)

COMPONENT LOCATION EFE0E76C

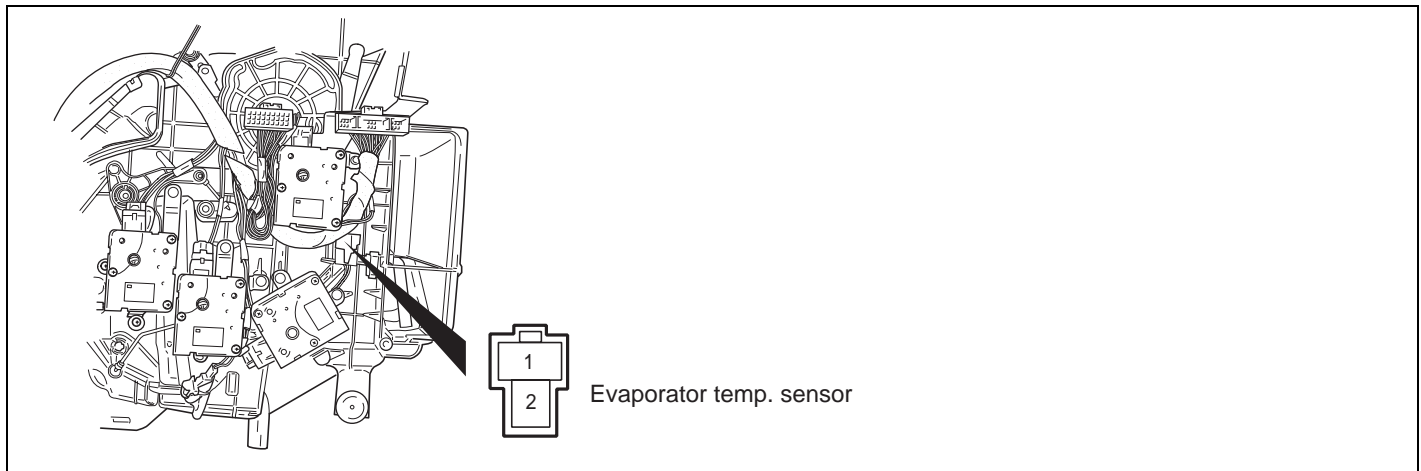

SGHHA6256L

GENERAL DESCRIPTION E8813265

The Evaporator temperature sensor located on heater unit, detects the core temperature and interrupts compressor relay power, in order to prevent evaporator freezing by excessive cooling. It is a negative type thermistor whose resistance is inversely proportional to temperature.

DTC DESCRIPTION E059C248

The A/C controller sets DTC B1241 if there is a short circuit in evaporator temp. sensor signal harness or the measured resistance value of sensor is less than threshold value (about 2.3k)

DTC DETECTING CONDITION E71F012F

Item	Detecting Condition	Possible cause
DTC Strategy	• Resistance check	<ul style="list-style-type: none"> • Short circuit in harness • Faulty Evaporator temp. Sensor • Faulty A/C control unit
Threshold value	• < 2.3k	
Detecting time	• 0.3 sec	
FAIL SAFE	• Control with the value of -2°C(28.4°F)	

SPECIFICATION E8C0ABD9

Resistance value of evaporator sensor as a function of temperature.

Temperature[°C(°F)]	Resistance(k)	Temperature[°C(°F)]	Resistance(k)
-20 (-4)	31.51	20 (68)	5.195
-10 (14)	19.27	30 (86)	3.525
0 (32)	12.12	40 (104)	2.443
10 (50)	7.836	50 (122)	1.727

HA -80

HEATING, VENTILATION AND AIR CONDITIONING

MONITOR SCANTOOL DATA E6823FFB

1. Connect scantool to Data Link Connector(DLC).
2. Engine "ON"
3. Monitor the "EVAPORATIVE SENSOR" Parameter on the Scantool.

1.2 CURRENT DATA		1.1 DIAGNOSTIC TROUBLE CODES	
HEATER WATER TEMP. SNSR	13.0 °C	B1241 EVAP. SENSOR - LOW INPUT	
IN-CAR TEMP. SENSOR	12.0 °C		
AMBIENT AIR TEMP. SNS	12.0 °C		
EVAPORATIVE SENSOR	-2.0 °C		
DRIVER PHOTO SENSOR	0.00 V		
AIR MIX POPENATIO. (DR.)	91.75 %		
DIRECTION POTENIO. DR.	90.18 %		
PASSENGER PHOTO SENSOR	255		
		NUMBER OF DTC : 1 ITEMS	

FIX SCRN FULL PART GRPH HELP
PART ERAS HELP

Fig 1

Fig 1 : The current data in abnormal state.

Fig 2

Fig 2 : DTC B1241.

4. Are the DTC B1241 present and is parameter of "EVAPORATIVE SENSOR" fixed?
Parameter of "EVAPORATIVE SENSOR" will be fixed at -2 (28.4), if there is any fault in EVAPORATIVE SENSOR.

YES

Go to "Inspection" procedure.

NO

Fault is intermittent caused by poor contact in the sensor's and/or A/C controller's connector or was repaired and A/C controller memory was not cleared. Thoroughly check connectors for looseness, poor connection, bending, corrosion, contamination, deterioration, or damage. Repair or replace as necessary and then go to "Verification of Vehicle Repair" procedure.

TERMINAL AND CONNECTOR INSPECTION EAF84DC8

1. Many malfunctions in the electrical system are caused by poor harness and terminals. Faults can also be caused by interference from other electrical systems, and mechanical or chemical damage.
2. Thoroughly check connectors for looseness, poor connection, bending, corrosion, contamination, deterioration, or damage.
3. Has a problem been found?

YES

Repair as necessary and go to "Verification of Vehicle Repair" procedure.

BLOWER AND A/C CONTROLS (AUTOMATIC)

HA -81

NO

Go to "Signal circuit inspection" procedure.

SIGNAL CIRCUIT INSPECTION EAF42A6E

1. Check for short to ground in harness.

- 1) Ignition "OFF"
- 2) Disconnect evaporator temp. sensor.
- 3) Measure resistance between terminal "2" of evaporator temp. sensor and chassis ground.

Specification : Approx.



SGHHA6226L

4) Is the measured resistance within specifications?

YES

Go to "Component Inspection" procedure.

NO

Check for short to ground in harness. Repair as necessary and go to "Verification of Vehicle Repair" procedure.

COMPONENT INSPECTION EB45B875

1. Check evaporator temp. sensor.

- 1) Ignition "OFF"
- 2) Disconnect evaporator temp. sensor.
- 3) Measure resistance between terminal "1" and "2" of evaporator temp. sensor.

Specification : Refer the specifications in fig 3.

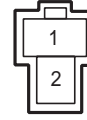
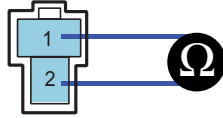

1. Evaporator temp. sensor ground
2. Evaporator temp. sensor signal

SGHHA6227L

Temperature[°C(°F)]	Resistance(k)	Temperature[°C(°F)]	Resistance(k)
-20 (-4)	31.51	20 (68)	5.195
-10 (14)	19.27	30 (86)	3.525
0 (32)	12.12	40 (104)	2.443
10 (50)	7.836	50 (122)	1.727

- 4) Is the measured resistance within specifications in fig3? (tolerance limits $\pm 3\%$)

YES

شرکت دیجیتال خودرو (مسئولیت محدود)
Go to "Check A/C Control Unit" procedure.

اولین سامانه دیجیتال تعمیرکاران خودرو **NO** ران

Substitute with a known-good evaporator temp. sensor and check for proper operation.

If the problem is corrected, replace evaporator temp. sensor and then go to "Verification of Vehicle Repair" procedure.

2. Check A/C Control Unit

- 1) Engine "ON"
- 2) Disconnect evaporator temp. sensor.
- 3) Measure voltage between terminal "2" of A/C Control Unit and chassis ground.

Specification : Approx. 5V

BLOWER AND A/C CONTROLS (AUTOMATIC)

HA -83

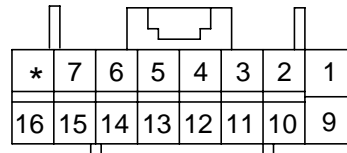
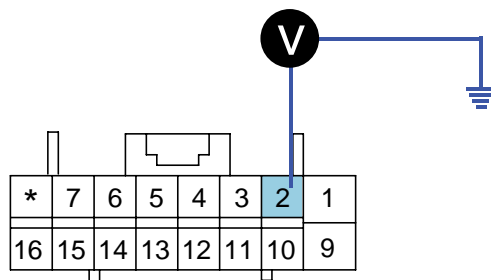

2. Evaporator temp. sensor signal

SGHHA6228L

4) Is the measured voltage within specifications?

YES

Check connectors for looseness, poor connection, bending, corrosion, contamination, deterioration, or damage. Repair or replace as necessary and then go to "Verification of Vehicle Repair" procedure.

NO

Substitute with a known-good A/C Control Unit and check for proper operation.

If the problem is corrected, replace A/C Control Unit and then go to "Verification of Vehicle Repair" procedure.

VERIFICATION OF VEHICLE REPAIR E32624E3

After a repair, it is essential to verify that the fault has been corrected.

1. Connect scantool and select "Diagnostic Trouble Codes(DTCs)" mode and then clear DTC.
2. Operate the vehicle and monitor the DTC on the scantool.
3. Are any DTCs present?

YES

Go to the applicable troubleshooting procedure.

NO

System is performing to specification at this time.

HA -84

HEATING, VENTILATION AND AIR CONDITIONING

DTC B1242 EVAPORATOR TEMPERATURE SENSOR OPEN (HIGH)

COMPONENT LOCATION E1D80ABD

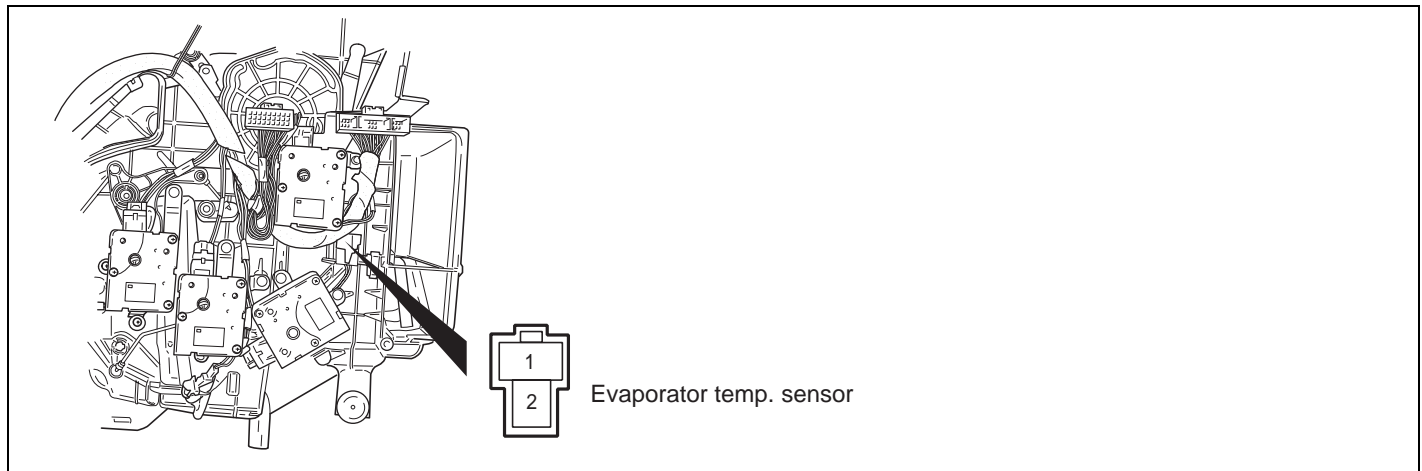

SGHHA6256L

GENERAL DESCRIPTION E073E679

Refer to DTC B1241.

DTC DESCRIPTION E9354B2A

The A/C controller sets DTC B1242 if there is an open circuit in evaporator temp. sensor signal harness or the measured resistance value of sensor is more than threshold value (about 19.7k)

DTC DETECTING CONDITION E61B9B78

Item	Detecting Condition	Possible cause
DTC Strategy	<ul style="list-style-type: none"> Resistance check 	<ul style="list-style-type: none"> Open Circuit in harness Faulty Evaporator temp. Sensor Faulty A/C control unit
Threshold value	<ul style="list-style-type: none"> > 19.7k 	
Detecting time	<ul style="list-style-type: none"> 0.3 sec 	
FAIL SAFE	<ul style="list-style-type: none"> Control with the value of -2°C(28.4°F) 	

SPECIFICATION E70F7716

Refer to DTC B1241.

MONITOR SCANTOOL DATA E1C7971C

1. Connect scantool to Data Link Connector(DLC).
2. Engine "ON"
3. Monitor the "EVAPORATIVE SENSOR" Parameter on the Scantool.

BLOWER AND A/C CONTROLS (AUTOMATIC)

HA -85

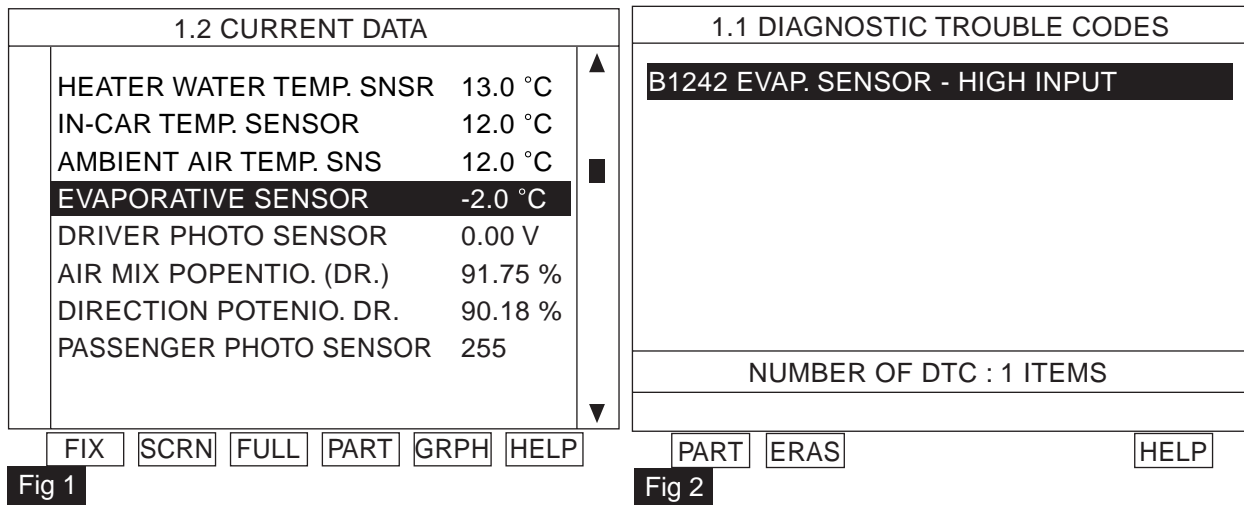

Fig 1 : The current data in abnormal state.
Fig 2 : DTC B1242.

LQIE520A

4. Are the DTC B1242 present and is parameter of "EVAPORATIVE SENSOR" fixed?
Parameter of "EVAPORATIVE SENSOR" will be fixed at -2 (28.4), if there is any fault in EVAPORATIVE SENSOR.

YES

Go to "Inspection" procedure.

NO

Fault is intermittent caused by poor contact in the sensor's and/or A/C controller's connector or was repaired and A/C controller memory was not cleared. Thoroughly check connectors for looseness, poor connection, bending, corrosion, contamination, deterioration, or damage. Repair or replace as necessary and then go to "Verification of Vehicle Repair" procedure.

TERMINAL AND CONNECTOR INSPECTION E2790250

Refer to DTC B1241.

SIGNAL CIRCUIT INSPECTION EE8145E7

1. Check for open in harness.
 - 1) Ignition "OFF"
 - 2) Disconnect evaporator temp. sensor.
 - 3) Measure resistance between terminal "2" of evaporator temp. sensor and terminal "2" of A/C Control Unit.

Specification : Approx. 0

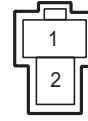
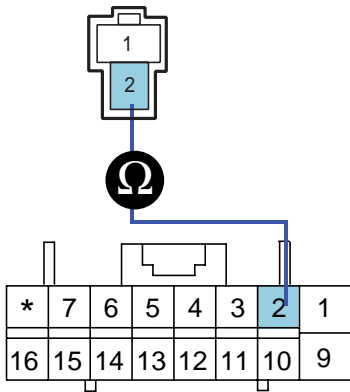

- 1. Evaporator temp. sensor ground
- 2. Evaporator temp. sensor signal

SGHHA6229L

4) Is the measured resistance within specifications?

YES

Go to "Ground circuit Inspection " procedure.

NO

Check for open in harness. Repair as necessary and go to "Verification of Vehicle Repair" procedure.

GROUND CIRCUIT INSPECTION ED7ACE72

1. Check for open in ground harness.

- 1) اولين سامانه ديگيټال تعميركاران Ignition "OFF"
- 2) Disconnect evaporator temp. sensor.
- 3) Measure resistance between terminal "1" of evaporator temp. sensor and chassis ground.

Specification : Approx. 0

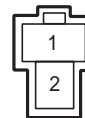
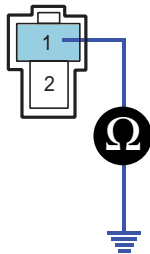

- 1. Evaporator temp. sensor ground
- 2. Evaporator temp. sensor signal

SGHHA6230L

BLOWER AND A/C CONTROLS (AUTOMATIC)

HA -87

4) Is the measured resistance within specifications?

YES

Go to "Component Inspection " procedure.

NO

Check for open in harness. Repair as necessary and go to "Verification of Vehicle Repair" procedure.

COMPONENT INSPECTION EAB63ADA

Refer to DTC B1241.

VERIFICATION OF VEHICLE REPAIR E70127E7

Refer to DTC B1241.

دیجیتال خودرو

شرکت دیجیتال خودرو سامانه (مسئولیت محدود)

اولین سامانه دیجیتال تعمیرکاران خودرو در ایران



HA -88

HEATING, VENTILATION AND AIR CONDITIONING

DTC B1245 AIR MIX POTENTIOMETER OPEN (LOW) - DRIVER

COMPONENT LOCATION EFBA062E

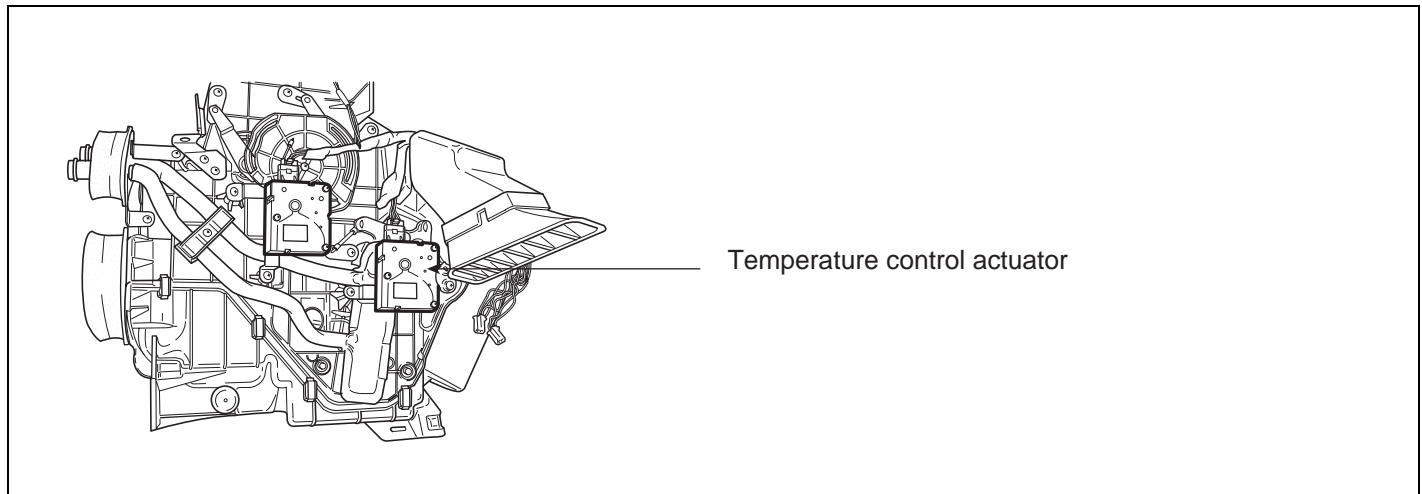

SGHHA6257L

GENERAL DESCRIPTION EA93BB84

Temperature control actuator located at heater unit, regulates the temperature by the procedure as follows. Signal from control unit adjusts position of temp. door by operating temp. motor and then temperature will be regulated by the hot/cold air ratio decided by position of temp. door.

DTC DESCRIPTION E26F4722

The A/C controller sets DTC B1245 if there is an open circuit or poor connection in the air mix potentiometer.

DTC DETECTING CONDITION E21A2812

Item	Detecting Condition	Possible cause
DTC Strategy	<ul style="list-style-type: none"> Voltage check 	<ul style="list-style-type: none"> Poor connection of connected part Open circuit in harness Short circuit in harness Faulty driver Air Mix potentiometer
Threshold value	<ul style="list-style-type: none"> < 0.1V 	
Detecting time	<ul style="list-style-type: none"> 0.3 sec 	
FAIL SAFE	<ul style="list-style-type: none"> If temperature setting 17~24.5°C(63~76°F) fix at max. cooling position. If temperature setting 25~32°C(77~90°F) fix at max. heating position. 	

BLOWER AND A/C CONTROLS (AUTOMATIC)

HA -89

SPECIFICATION E7068E49

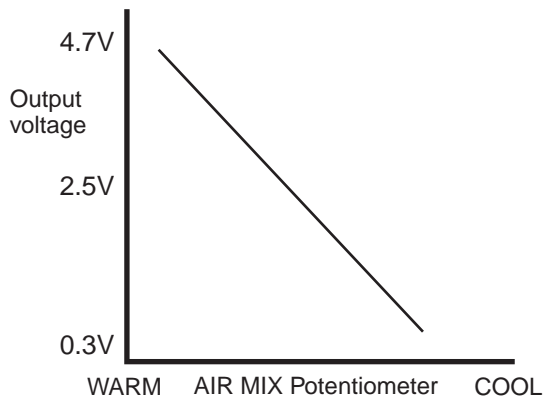

LQIE521B

MONITOR SCANTOOL DATA E0F8FBE9

1. Connect scantool to Data Link Connector(DLC).
2. Engine "ON"
3. Monitor the "Driver Air Mix Potentiometer" Parameter on the Scantool while operating temp. switch.

1.2 CURRENT DATA	
HEATER WATER TEMP.SNSR	13.0 °C
IN-CAR TEMP.SENSOR	12.0 °C
AMBIENT AIR TEMP.SNS	12.0 °C
EVAPORATIVE SENSOR	12.5 °C
DRIVER PHOTO SENSOR	0.00 V
AIR MIX POPENATIO.(DR.)	5.9 %
DIRECTION POTENIO.DR.	90.18 %
PASSENGER PHOTO SENSOR	255

Fig 1

Fig 1 : The current data in abnormal state.

1.1 DIAGNOSTIC TROUBLE CODES	
B1245 AIR MIX P. - LOW INPUT	
NUMBER OF DTC : 1 ITEMS	

Fig 2

Fig 2 : DTC B1245.

LQIE521C

4. Are the DTC B1245 present and is parameter of "Driver Air Mix Potentiometer" fixed?
Parameter of "Driver Air Mix Potentiometer" will be fixed at 100%(or any value above 90%), or 0% (or any value below 10%), if there is any fault in Driver Air Mix potentiometer.

YES

Go to "Inspection" procedure.

HA -90

HEATING, VENTILATION AND AIR CONDITIONING

NO

Fault is intermittent caused by poor contact in the sensor's and/or A/C controller's connector or was repaired and A/C controller memory was not cleared. Thoroughly check connectors for looseness, poor connection, bending, corrosion, contamination, deterioration, or damage. Repair or replace as necessary and then go to "Verification of Vehicle Repair" procedure.

TERMINAL AND CONNECTOR INSPECTION EFF8A3F5

1. Many malfunctions in the electrical system are caused by poor harness and terminals. Faults can also be caused by interference from other electrical systems, and mechanical or chemical damage.
2. Thoroughly check connectors for looseness, poor connection, bending, corrosion, contamination, deterioration, or damage.
3. Has a problem been found?

YES

Repair as necessary and go to "Verification of Vehicle Repair" procedure.

NO

Go to "Signal circuit inspection" procedure.

SIGNAL CIRCUIT INSPECTION E37B4A7B

1. Check for open in harness.
 - 1) Ignition "OFF"
 - 2) Disconnect Driver Air Mix potentiometer.
 - 3) Measure resistance between terminal "5" of Driver Air Mix Potentiometer and terminal "2" of A/C control unit.

Specification : Approx. 0

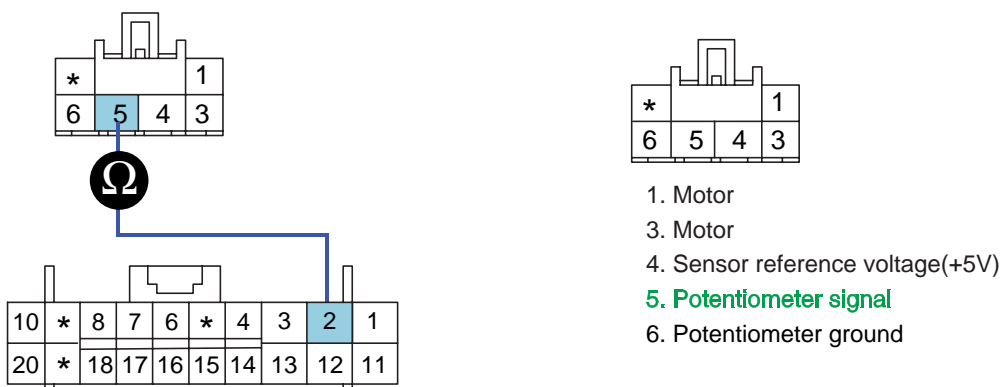

1. Motor
3. Motor
4. Sensor reference voltage(+5V)
5. Potentiometer signal
6. Potentiometer ground

SGHHA6231L

BLOWER AND A/C CONTROLS (AUTOMATIC)

HA -91

4) Is the measured resistance within specifications?

YES

Go to "Check for short to ground in harness" procedure.

NO

Check for open in signal harness. Repair as necessary and go to "Verification of Vehicle Repair" procedure.

2. Check for short to ground in harness.

- 1) Ignition "OFF"
- 2) Disconnect Driver Air Mix potentiometer.
- 3) Measure resistance between terminal "5" of Driver Air Mix Potentiometer and chassis ground.

Specification : Approx.

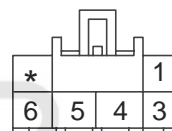
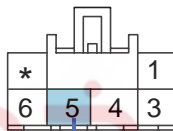

1. Motor
3. Motor
4. Sensor reference voltage(+5V)
5. Potentiometer signal
6. Potentiometer ground

SGHHA6232L

4) Is the measured resistance within specifications?

YES

Go to "Power circuit Inspection" procedure.

NO

Check for short to ground in signal harness. Repair as necessary and go to "Verification of Vehicle Repair" procedure.

POWER SUPPLY CIRCUIT INSPECTION E5B4D90A

1. Check for short or open in harness.

- 1) Ignition "ON"
- 2) Connect Driver Air Mix Potentiometer.
- 3) Measure voltage between terminal "4" of Driver Air Mix Potentiometer and chassis ground.

Specification : Approx. 5V

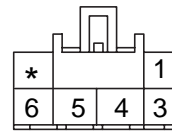
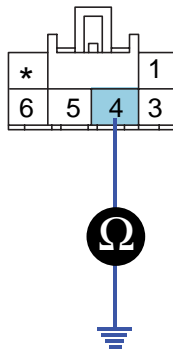

- 1. Motor
- 3. Motor
- 4. Sensor reference voltage(+5V)
- 5. Potentiometer signal
- 6. Potentiometer ground

SGHHA6233L

4) Is the measured voltage within specifications?

YES

Go to "Component inspection" procedure.

NO

Check for short or open in power harness. Repair as necessary and go to "Verification of Vehicle Repair" procedure.

COMPONENT INSPECTION EAB26D7C

1. Check actuator motor. اولین سامانه دیجیتال تعمیرکاران
 - 1) Ignition "OFF"
 - 2) Disconnect Driver Air Mix Potentiometer.
 - 3) Verify that the temperature actuator operates to the hot position when connecting 12V to the terminal "1" and grounding terminal "3".
 - 4) Verify that the temperature actuator operates to the cool position when the connections are reversed.

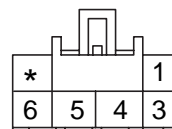
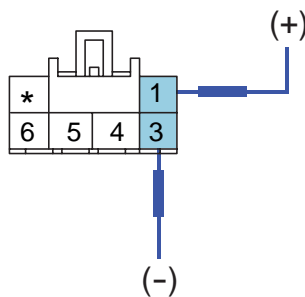

- 1. Motor
- 3. Motor
- 4. Sensor reference voltage(+5V)
- 5. Potentiometer signal
- 6. Potentiometer ground

SGHHA6212L

5) Does the actuator work properly?

BLOWER AND A/C CONTROLS (AUTOMATIC)**HA -93****YES**

Go to "Check potentiometer" procedure.

NO

Substitute with a known-good actuator and check for proper operation. If the problem is corrected, replace actuator and then go to "Verification of Vehicle Repair" procedure.

2. Check potentiometer

- 1) Ignition "ON"
- 2) Connect Driver Air Mix potentiometer.
- 3) Measure voltage between terminal "5" and "6" of Driver Air Mix potentiometer while operating the temp. switch.

Specification : Refer the specifications in fig 3)

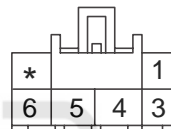
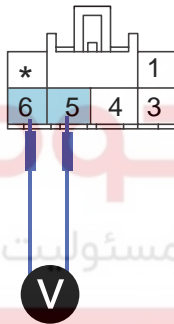

1. Motor
3. Motor
4. Sensor reference voltage(+5V)
5. Potentiometer signal
6. Potentiometer ground

SGHHA6213L

Door position	Voltage (5-6)	Error detecting
MAX. Cooling	$0.3 \pm 0.15V$	Low voltage : 0.08V or less
MAX. Heating	$4.7 \pm 0.15V$	High voltage : 4.9V or more

**Fig 3**

Fig 3) Specifications : Voltage value of air mix potentiometer as a function of position of setting temperature.

LQIE521J

4) Is the measured voltage within specifications in fig3?

YES

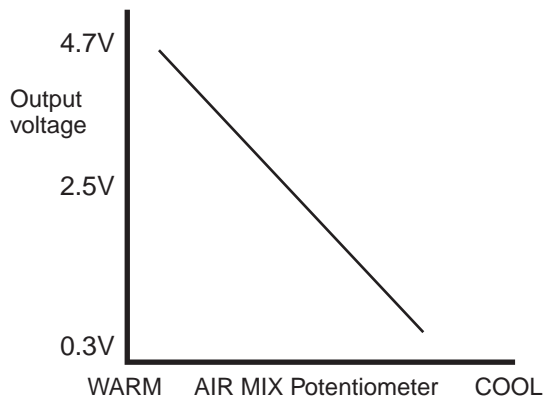
Check connectors for looseness, poor connection, bending, corrosion, contamination, deterioration, or damage. Repair or replace as necessary and then go to "Verification of Vehicle Repair" procedure.

NO

Substitute with a known-good actuator and check for proper operation. If the problem is corrected, replace actuator and then go to "Verification of Vehicle Repair" procedure.

VERIFICATION OF VEHICLE REPAIR

E3E12E94

After a repair, it is essential to verify that the fault has been corrected.

1. Connect scantool and select "Diagnostic Trouble Codes(DTCs)" mode and then clear DTC.
2. Operate the vehicle and monitor the DTC on the scantool.
3. Are any DTCs present?

YES

Go to the applicable troubleshooting procedure.

NO

System is performing to specification at this time.

BLOWER AND A/C CONTROLS (AUTOMATIC)

HA -95

DTC B1246 AIR MIX POTENTIOMETER SHORT (HIGH) - DRIVER

COMPONENT LOCATION EB8CF5

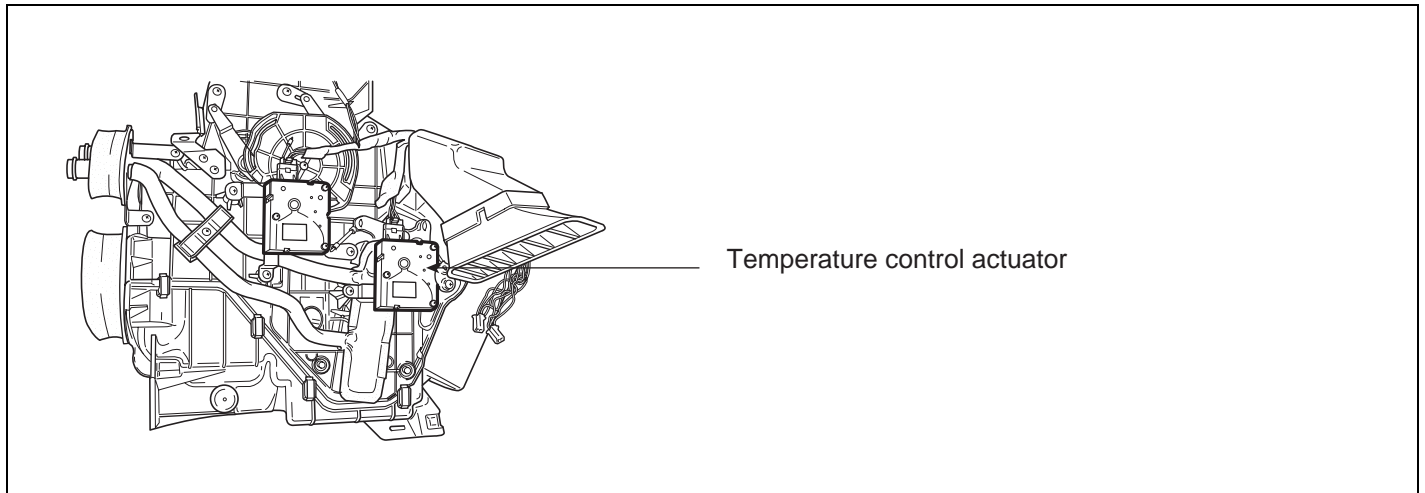

SGHHA6257L

GENERAL DESCRIPTION E8AF0D22

Refer to DTC B1245.

DTC DESCRIPTION E815CF4D

The A/C controller sets DTC B1246 if there is a short to power in the air mix potentiometer.

DTC DETECTING CONDITION E4E8952D

Item	Detecting Condition	Possible cause
DTC Strategy	<ul style="list-style-type: none"> Voltage check 	<ul style="list-style-type: none"> Short circuit in harness Faulty driver Air Mix potentiometer
Threshold value	<ul style="list-style-type: none"> > 4.9V 	
Detecting time	<ul style="list-style-type: none"> 0.3 sec 	
FAIL SAFE	<ul style="list-style-type: none"> If temperature setting 17~24.5°C(63~76°F) fix at max. cooling position. If temperature setting 25~32°C(77~90°F) fix at max. heating position. 	

SPECIFICATION E6C9EC3C

Refer to DTC B1245.

MONITOR SCANTOOL DATA EAC82AAF

1. Connect scantool to Data Link Connector(DLC).
2. Engine "ON"
3. Monitor the "Driver Air Mix Potentiometer" Parameter on the Scantool while operating temp. switch.

HA -96

HEATING, VENTILATION AND AIR CONDITIONING

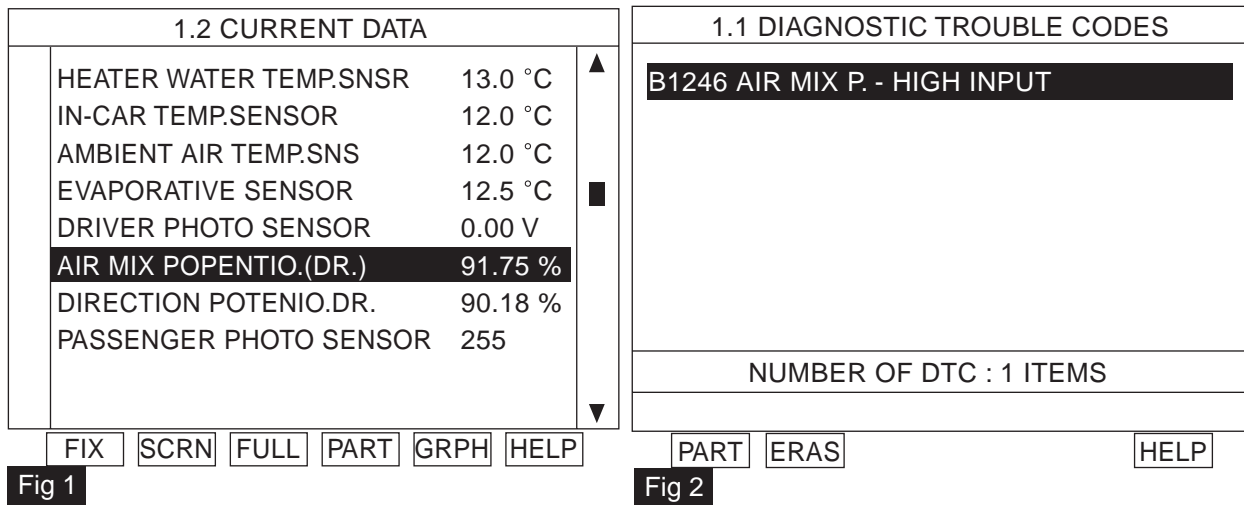

Fig 1 : The current data in abnormal state.

Fig 2 : DTC B1246.

LQIE522A

4. Are the DTC B1246 present and is parameter of "Driver Air Mix potentiometer" fixed?
Parameter of "Driver Air Mix potentiometer" will be fixed at 100%(or any value above 90%), or 0% (or any value below 10%), if there is any fault in Driver Air Mix potentiometer.

YES

Go to "Inspection" procedure.

NO

Fault is intermittent caused by poor contact in the sensor's and/or A/C controller's connector or was repaired and A/C controller memory was not cleared. Thoroughly check connectors for looseness, poor connection, bending, corrosion, contamination, deterioration, or damage. Repair or replace as necessary and then go to "Verification of Vehicle Repair" procedure.

TERMINAL AND CONNECTOR INSPECTION E78C9723

Refer to DTC B1245.

SIGNAL CIRCUIT INSPECTION EA4D52C0

- Check for short in harness.
 - Ignition "OFF"
 - Disconnect Driver Air Mix potentiometer.
 - Measure resistance between terminal "4" and "5" of Driver Air Mix potentiometer.

Specification : Approx.

BLOWER AND A/C CONTROLS (AUTOMATIC)

HA -97

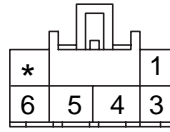
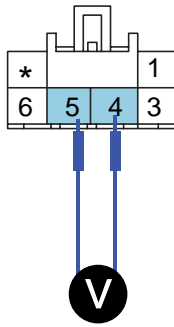

- 1. Motor
- 3. Motor
- 4. Sensor reference voltage(+5V)
- 5. Potentiometer signal
- 6. Potentiometer ground

SGHHA6214L

4) Is the measured resistance within specifications?

YES

Go to "Ground circuit Inspection" procedure.

NO

Check for short to power harness in signal harness. Repair as necessary and go to "Verification of Vehicle Repair" procedure.

GROUND CIRCUIT INSPECTION E022F725

1. Check for open in harness.
 - 1) Ignition "OFF"
 - 2) Disconnect Driver Air Mix Potentiometer.
 - 3) Measure resistance between terminal "5" of Driver Air Mix Potentiometer and chassis ground.

Specification : Approx. 0

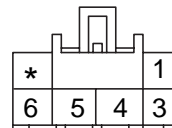
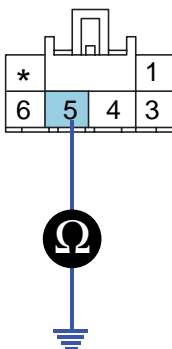

- 1. Motor
- 3. Motor
- 4. Sensor reference voltage(+5V)
- 5. Potentiometer signal
- 6. Potentiometer ground

SGHHA6232L

4) Is the measured resistance within specifications?

HA -98

HEATING, VENTILATION AND AIR CONDITIONING

YES

Go to "Component Inspection" procedure.

NO

Check for open in ground harness. Repair as necessary and go to "Verification of Vehicle Repair" procedure.

COMPONENT INSPECTION E5666BE0

1. Check actuator motor.

- 1) Ignition "OFF"
- 2) Disconnect Driver Air Mix Potentiometer.
- 3) Verify that the temperature actuator operates to the hot position when connecting 12V to the terminal "1" and grounding terminal "3".
- 4) Verify that the temperature actuator operates to the cool position when the connections are reversed.



SGHHA6212L

5) Does the actuator work properly?

YES

Go to "Check potentiometer" procedure.

NO

Substitute with a known-good actuator and check for proper operation. If the problem is corrected, replace actuator and then go to "Verification of Vehicle Repair" procedure.

2. Check potentiometer

- 1) Ignition "ON"
- 2) Connect Driver Air Mix potentiometer.
- 3) Measure voltage between terminal "5" and "6" of Driver Air Mix potentiometer while operating the temp. switch.

Specification : Refer the specifications in fig 3)

BLOWER AND A/C CONTROLS (AUTOMATIC)

HA -99

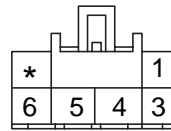
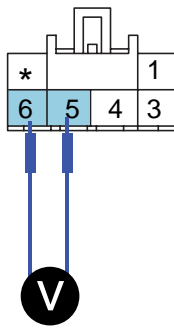

- 1. Motor
- 3. Motor
- 4. Sensor reference voltage(+5V)
- 5. Potentiometer signal
- 6. Potentiometer ground

SGHHA6213L

Door position	Voltage (5-6)	Error detecting
MAX. Cooling	0.3 ± 0.15V	Low voltage : 0.08V or less
MAX. Heating	4.7 ± 0.15V	High voltage : 4.9V or more



Fig 3

Fig 3) Specifications : Voltage value of air mix potentiometer as a function of position of setting temperature.

LQIE521J

4) Is the measured voltage within specifications in fig3?

YES

Check connectors for looseness, poor connection, bending, corrosion, contamination, deterioration, or damage. Repair or replace as necessary and then go to "Verification of Vehicle Repair" procedure.

NO

Substitute with a known-good actuator and check for proper operation. If the problem is corrected, replace actuator and then go to "Verification of Vehicle Repair" procedure.

VERIFICATION OF VEHICLE REPAIR EDCD9FEC

Refer to DTC B1245.

HA -100

HEATING, VENTILATION AND AIR CONDITIONING

DTC B1249 DIRECTION POTENTIOMETER OPEN (LOW) - DRIVER

COMPONENT LOCATION E9419EC5

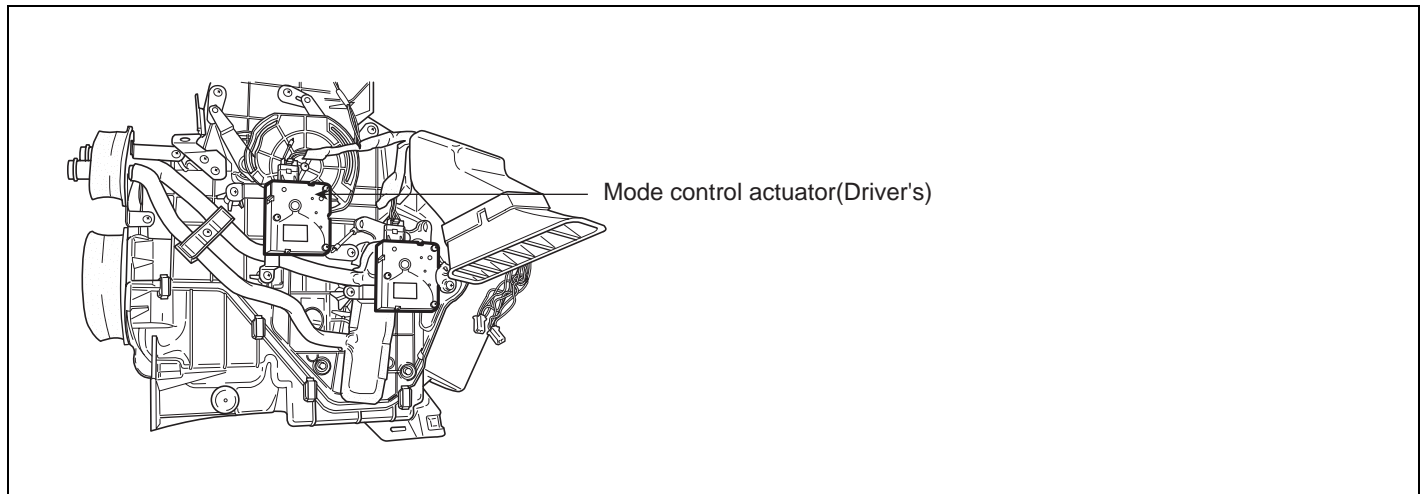

SGHHA6264L

GENERAL DESCRIPTION EBA97B29

The mode control actuator mounted on heater unit, adjusts position of mode door by operating Direction Motor based on signal of A/C control unit. Pressing mode select switch makes the mode control actuator shift in order of vent B/L floor mix.

DTC DESCRIPTION E665403D

The A/C controller sets DTC B1249 if there is an open circuit or poor connection in the Direction potentiometer.

DTC DETECTING CONDITION ED02A698

Item	Detecting Condition	Possible cause
DTC Strategy	<ul style="list-style-type: none"> Voltage check 	<ul style="list-style-type: none"> Poor connection of connected part Open circuit in harness Short circuit in harness Faulty driver direction potentiometer
Threshold value	<ul style="list-style-type: none"> < 0.1V 	
Detecting time	<ul style="list-style-type: none"> 0.3 sec 	
FAIL SAFE	<ul style="list-style-type: none"> Fix vent position, while selecting vent mode. Fix defrost position while selecting except vent mode. 	

BLOWER AND A/C CONTROLS (AUTOMATIC)

HA -101

SPECIFICATION E46CED05

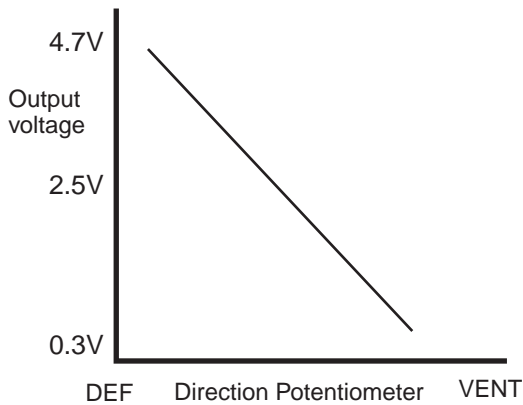

LQIE523B

MONITOR SCANTOOL DATA E1AB2666

1. Connect scantool to Data Link Connector(DLC).
2. Engine "ON"
3. Monitor the "DR. DIRECTION POTENTIO." parameter on the scantool while operating mode switch.

1.2 CURRENT DATA	
HEATER WATER TEMP.SNSR	13.0 °C
IN-CAR TEMP.SENSOR	11.5 °C
AMBIENT AIR TEMP.SNS	12.0 °C
EVAPORATIVE SENSOR	13.0 °C
DRIVER PHOTO SENSOR	0.00 V
AIR MIX POPENATIO.(DR.)	92.54 %
DIRECTION POTENIO.DR.	1.96 %
PASSENGER PHOTO SENSOR	255

Fig 1

Fig 1 : The current data in abnormal state.

1.1 DIAGNOSTIC TROUBLE CODES	
B1249 DIRECTION P. - LOW INPUT	
NUMBER OF DTC : 1 ITEMS	

Fig 2

Fig 2 : DTC B1249.

LQIE523C

4. Are the DTC B1249 present and is parameter of "DR. DIRECTION POTENTIO." fixed?
Parameter of "DR. DIRECTION POTENTIO." will be fixed at 100%(or any value above 90%), or 0% (or any value below 10%), if there is any fault in Driver Direction potentiometer.

YES

Go to "Inspection" procedure.

HA -102

HEATING, VENTILATION AND AIR CONDITIONING

NO

Fault is intermittent caused by poor contact in the sensor's and/or A/C controller's connector or was repaired and A/C controller memory was not cleared. Thoroughly check connectors for looseness, poor connection, bending, corrosion, contamination, deterioration, or damage. Repair or replace as necessary and then go to "Verification of Vehicle Repair" procedure.

TERMINAL AND CONNECTOR INSPECTION E4B45DB9

1. Many malfunctions in the electrical system are caused by poor harness and terminals. Faults can also be caused by interference from other electrical systems, and mechanical or chemical damage.
2. Thoroughly check connectors for looseness, poor connection, bending, corrosion, contamination, deterioration, or damage.
3. Has a problem been found?

YES

Repair as necessary and go to "Verification of Vehicle Repair" procedure.

NO

Go to "Signal circuit inspection" procedure.

SIGNAL CIRCUIT INSPECTION EF152E8E

1. Check for open in harness.
 - 1) Ignition "OFF"
 - 2) Disconnect Driver mode Actuator.
 - 3) Measure resistance between terminal "5" of Driver Direction potentiometer and terminal "1" of A/C control unit.

Specification : Approx. 0

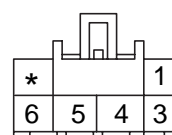
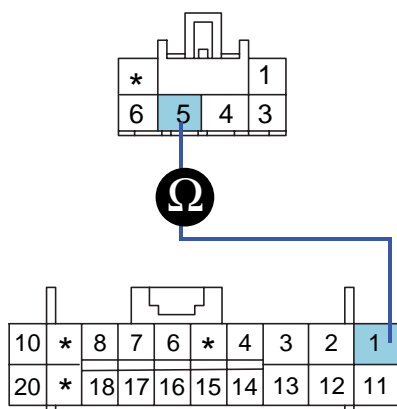

- 1. Motor
- 3. Motor
- 4. Sensor reference voltage(+5V)
- 5. Potentiometer signal
- 6. Potentiometer ground

SGHHA6235L

BLOWER AND A/C CONTROLS (AUTOMATIC)

HA -103

4) Is the measured resistance within specifications?

YES

Go to "Check for short to ground in harness" procedure.

NO

Check for open in signal harness. Repair as necessary and go to "Verification of Vehicle Repair" procedure.

2. Check for short to ground in harness.

- 1) Ignition "OFF"
- 2) Disconnect Driver mode Actuator.
- 3) Measure resistance between terminal "5" of Driver Direction potentiometer and chassis ground.

Specification : Approx.

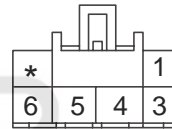
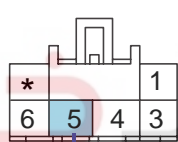

1. Motor
3. Motor
4. Sensor reference voltage(+5V)
5. Potentiometer signal
6. Potentiometer ground

SGHHA6210L

4) Is the measured resistance within specifications?

YES

Go to "Power circuit Inspection" procedure.

NO

Check for short to ground in signal harness. Repair as necessary and go to "Verification of Vehicle Repair" procedure.

POWER SUPPLY CIRCUIT INSPECTION EE002C9D

1. Check for short or open in harness.

- 1) Ignition "ON"
- 2) Connect Driver Direction potentiometer.
- 3) Measure voltage between terminal "4" of Driver Direction potentiometer and chassis ground.

Specification : Approx. 5V

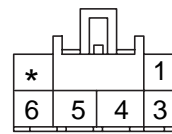
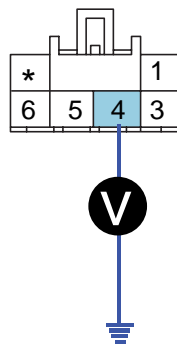

- 1. Motor
- 3. Motor
- 4. Sensor reference voltage(+5V)
- 5. Potentiometer signal
- 6. Potentiometer ground

SGHHA6236L

4) Is the measured voltage within specifications?

YES

Go to "Component Inspection" procedure.

NO

Check for short or open in power harness. Repair as necessary and go to "Verification of Vehicle Repair" procedure.

COMPONENT INSPECTION EE2575B1

1. Check actuator. اولین سامانه دیجیتال تعمیرکاران خود را

- 1) Ignition "OFF"
- 2) Disconnect Driver Direction potentiometer.
- 3) Verify that the mode actuator operates to the vent mode when connecting 12V to the terminal "1" and grounding terminal "3".
- 4) Verify that the mode actuator operates to the def mode when the connections are reversed.

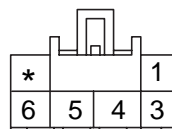
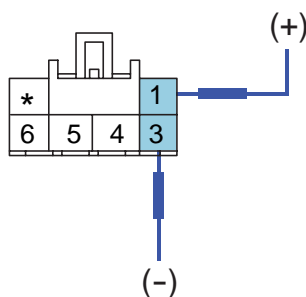

- 1. Motor
- 3. Motor
- 4. Sensor reference voltage(+5V)
- 5. Potentiometer signal
- 6. Potentiometer ground

SGHHA6212L

5) Does the actuator work properly?

BLOWER AND A/C CONTROLS (AUTOMATIC)

HA -105

YES

Go to "Check potentiometer" procedure.

NO

Substitute with a known-good actuator and check for proper operation. If the problem is corrected, replace actuator and then go to "Verification of Vehicle Repair" procedure.

2. Check potentiometer

- 1) Ignition "ON"
- 2) Connect Driver Direction potentiometer.
- 3) Measure voltage between terminal "5" and "6" of Driver Direction potentiometer as the mode switch is operated.

Specification : Refer the specifications in fig 3

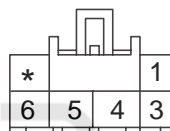
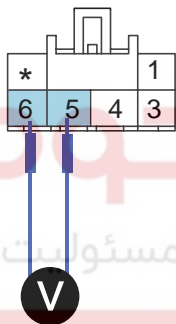

1. Motor
3. Motor
4. Sensor reference voltage(+5V)
5. Potentiometer signal
6. Potentiometer ground

SGHHA6213L

Door position	Voltage (5-6)	Error detecting
VENT	0.3 ± 0.15V	Under voltage : 0.08V or less Over voltage : 4.92V or more
BI-LEVEL(1)	1.35 ± 0.4V	
BI-LEVEL(2)	2.25 ± 0.4V	
FLOOR	3.0 ± 0.4V	
MIX	3.6 ± 0.4V	
DEF	4.7 ± 0.15V	

**Fig 3**

Fig 3) Specifications : Voltage value as a function of position of direction potentiometer.

LQIE523J

4) Is the measured voltage within specifications in fig3?

YES

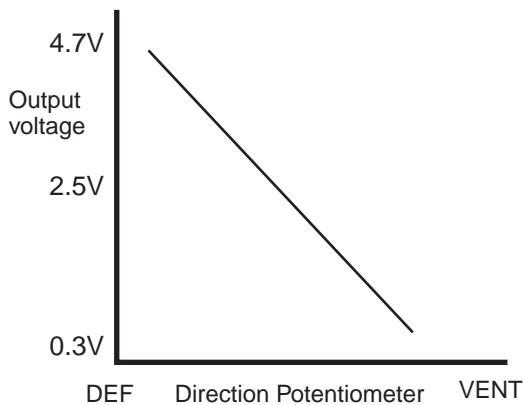
Check connectors for looseness, poor connection, bending, corrosion, contamination, deterioration, or damage. Repair or replace as necessary and then go to "Verification of Vehicle Repair" procedure.

NO

Substitute with a known-good actuator and check for proper operation. If the problem is corrected, replace actuator and then go to "Verification of Vehicle Repair" procedure.

VERIFICATION OF VEHICLE REPAIR

E91467DF

After a repair, it is essential to verify that the fault has been corrected.

1. Connect scantool and select "Diagnostic Trouble Codes(DTCs)" mode and then clear DTC.
2. Operate the vehicle and monitor the DTC on the scantool.
3. Are any DTCs present?

YES

Go to the applicable troubleshooting procedure.

NO

System is performing to specification at this time.

BLOWER AND A/C CONTROLS (AUTOMATIC)

HA -107

DTC B1250 DIRECTION POTENTIOMETER SHORT (HIGH) - DRIVER

COMPONENT LOCATION E7A14EE9

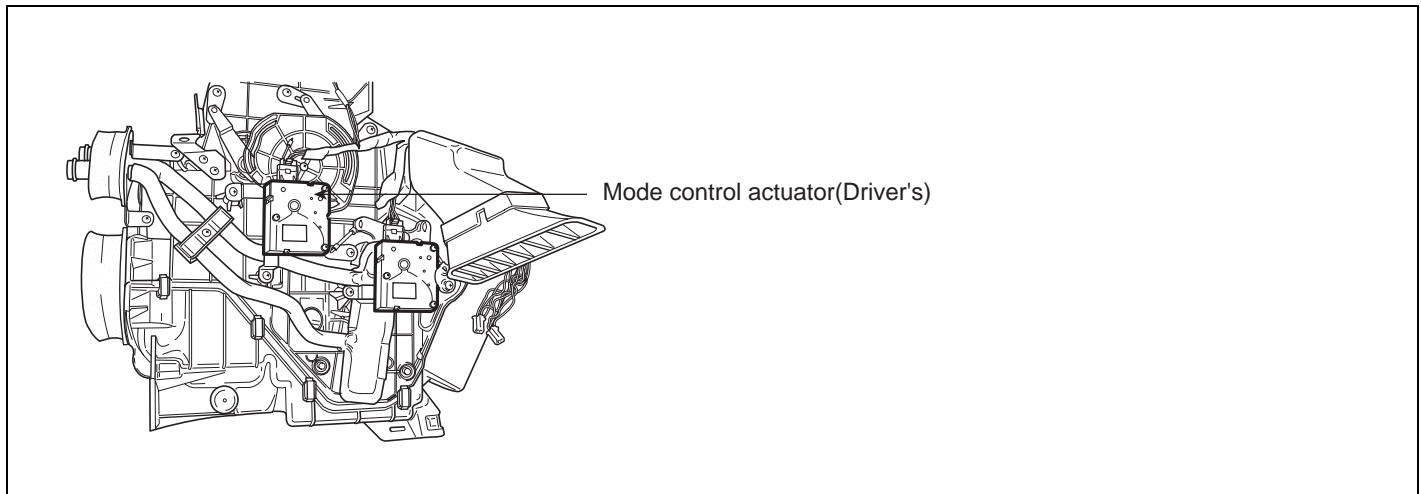

SGHHA6264L

GENERAL DESCRIPTION EFF51040

Refer to DTC B1249.

DTC DESCRIPTION E7165A71

The A/C controller sets DTC B1250 if there is a short to power in the Direction potentiometer.

DTC DETECTING CONDITION EB80C5E2

Item	Detecting Condition	Possible cause
DTC Strategy	<ul style="list-style-type: none"> Voltage check 	<ul style="list-style-type: none"> Short circuit in harness Faulty driver direction potentiometer Open circuit in harness
Threshold value	<ul style="list-style-type: none"> > 4.9V 	
Detecting time	<ul style="list-style-type: none"> 0.3 sec 	
FAIL SAFE	<ul style="list-style-type: none"> Fix vent position 	

SPECIFICATION E9D32086

Refer to DTC B1249.

MONITOR SCANTOOL DATA EC6E29FF

1. Connect scantool to Data Link Connector(DLC).
2. Engine "ON"
3. Monitor the "DR. DIRECTION POTENTIO." parameter on the scantool while operating mode switch.

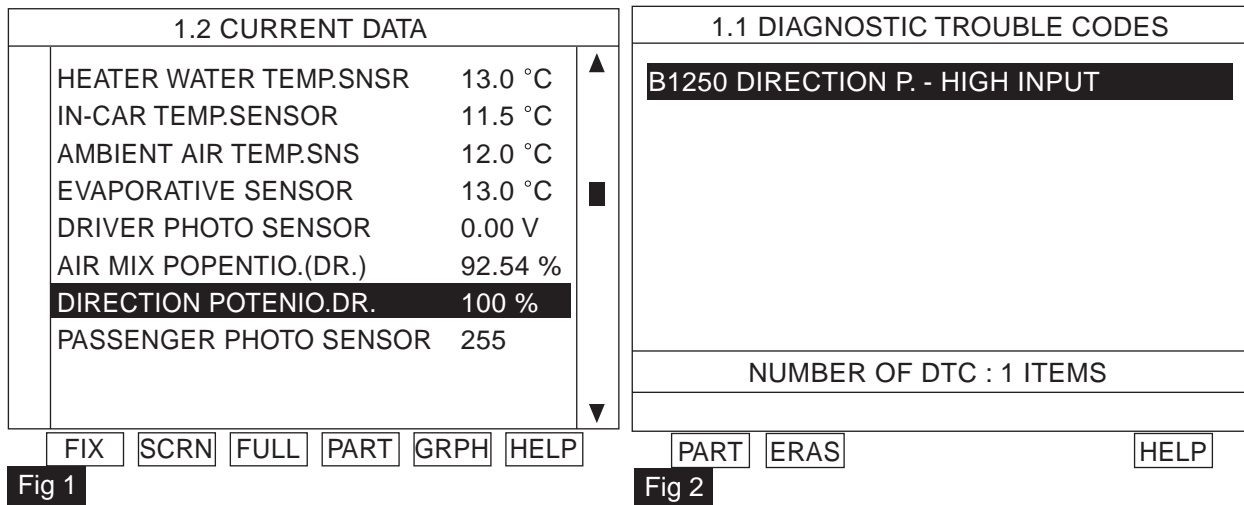

Fig 1 : The current data in abnormal state.

Fig 2 : DTC B1250.

LQIE524A

4. Are the DTC B1250 present and is parameter of "DR. DIRECTION POTENTIO." fixed?

Parameter of "DR. DIRECTION POTENTIO." will be fixed at 100%(or any value above 90%), or 0% (or any value below 10%), if there is any fault in Driver Direction potentiometer.

YES

Go to "Inspection" procedure.

NO

Fault is intermittent caused by poor contact in the sensor's and/or A/C controller's connector or was repaired and A/C controller memory was not cleared. Thoroughly check connectors for looseness, poor connection, bending, corrosion, contamination, deterioration, or damage. Repair or replace as necessary and then go to "Verification of Vehicle Repair" procedure.

TERMINAL AND CONNECTOR INSPECTION E39777D7

Refer to DTC B1249.

SIGNAL CIRCUIT INSPECTION E6AEFA86

- Check for short in harness.
 - Ignition "OFF"
 - Disconnect Driver mode Actuator.
 - Measure resistance between terminal "4" and "5" of Driver Direction potentiometer.

Specification : Approx.

BLOWER AND A/C CONTROLS (AUTOMATIC)

HA -109

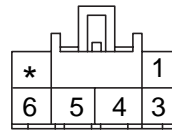
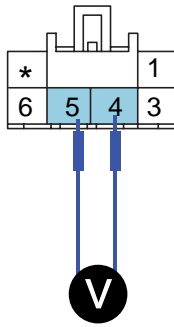

- 1. Motor
- 3. Motor
- 4. Sensor reference voltage(+5V)
- 5. Potentiometer signal
- 6. Potentiometer ground

SGHHA6214L

4) Is the measured resistance within specifications?

YES

Go to "Ground circuit inspection" procedure.

NO

Check for open in signal harness. Repair as necessary and go to "Verification of Vehicle Repair" procedure.

GROUND CIRCUIT INSPECTION EACE16BC

1. Check for open in ground harness.

- 1) Ignition "OFF"
- 2) Disconnect Driver mode Actuator.
- 3) Measure resistance between terminal "6" of evaporator sensor and chassis ground.

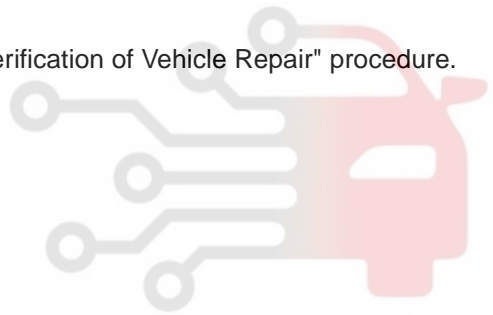

Specification :Approx. 0

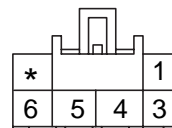
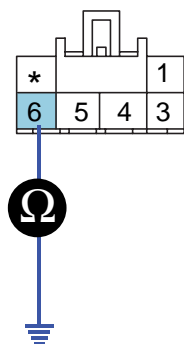

- 1. Motor
- 3. Motor
- 4. Sensor reference voltage(+5V)
- 5. Potentiometer signal
- 6. Potentiometer ground

SGHHA6215L

HA -110

HEATING, VENTILATION AND AIR CONDITIONING

4) Is the measured resistance within specifications?

YES

Go to "Component Inspection " procedure.

NO

Check for open in ground harness. Repair as necessary and go to "Verification of Vehicle Repair" procedure.

COMPONENT INSPECTION E7EF0619

Refer to DTC B1249.

VERIFICATION OF VEHICLE REPAIR EC873A38

Refer to DTC B1249.

دیجیتال خودرو

شرکت دیجیتال خودرو سامانه (مسئولیت محدود)

اولین سامانه دیجیتال تعمیرکاران خودرو در ایران



BLOWER AND A/C CONTROLS (AUTOMATIC)

HA -111

DTC B2406 AIR MIX MOTOR (DRIVER)

COMPONENT LOCATION E184C6F5

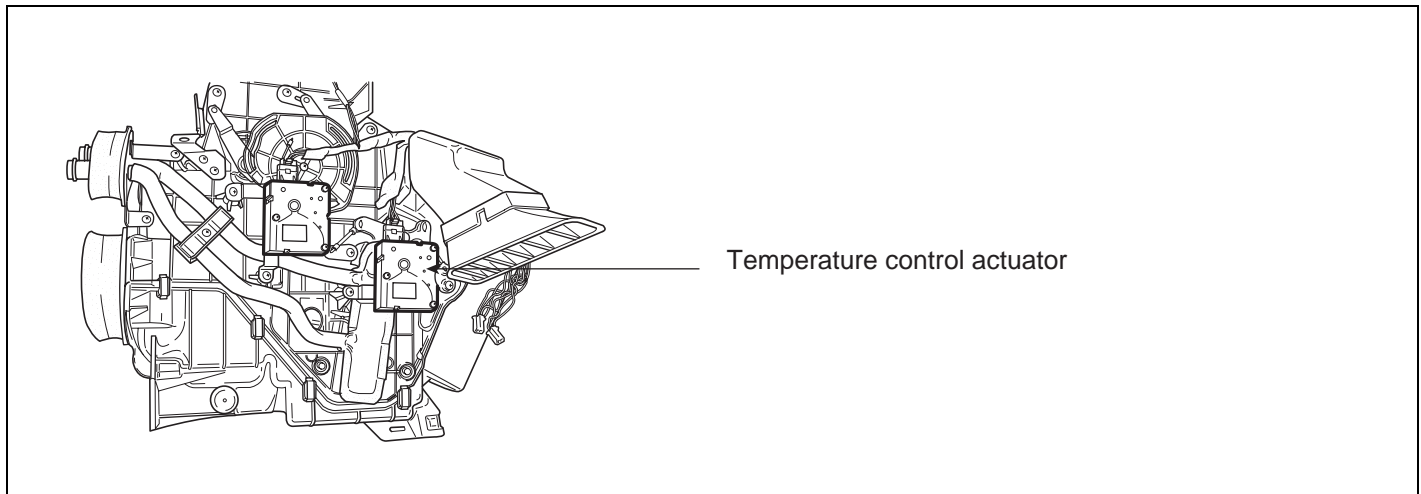

SGHHA6257L

GENERAL DESCRIPTION E75F6D6A

Temperature control actuator located at heater unit, regulates the temperature by the procedure as follows. Signal from control unit adjusts position of temp. door by operating temp. motor and then temperature will be regulated by the hot/cold air ratio decided by position of temp. door.

DTC DESCRIPTION E541ED3E

The A/C controller sets DTC B2406 if the air mix actuator doesn't move to intended position within 40sec (In this case, A/C controller try to move temp. door for 2sec. 3 times, every 20 sec. before setting DTC).

DTC DETECTING CONDITION ECDEEBFB

Item	Detecting Condition	Possible cause
DTC Strategy	<ul style="list-style-type: none"> Voltage check 	<ul style="list-style-type: none"> Poor connection of connected part Open circuit in harness Short circuit in harness Faulty driver Air Mix potentiometer Fault A/C Control Unit
Threshold value	<ul style="list-style-type: none"> 0.5 < Voltage < 4.5V 	
Detecting time	<ul style="list-style-type: none"> 40 sec 	
FAIL SAFE	-	

HA -112

HEATING, VENTILATION AND AIR CONDITIONING

SPECIFICATION E941A631

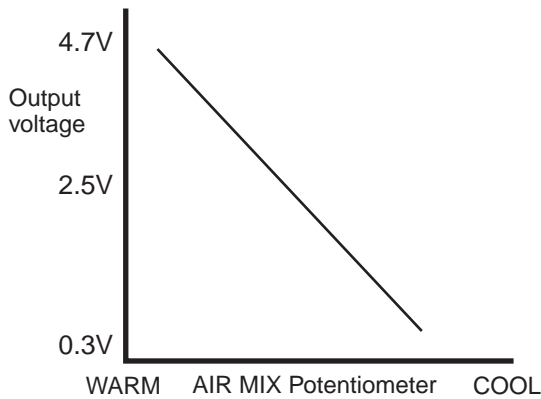

EQBF521B

MONITOR SCANTOOL DATA E514CDC7

1. Connect scantool to Data Link Connector(DLC).
2. Engine "ON"
3. Monitor the "Driver Air Mix Potentiometer" Parameter on the Scantool while operating temp. switch.

1.2 CURRENT DATA	
HEATER WATER TEMP.SNSR	14.0 °C
IN-CAR TEMP.SENSOR	12.0 °C
AMBIENT AIR TEMP.SNS	12.0 °C
EVAPORATIVE SENSOR	13.0 °C
DRIVER PHOTO SENSOR	0.00 V
AIR MIX POPENIO.(DR.)	22.7 %
DIRECTION POTENIO.DR.	51.76 %
PASSENGER PHOTO SENSOR	255

Fig. 1

1.1 DIAGNOSTIC TROUBLE CODES	
B2406 DRIVER AIR MIX MOTOR	
NUMBER OF DTC : 1 ITEMS	

Fig. 2

Fig 1 : The current data in abnormal state.

Fig 2 : DTC B2406.

EQBF525A

4. Are the DTC B2406 present and is parameter of "Driver AIR MIX Potentiometer" fixed?
 There is any fault in Driver AIR MIX Motor. If the parameter of "Driver AIR MIX DOOR" is 30% or less when the actuator operates to the hot position, or If the parameter is 60% and more when the actuator operates to the cold position.

YES

Go to "Inspection" procedure.

BLOWER AND A/C CONTROLS (AUTOMATIC)

HA -113

NO

Fault is intermittent caused by poor contact in the sensor's and/or A/C controller's connector or was repaired and A/C controller memory was not cleared. Thoroughly check connectors for looseness, poor connection, bending, corrosion, contamination, deterioration, or damage. Repair or replace as necessary and then go to "Verification of Vehicle Repair" procedure.

TERMINAL AND CONNECTOR INSPECTION E5D77EFA

1. Many malfunctions in the electrical system are caused by poor harness and terminals. Faults can also be caused by interference from other electrical systems, and mechanical or chemical damage.
2. Thoroughly check connectors for looseness, poor connection, bending, corrosion, contamination, deterioration, or damage.
3. Has a problem been found?

YES

Repair as necessary and go to "Verification of Vehicle Repair" procedure.

NO

Go to "Signal circuit inspection" procedure.

SIGNAL CIRCUIT INSPECTION ECD3FC90

1. Check for open in harness.

1) Ignition "OFF"

2) Disconnect Driver Air Mix potentiometer.

3) Measure resistance between terminal "1,3" of Driver Air Mix Motor and terminal "8,18" of A/C control unit.



Specification : Approx. 0

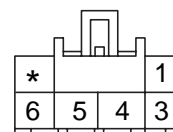
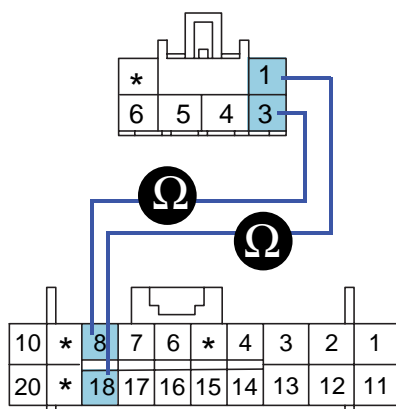

1. Motor

3. Motor

4. Sensor reference voltage(+5V)

5. Potentiometer signal

6. Potentiometer ground

SGHHA6238L

HA -114

HEATING, VENTILATION AND AIR CONDITIONING

4) Is the measured resistance within specifications?

YES

Go to "Check for short to ground in harness" procedure.

NO

Check for open in signal harness. Repair as necessary and go to "Verification of Vehicle Repair" procedure.

2. Check for short to ground in harness.

- 1) Ignition "OFF"
- 2) Disconnect Driver Air Mix Actuator.
- 3) Measure resistance between terminal "1,3" of Driver Air Mix Motor and chassis ground.

Specification : Approx.



SGHHA6239L

4) Is the measured resistance within specifications?

YES

Go to "Visual/Physical Inspection " procedure.

NO

Check for short to ground in signal harness. Repair as necessary and go to "Verification of Vehicle Repair" procedure.

VISUAL/PHYSICAL INSPECTION

E32E7A93

1. Check actuator.

Check if Driver Air Mix Actuator works properly through ACTUATION TEST.

- 1) Ignition : ON
- 2) Connect Scantool and select " ACTUATION TEST" mode and press [F1]

BLOWER AND A/C CONTROLS (AUTOMATIC)

HA -115

1.3 ACTUATION TEST	
DRIVER AIR MIX DOOR - DRIVE 50%	
DURATION	UNTIL STOP KEY
METHOD	ACTIVATION
CONDITION	IG. KEY ON ENGINE RUNNING
PRESS [STRT], IF YOU ARE READY!	
[STRT]	[STOP]

Fig. 3

Fig 3 : Selecting "ACTUATION TEST" mode.

EQBF525D

3) Does Driver Air Mix Actuator work properly?

YES

Go to "Component Inspection" procedure.

NO

Check connectors for looseness, poor connection, bending, corrosion, contamination, deterioration, or damage. Repair or replace as necessary and then go to "Verification of Vehicle Repair" procedure.

COMPONENT INSPECTION

E5A4009B

1. Check actuator motor.

- 1) Ignition "OFF"
- 2) Disconnect Driver Air Mix Potentiometer.
- 3) Verify that the temperature actuator operates to the hot position when connecting 12V to the terminal "1" and grounding terminal "3".
- 4) Verify that the temperature actuator operates to the cool position when the connections are reversed.

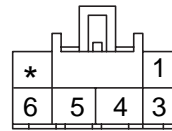
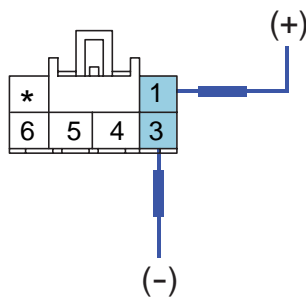

- 1. Motor
- 3. Motor
- 4. Sensor reference voltage(+5V)
- 5. Potentiometer signal
- 6. Potentiometer ground

SGHHA6212L

5) Does the actuator work properly?

YES

Go to "Check potentiometer" procedure.

NO

Substitute with a known-good actuator and check for proper operation. If the problem is corrected, replace actuator and then go to "Verification of Vehicle Repair" procedure.

2. Check potentiometer

1) Ignition "ON"

2) Connect Driver Air Mix potentiometer.

3) Measure voltage between terminal "5" and "6" of Driver Air Mix potentiometer while operating the temp. switch.

Specification : Refer the specifications in fig 3)

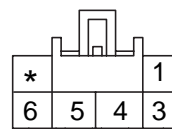
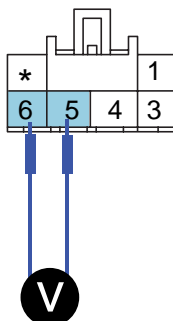

- 1. Motor
- 3. Motor
- 4. Sensor reference voltage(+5V)
- 5. Potentiometer signal
- 6. Potentiometer ground

SGHHA6213L

Door position	Voltage (5-6)	Error detecting
MAX. Cooling	0.3 ± 0.15V	Low voltage : 0.08V or less
MAX. Heating	4.7 ± 0.15V	High voltage : 4.9V or more

BLOWER AND A/C CONTROLS (AUTOMATIC)

HA -117

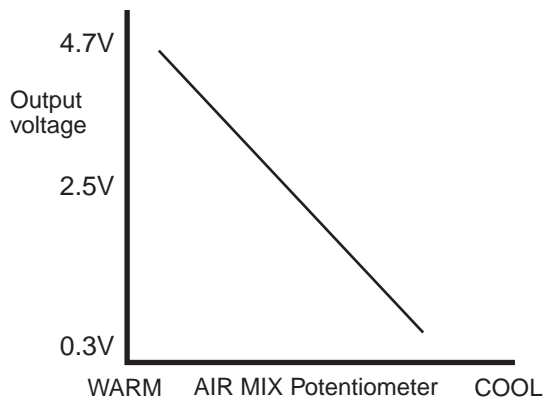

Fig. 3

Fig 3) Specifications : Voltage value of air mix potentiometer as a function of position of setting temperature.

EQBF521J

4) Is the measured voltage within specifications in fig3?

YES

Check connectors for looseness, poor connection, bending, corrosion, contamination, deterioration, or damage. Repair or replace as necessary and then go to "Verification of Vehicle Repair" procedure.

NO

Substitute with a known-good actuator and check for proper operation. If the problem is corrected, replace actuator and then go to "Verification of Vehicle Repair" procedure.

3. Check A/C Control Unit.

- 1) Engine "ON"
- 2) Connect A/C Control Unit.
- 3) Measure voltage between terminal "8" and "18" of A/C Control Unit while operating the temp. switch.

Specification :Approx. 12V

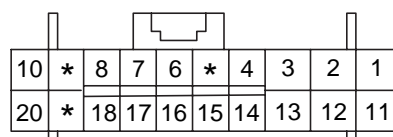
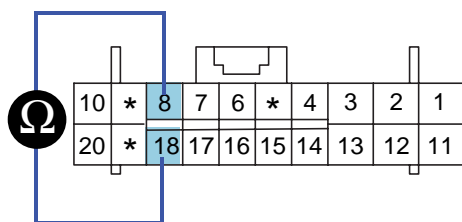

8. Motor
18. Motor

SGHHA6240L

HA -118

HEATING, VENTILATION AND AIR CONDITIONING

- 4) Is the measured voltage within specifications?

YES

Check connectors for looseness, poor connection, bending, corrosion, contamination, deterioration, or damage. Repair or replace as necessary and then go to "Verification of Vehicle Repair" procedure.

NO

Substitute with a known-good A/C Control Unit and check for proper operation.

If the problem is corrected, replace A/C Control Unit and then go to "Verification of Vehicle Repair" procedure.

VERIFICATION OF VEHICLE REPAIR EBAD7A4F

After a repair, it is essential to verify that the fault has been corrected.

1. Connect scantool and select "Diagnostic Trouble Codes(DTCs)" mode and then clear DTC.
2. Operate the vehicle and monitor the DTC on the scantool.
3. Are any DTCs present?

YES

Go to the applicable troubleshooting procedure.

NO

System is performing to specification at this time.

اولین سامانه دیجیتال تعمیرکاران خودرو در ایران



BLOWER AND A/C CONTROLS (AUTOMATIC)

HA -119

DTC B2409 DIRECTION CONTROL MOTOR (DRIVER)

COMPONENT LOCATION E01CDEE8

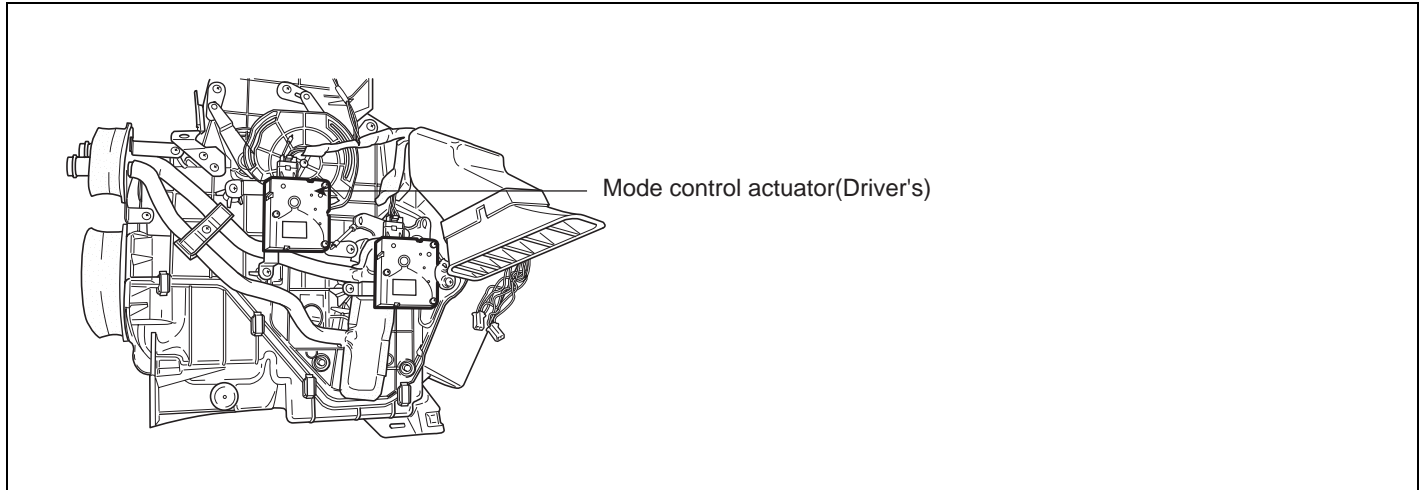

SGHHA6264L

GENERAL DESCRIPTION E42F32DF

Refer to DTC B1249.

DTC DESCRIPTION E842897E

The A/C controller sets DTC B2409 if the direction motor doesn't move to intended position within 40sec(In this case, A/C controller try to move mode door for 2sec. 3 times, every 20 sec. before setting DTC).

DTC DETECTING CONDITION EEF3F56C

Item	Detecting Condition	Possible cause
DTC Strategy	<ul style="list-style-type: none"> Voltage check 	<ul style="list-style-type: none"> Poor connection of connected part Open circuit in harness Short circuit in harness Faulty driver direction potentiometer Fault A/C Control Unit.
Threshold value	<ul style="list-style-type: none"> $0.5 < \text{Voltage} < 4.5V$ 	
Detecting time	<ul style="list-style-type: none"> 0.3 sec 	
FAIL SAFE	-	

SPECIFICATION EFC66FF1

Refer to DTC B1249.

MONITOR SCANTOOL DATA E5274229

1. Connect scantool to Data Link Connector(DLC).
2. Engine "ON"
3. Monitor the "DR DIRECTION POTENTIO" parameter on the scantool while operating mode switch.

1.2 CURRENT DATA	
HEATER WATER TEMP.SNSR	14.0 °C
IN-CAR TEMP.SENSOR	12.0 °C
AMBIENT AIR TEMP.SNS	12.0 °C
EVAPORATIVE SENSOR	13.0 °C
DRIVER PHOTO SENSOR	0.00 V
AIR MIX POPENIO.(DR.)	84.69 %
DIRECTION POTENIO.DR.	32.5 %
PASSENGER PHOTO SENSOR	255

Fig 1

1.1 DIAGNOSTIC TROUBLE CODES	
B2409 DRIVER DIRECTION MOTOR	
NUMBER OF DTC : 1 ITEMS	

Fig 2

Fig 1 : The current data in abnormal state.
Fig 2 : DTC B2409.

LQIE526A

4. Are the DTC B2409 present and is parameter of "Driver DIRECTION POTENTIO." fixed?
There is any fault in Driver Direction Motor. If the parameter of "Driver DIRECTION POTENTIO." is 10% or less on "VENT" mode, or If the parameter is 90% or more on "DEF" mode.

YES

Go to "Inspection" procedure.

NO

Fault is intermittent caused by poor contact in the sensor's and/or A/C controller's connector or was repaired and A/C controller memory was not cleared. Thoroughly check connectors for looseness, poor connection, bending, corrosion, contamination, deterioration, or damage. Repair or replace as necessary and then go to "Verification of Vehicle Repair" procedure.

TERMINAL AND CONNECTOR INSPECTION E25FB2CA

Refer to DTC B1249.

SIGNAL CIRCUIT INSPECTION EBE2C0ED

- Check for open in harness.
 - Ignition "OFF"
 - Disconnect Driver mode Actuator.
 - Measure resistance between terminal "1,3" of Driver Direction Motor and terminal "6,16" of A/C control unit.

Specification : Approx. 0

BLOWER AND A/C CONTROLS (AUTOMATIC)

HA -121

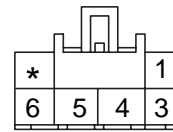
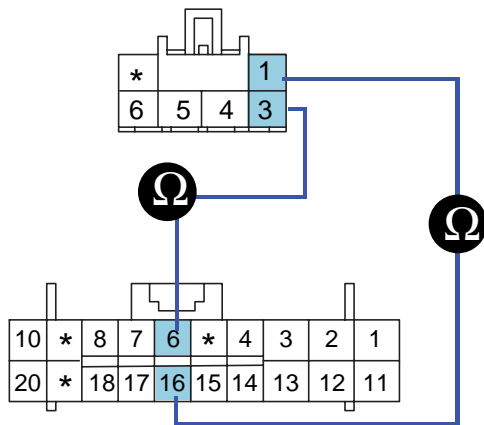

- 1. Motor
- 3. Motor
- 4. Sensor reference voltage(+5V)
- 5. Potentiometer signal
- 6. Potentiometer ground

SGHHA6242L

4) Is the measured resistance within specifications?

YES

Go to "Check for short to ground in harness" procedure.

NO

Check for open in signal harness. Repair as necessary and go to "Verification of Vehicle Repair" procedure.

2. Check for short to ground in harness.

1) Ignition "OFF"

2) Disconnect Driver mode Actuator.

3) Measure resistance between terminal "1,3" of Driver Direction Motor and chassis ground.

Specification : Approx.

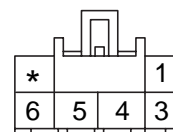
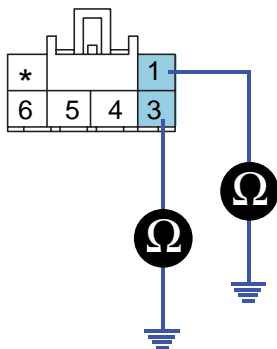

- 1. Motor
- 3. Motor
- 4. Sensor reference voltage(+5V)
- 5. Potentiometer signal
- 6. Potentiometer ground

SGHHA6239L

4) Is the measured resistance within specifications?

YES

Go to "Visual/Physical Inspection " procedure.

HA -122

HEATING, VENTILATION AND AIR CONDITIONING

NO

Check for short to ground in signal harness. Repair as necessary and go to "Verification of Vehicle Repair" procedure.

VISUAL/PHYSICAL INSPECTION ECA92423

1. Check actuator.
Check if Driver Direction Actuator works properly through ACTUATION TEST.
 - 1) Ignition : ON
 - 2) Connect Scantool and select " ACTUATION TEST" mode and press [F1]

1.3 ACTUATION TEST	
DRIVER AIR OUTLET MODE-DRIVE FOOT	
DURATION	UNTIL STOP KEY
METHOD	ACTIVATION
CONDITION	IG. KEY ON ENGINE RUNNING
PRESS [STRT], IF YOU ARE READY!	
[STRT]	[STOP]

Fig 3 شرکت دیجیتال خودرو سامانه (مسئولیت مح)

Fig 3 : Selecting "ACTUATION TEST" mode.

اولین سامانه دیجیتال تعمیرکاران خودرو در ایران



LQIE526D

- 3) Does Driver Direction Actuator work properly?

YES

Go to "Component Inspection" procedure.

NO

Check connectors for looseness, poor connection, bending, corrosion, contamination, deterioration, or damage. Repair or replace as necessary and then go to "Verification of Vehicle Repair" procedure.

COMPONENT INSPECTION EFC36697

Refer to DTC B1249.

VERIFICATION OF VEHICLE REPAIR E90CE672

Refer to DTC B1249.

BLOWER AND A/C CONTROLS (AUTOMATIC)

HA -123

DTC B2415 AIR MIX MOTOR (PASSENGER)

COMPONENT LOCATION EF994C56

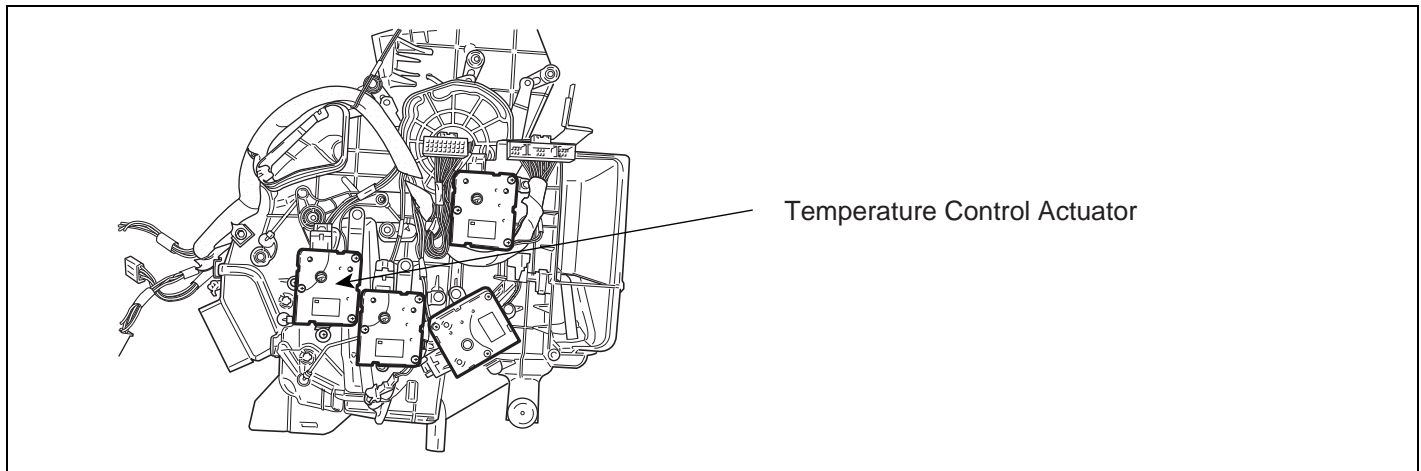

SGHHA6254L

GENERAL DESCRIPTION E64AC948

Temperature control actuator located at heater unit, regulates the temperature by the procedure as follows. Signal from control unit adjusts position of temp. door by operating temp. motor and then temperature will be regulated by the hot/cold air ratio decided by position of temp. door.

DTC DESCRIPTION E2ABFEF5

The A/C controller sets DTC B2415 if the air mix actuator doesn't move to intended position within 40sec (In this case, A/C controller try to move temp. door for 2sec. 3 times, every 20 sec. before setting DTC).

DTC DETECTING CONDITION EA8F2B90

Item	Detecting Condition	Possible cause
DTC Strategy	<ul style="list-style-type: none"> Voltage check 	<ul style="list-style-type: none"> Poor connection of connected part Open circuit in harness Short circuit in harness Faulty driver Air Mix potentiometer Fault A/C Control Unit
Threshold value	<ul style="list-style-type: none"> $0.5 < \text{Voltage} < 4.5V$ 	
Detecting time	<ul style="list-style-type: none"> 40 sec 	
FAIL SAFE	-	

HA -124

HEATING, VENTILATION AND AIR CONDITIONING

SPECIFICATION EC47D91F

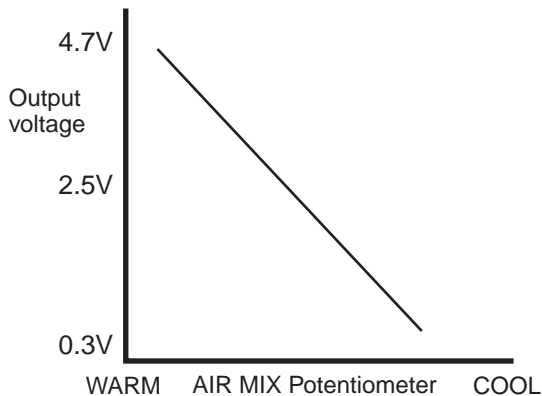

EQBF521B

MONITOR SCANTOOL DATA E41751B0

1. Connect scantool to Data Link Connector(DLC).
2. Engine "ON"
3. Monitor the "Passenger Air Mix Potentiometer" Parameter on the Scantool while operating temp. switch.

1.2 CURRENT DATA	
HEATER WATER TEMP.SNSR	14.0 °C
IN-CAR TEMP.SENSOR	12.0 °C
AMBIENT AIR TEMP.SNS	12.0 °C
EVAPORATIVE SENSOR	13.0 °C
DRIVER PHOTO SENSOR	0.00 V
AIR MIX POPENIO.(PA.)	22.7 %
DIRECTION POTENIO.DR.	51.76 %
PASSENGER PHOTO SENSOR	255

FIX | SCRN | FULL | PART | GRPH | HELP

Fig. 1

1.1 DIAGNOSTIC TROUBLE CODES	
B2415 PASSENGER AIR MIX MOTOR	
NUMBER OF DTC : 1 ITEMS	

PART | ERAS | HELP

Fig. 2

Fig 1 : The current data in abnormal state.

Fig 2 : DTC B2415.

LQKG990J

4. Are the DTC B2415 present and is parameter of "Passenger AIR MIX Potentiometer" fixed?
There is any fault in Passenger AIR MIX Motor. If the parameter of "Passenger AIR MIX DOOR" is 30% or less when the actuator operates to the hot position, or If the parameter is 60% and more when the actuator operates to the cold position.

YES

Go to "Inspection" procedure.

BLOWER AND A/C CONTROLS (AUTOMATIC)

HA -125

NO

Fault is intermittent caused by poor contact in the sensor's and/or A/C controller's connector or was repaired and A/C controller memory was not cleared. Thoroughly check connectors for looseness, poor connection, bending, corrosion, contamination, deterioration, or damage. Repair or replace as necessary and then go to "Verification of Vehicle Repair" procedure.

TERMINAL AND CONNECTOR INSPECTION E7F42C7B

1. Many malfunctions in the electrical system are caused by poor harness and terminals. Faults can also be caused by interference from other electrical systems, and mechanical or chemical damage.
2. Thoroughly check connectors for looseness, poor connection, bending, corrosion, contamination, deterioration, or damage.
3. Has a problem been found?

YES

Repair as necessary and go to "Verification of Vehicle Repair" procedure.

NO

Go to "Signal circuit inspection" procedure.

SIGNAL CIRCUIT INSPECTION EAE92A03

1. Check for open in harness.
 - 1) Ignition "OFF"
 - 2) Disconnect Passenger Air Mix potentiometer.
 - 3) Measure resistance between terminal "1,3" of Passenger Air Mix Motor and terminal "7,17" of A/C control unit.



Specification : Approx. 0

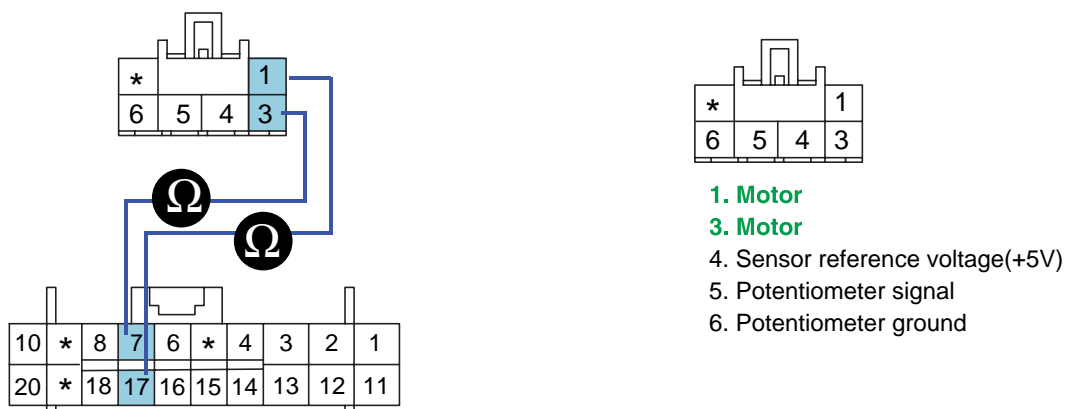

SGHHA6244L

HA -126

HEATING, VENTILATION AND AIR CONDITIONING

4) Is the measured resistance within specifications?

YES

Go to "Check for short to ground in harness" procedure.

NO

Check for open in signal harness. Repair as necessary and go to "Verification of Vehicle Repair" procedure.

2. Check for short to ground in harness.

- 1) Ignition "OFF"
- 2) Disconnect Passenger Air Mix Actuator.
- 3) Measure resistance between terminal "1,3" of Passenger Air Mix Motor and chassis ground.

Specification : Approx.



SGHHA6239L

4) Is the measured resistance within specifications?

YES

Go to "Visual/Physical Inspection " procedure.

NO

Check for short to ground in signal harness. Repair as necessary and go to "Verification of Vehicle Repair" procedure.

VISUAL/PHYSICAL INSPECTION

E991C1F7

1. Check actuator.

Check if Passenger Air Mix Actuator works properly through ACTUATION TEST.

- 1) Ignition : ON
- 2) Connect Scantool and select " ACTUATION TEST" mode and press [F1]

BLOWER AND A/C CONTROLS (AUTOMATIC)

HA -127

1.3 ACTUATION TEST	
PASSENGER AIR MIX DOOR - PASSENGER 50%	
DURATION	UNTIL STOP KEY
METHOD	ACTIVATION
CONDITION	IG. KEY ON ENGINE RUNNING
PRESS [STRT], IF YOU ARE READY!	
[STRT]	[STOP]

Fig. 3

Fig 3 : Selecting "ACTUATION TEST" mode.

LQKG525D

3) Does Passenger Air Mix Actuator work properly?

YES

Go to "Component Inspection" procedure.

NO

Check connectors for looseness, poor connection, bending, corrosion, contamination, deterioration, or damage. Repair or replace as necessary and then go to "Verification of Vehicle Repair" procedure.

COMPONENT INSPECTION E076DD0D

1. Check actuator motor.

- 1) Ignition "OFF"
- 2) Disconnect Passenger Air Mix Potentiometer.
- 3) Verify that the temperature actuator operates to the hot position when connecting 12V to the terminal "1" and grounding terminal "3".
- 4) Verify that the temperature actuator operates to the cool position when the connections are reversed.

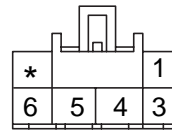
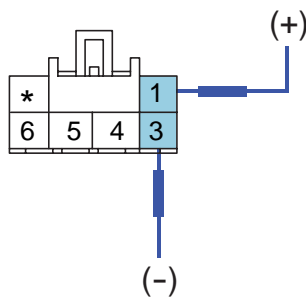

- 1. Motor
- 3. Motor
- 4. Sensor reference voltage(+5V)
- 5. Potentiometer signal
- 6. Potentiometer ground

SGHHA6212L

5) Does the actuator work properly?

YES

Go to "Check potentiometer" procedure.

NO

Substitute with a known-good actuator and check for proper operation. If the problem is corrected, replace actuator and then go to "Verification of Vehicle Repair" procedure.

2. Check potentiometer

- 1) Ignition "ON"
- 2) Connect Passenger Air Mix potentiometer.
- 3) Measure voltage between terminal "5" and "6" of Passenger Air Mix potentiometer while operating the temp. switch.

Specification : Refer the specifications in fig 3)

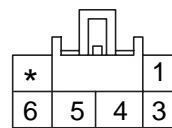
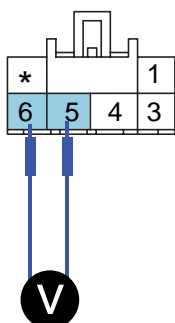

- 1. Motor
- 3. Motor
- 4. Sensor reference voltage(+5V)
- 5. Potentiometer signal
- 6. Potentiometer ground

SGHHA6213L

Door position	Voltage (5-6)	Error detecting
MAX. Cooling	0.3 ± 0.15V	Low voltage : 0.08V or less
MAX. Heating	4.7 ± 0.15V	High voltage : 4.9V or more

BLOWER AND A/C CONTROLS (AUTOMATIC)

HA -129

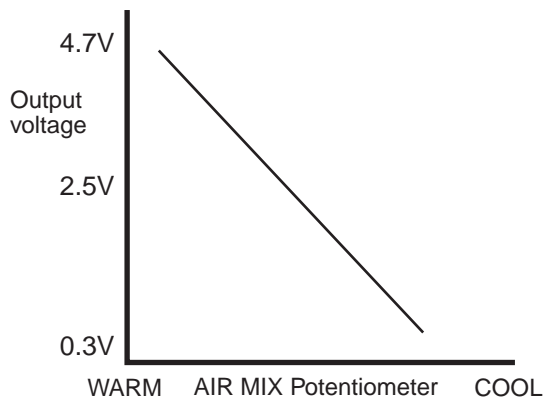

Fig. 3

Fig 3) Specifications : Voltage value of air mix potentiometer as a function of position of setting temperature.

EQBF521J

4) Is the measured voltage within specifications in fig3?

YES

Check connectors for looseness, poor connection, bending, corrosion, contamination, deterioration, or damage. Repair or replace as necessary and then go to "Verification of Vehicle Repair" procedure.

NO

Substitute with a known-good actuator and check for proper operation. If the problem is corrected, replace actuator and then go to "Verification of Vehicle Repair" procedure.

3. Check A/C Control Unit.

- 1) Engine "ON"
- 2) Connect A/C Control Unit.
- 3) Measure voltage between terminal "7" and "17" of A/C Control Unit while operating the temp. switch.

Specification :Approx. 12V

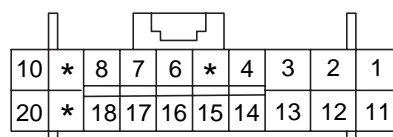
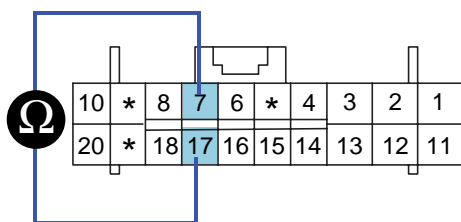

7. Motor
17. Motor

SGHHA6245L

HA -130

HEATING, VENTILATION AND AIR CONDITIONING

4) Is the measured voltage within specifications?

YES

Check connectors for looseness, poor connection, bending, corrosion, contamination, deterioration, or damage. Repair or replace as necessary and then go to "Verification of Vehicle Repair" procedure.

NO

Substitute with a known-good A/C Control Unit and check for proper operation.

If the problem is corrected, replace A/C Control Unit and then go to "Verification of Vehicle Repair" procedure.

VERIFICATION OF VEHICLE REPAIR E9F02EC4

After a repair, it is essential to verify that the fault has been corrected.

1. Connect scantool and select "Diagnostic Trouble Codes(DTCs)" mode and then clear DTC.
2. Operate the vehicle and monitor the DTC on the scantool.
3. Are any DTCs present?

YES

Go to the applicable troubleshooting procedure.

NO

System is performing to specification at this time.

اولین سامانه دیجیتال تعمیرکاران خودرو در ایران



BLOWER AND A/C CONTROLS (AUTOMATIC)

HA -131

DTC B2416 DIRECTION CONTROL MOTOR (PASSENGER)

COMPONENT LOCATION E1CF7CAD

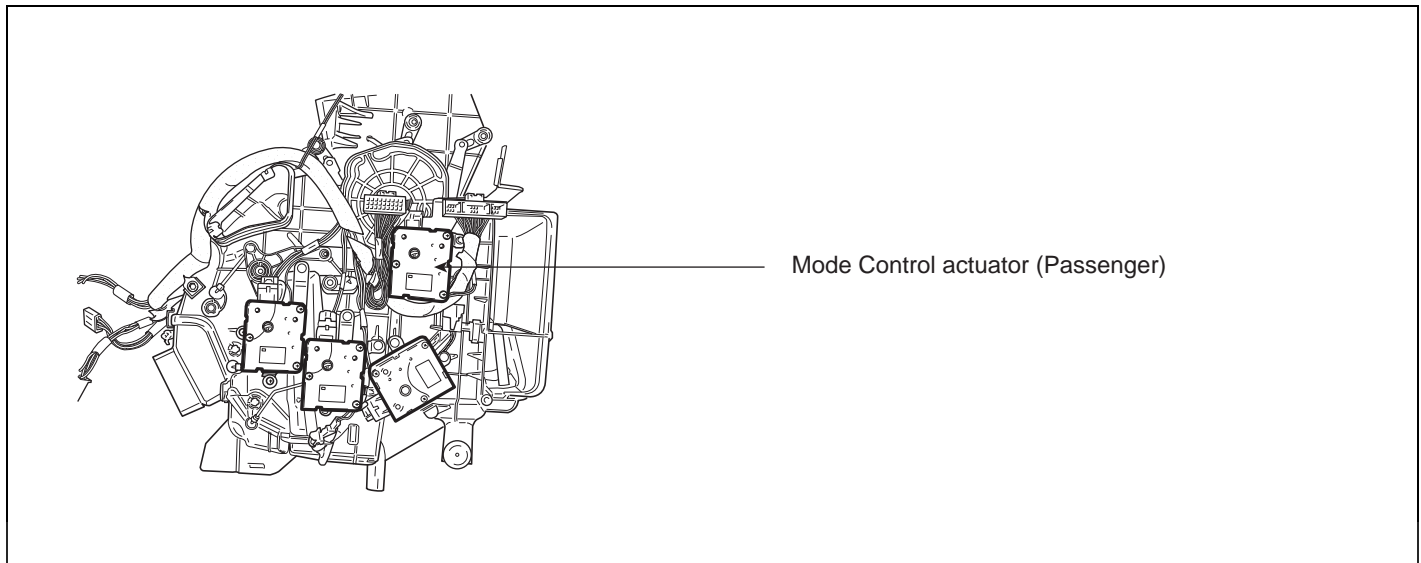

SGHHA6258L

GENERAL DESCRIPTION EF5781CF

The mode control actuator mounted on heater unit, adjusts position of mode door by operating Direction Motor based on signal of A/C control unit. Pressing mode select switch makes the mode control actuator shift in order of vent B/L floor mix.

DTC DESCRIPTION EC2E4DF8

The A/C controller sets DTC B2416 if the direction motor doesn't move to intended position within 40sec(In this case, A/C controller try to move mode door for 2sec. 3 times, every 20 sec. before setting DTC).

DTC DETECTING CONDITION EC90DC02

Item	Detecting Condition	Possible cause
DTC Strategy	<ul style="list-style-type: none"> Voltage check 	<ul style="list-style-type: none"> Poor connection of connected part Open circuit in harness Short circuit in harness Faulty driver direction potentiometer Fault A/C Control Unit.
Threshold value	<ul style="list-style-type: none"> 0.5 < Voltage < 4.5V 	
Detecting time	<ul style="list-style-type: none"> 40 sec 	
FAIL SAFE	-	

HA -132

HEATING, VENTILATION AND AIR CONDITIONING

SPECIFICATION E463272E

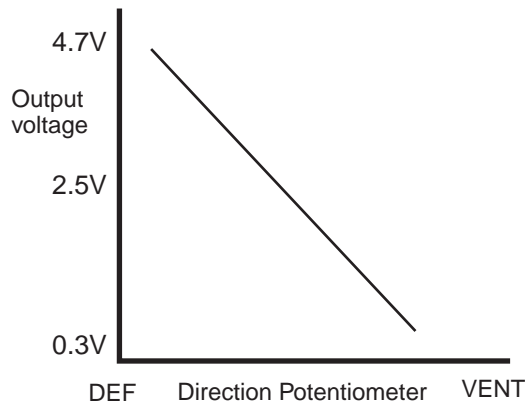

EQBF523B

MONITOR SCANTOOL DATA E65417DD

1. Connect scantool to Data Link Connector(DLC).
2. Engine "ON"
3. Monitor the "PA DIRECTION POTENTIO" parameter on the scantool while operating mode switch.

1.2 CURRENT DATA	
HEATER WATER TEMP.SNSR	14.0 °C
IN-CAR TEMP.SENSOR	12.0 °C
AMBIENT AIR TEMP.SNS	12.0 °C
EVAPORATIVE SENSOR	13.0 °C
DRIVER PHOTO SENSOR	0.00 V
AIR MIX POPENTIO.(DR.)	84.69 %
DIRECTION POTENIO.PA.	32.5 %
PASSENGER PHOTO SENSOR	255

Fig. 1

1.1 DIAGNOSTIC TROUBLE CODES	
B2416 PASSENGER DIRECTION MOTOR	
NUMBER OF DTC : 1 ITEMS	

Fig. 2

Fig 1 : The current data in abnormal state.

Fig 2 : DTC B2416.

LQKG990M

4. Are the DTC B2416 present and is parameter of "Passenger DIRECTION POTENTIO." fixed?
There is any fault in Passenger Direction Motor. If the parameter of "Passenger DIRECTION POTENTIO." is 10% or less on "VENT" mode, or If the parameter is 90% or more on "DEF" mode.

YES

Go to "Inspection" procedure.

BLOWER AND A/C CONTROLS (AUTOMATIC)

HA -133

NO

Fault is intermittent caused by poor contact in the sensor's and/or A/C controller's connector or was repaired and A/C controller memory was not cleared. Thoroughly check connectors for looseness, poor connection, bending, corrosion, contamination, deterioration, or damage. Repair or replace as necessary and then go to "Verification of Vehicle Repair" procedure.

TERMINAL AND CONNECTOR INSPECTION E445635C

1. Many malfunctions in the electrical system are caused by poor harness and terminals. Faults can also be caused by interference from other electrical systems, and mechanical or chemical damage.
2. Thoroughly check connectors for looseness, poor connection, bending, corrosion, contamination, deterioration, or damage.
3. Has a problem been found?

YES

Repair as necessary and go to "Verification of Vehicle Repair" procedure.

NO

Go to "Signal circuit inspection" procedure.

SIGNAL CIRCUIT INSPECTION E1953B5C

1. Check for open in harness.
 - 1) Ignition "OFF"
 - 2) Disconnect Passenger mode Actuator.
 - 3) Measure resistance between terminal "1,3" of Passenger Direction Motor and terminal "5,15" of A/C control unit.



Specification : Approx. 0

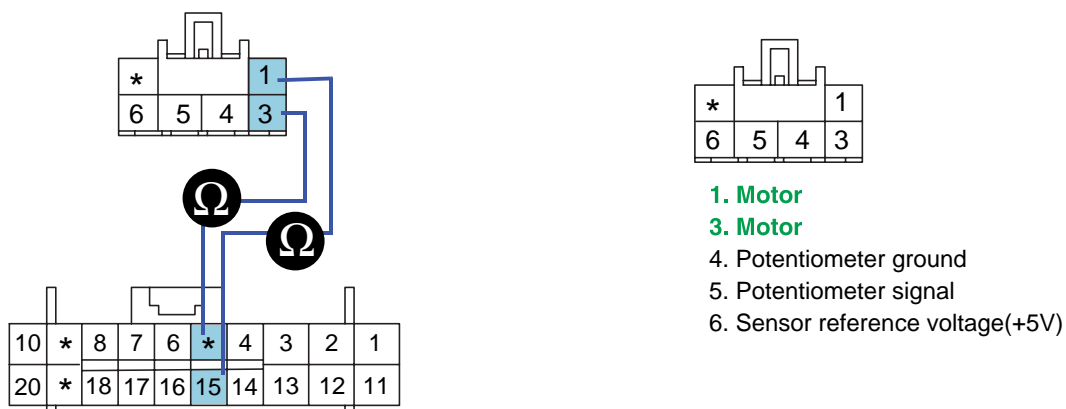

SGHHA6246L

HA -134

HEATING, VENTILATION AND AIR CONDITIONING

4) Is the measured resistance within specifications?

YES

Go to "Check for short to ground in harness" procedure.

NO

Check for open in signal harness. Repair as necessary and go to "Verification of Vehicle Repair" procedure.

2. Check for short to ground in harness.

- 1) Ignition "OFF"
- 2) Disconnect Passenger mode Actuator.
- 3) Measure resistance between terminal "1,3" of Passenger Direction Motor and chassis ground.

Specification : Approx.



SGHHA6239L

4) Is the measured resistance within specifications?

YES

Go to "Visual/Physical Inspection " procedure.

NO

Check for short to ground in signal harness. Repair as necessary and go to "Verification of Vehicle Repair" procedure.

VISUAL/PHYSICAL INSPECTION

E50E56B6

1. Check actuator.

Check if Passenger Direction Actuator works properly through ACTUATION TEST.

- 1) Ignition : ON
- 2) Connect Scantool and select " ACTUATION TEST" mode and press [F1]

BLOWER AND A/C CONTROLS (AUTOMATIC)

HA -135

1.3 ACTUATION TEST	
PASSENGER AIR OUTLET MODE-PASSENGER FOOT	
DURATION	UNTIL STOP KEY
METHOD	ACTIVATION
CONDITION	IG. KEY ON ENGINE RUNNING
PRESS [STRT], IF YOU ARE READY!	
[STRT]	[STOP]

Fig. 3

Fig 3 : Selecting "ACTUATION TEST" mode.

LQKG9900

3) Does Passenger Direction Actuator work properly?

YES

Go to "Component Inspection" procedure.

NO

Check connectors for looseness, poor connection, bending, corrosion, contamination, deterioration, or damage. Repair or replace as necessary and then go to "Verification of Vehicle Repair" procedure.

COMPONENT INSPECTION E2354556

1. Check actuator.

- 1) Ignition "OFF"
- 2) Disconnect Passenger Direction potentiometer.
- 3) Verify that the mode actuator operates to the vent mode when connecting 12V to the terminal "1 and grounding terminal "3.
- 4) Verify that the mode actuator operates to the def mode when the connections are reversed.

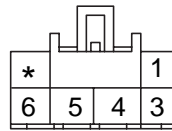
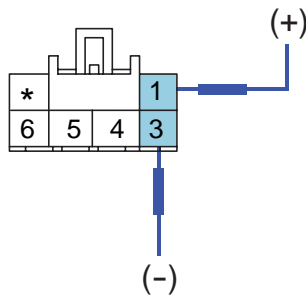

- 1. Motor
- 3. Motor
- 4. Sensor reference voltage(+5V)
- 5. Potentiometer signal
- 6. Potentiometer ground

SGHHA6212L

5) Does the actuator work properly?

YES

Go to "Check potentiometer" procedure.

NO

Substitute with a known-good actuator and check for proper operation. If the problem is corrected, replace actuator and then go to "Verification of Vehicle Repair" procedure.

2. Check potentiometer

- 1) Ignition "ON"
- 2) Connect Passenger Direction potentiometer.
- 3) Measure voltage between terminal "5" and "6" of Passenger Direction potentiometer as the mode switch is operated.

Specification : Refer the specifications in fig 3

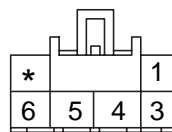
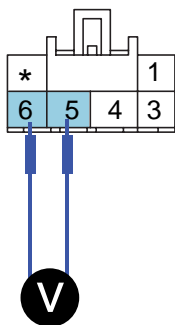

- 1. Motor
- 3. Motor
- 4. Sensor reference voltage(+5V)
- 5. Potentiometer signal
- 6. Potentiometer ground

SGHHA6213L

BLOWER AND A/C CONTROLS (AUTOMATIC)

HA -137

Door position	Voltage (5-6)	Error detecting
VENT	$0.3 \pm 0.15V$	Under voltage : 0.08V or less Over voltage : 4.92V or more
BI-LEVEL(1)	$1.35 \pm 0.4V$	
BI-LEVEL(2)	$2.25 \pm 0.4V$	
FLOOR	$3.0 \pm 0.4V$	
MIX	$3.6 \pm 0.4V$	
DEF	$4.7 \pm 0.15V$	

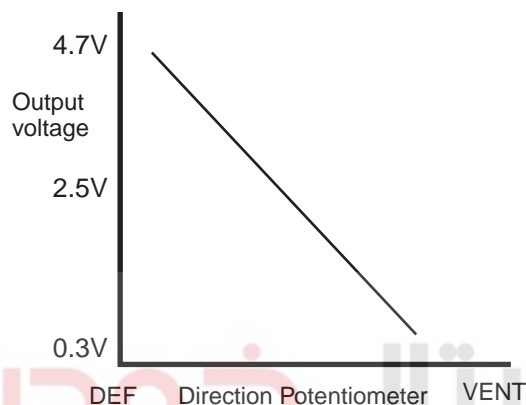

Fig. 3

(Fig 3) Specifications : Voltage value as a function of position of direction potentiometer.



EQBF523J

4) Is the measured voltage within specifications in fig3?

YES

Check connectors for looseness, poor connection, bending, corrosion, contamination, deterioration, or damage. Repair or replace as necessary and then go to "Verification of Vehicle Repair" procedure.

NO

Substitute with a known-good actuator and check for proper operation. If the problem is corrected, replace actuator and then go to "Verification of Vehicle Repair" procedure.

3. Check A/C Control Unit.

- 1) Engine : "ON"
- 2) Connect A/C Control Unit.
- 3) Measure voltage between terminal "5" and "15" of A/C Control Unit while operating the mode switch.

Specification : Approx. 12V

HA -138

HEATING, VENTILATION AND AIR CONDITIONING

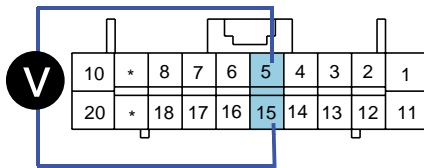

5 Motor
15. Motor

SGHHA6609L

4) Is the measured voltage within specifications?

YES

Check connectors for looseness, poor connection, bending, corrosion, contamination, deterioration, or damage. Repair or replace as necessary and then go to "Verification of Vehicle Repair" procedure.

NO

Substitute with a known-good A/C Control Unit and check for proper operation.

If the problem is corrected, replace A/C Control Unit and then go to "Verification of Vehicle Repair" procedure.

VERIFICATION OF VEHICLE REPAIR ED389E33

After a repair, it is essential to verify that the fault has been corrected.

1. Connect scantool and select "Diagnostic Trouble Codes(DTCs)" mode and then clear DTC.
2. Operate the vehicle and monitor the DTC on the scantool.
3. Are any DTCs present?

YES

Go to the applicable troubleshooting procedure.

NO

System is performing to specification at this time.

BLOWER AND A/C CONTROLS (AUTOMATIC)

HA -139

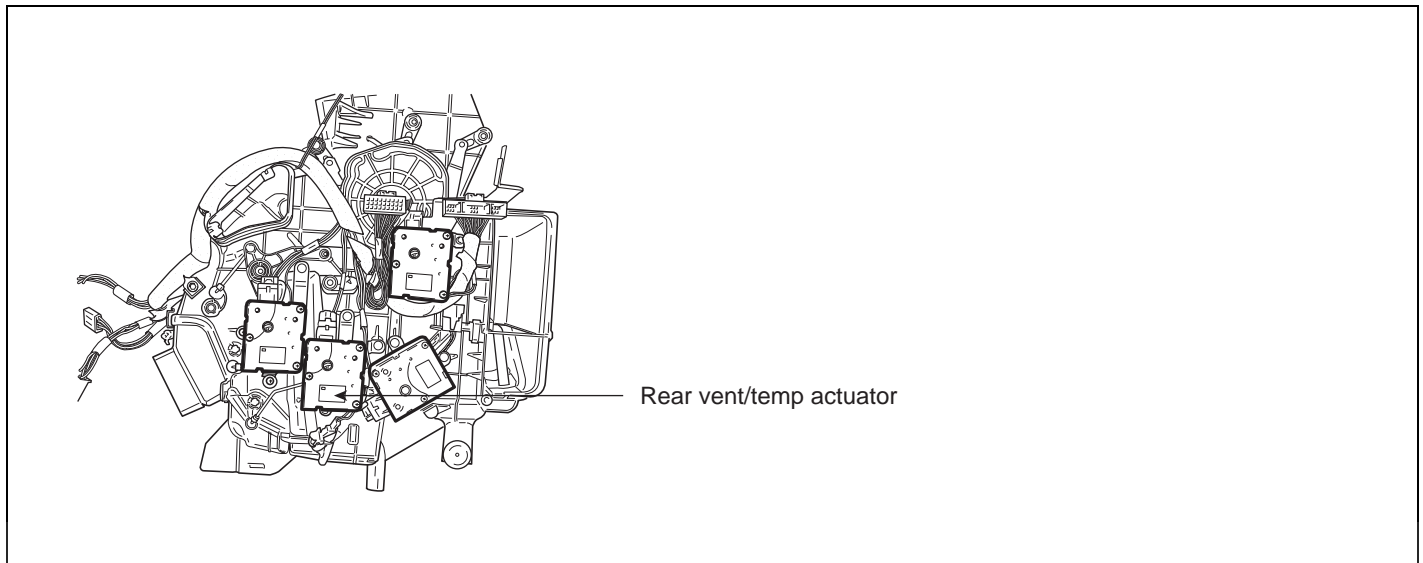
DTC B2417 AIR POTENTIOMETER OPEN (LOW) - REAR**COMPONENT LOCATION** E1CC59BD

SGHHA6261N

GENERAL DESCRIPTION E1E9D85D

Temperature control actuator located at heater unit, regulates the temperature by the procedure as follows. Signal from control unit adjusts position of temp. door by operating temp. motor and then temperature will be regulated by the hot/cold air ratio decided by position of temp. door.

DTC DESCRIPTION E6CA6DB0

The A/C controller sets DTC B2417 if there is an open circuit or poor connection in the air mix potentiometer.

DTC DETECTING CONDITION E4FD1E00

Item	Detecting Condition	Possible cause
DTC Strategy	<ul style="list-style-type: none"> Voltage check 	<ul style="list-style-type: none"> Poor connection of connected part Open circuit in harness Short circuit in harness Faulty driver Air Mix potentiometer
Threshold value	<ul style="list-style-type: none"> < 0.1V 	
Detecting time	<ul style="list-style-type: none"> 0.3 sec 	
FAIL SAFE	<ul style="list-style-type: none"> Fix at max. heating position 	

HA -140

HEATING, VENTILATION AND AIR CONDITIONING

SPECIFICATION EBD0952E

Rear vent temp S.W		Input Voltage (V)	Actuator voltage (V, ± 0.1V)
DETENT	Switch resistance (k)		
1	0.2 below	0.24 below	Max cooling position
2	0.5 ± 0.25	0.5 ± 0.25	0.74
3	1.0 ± 0.25	1.0 ± 0.25	0.74 ~ 4.26
4	1.5 ± 0.25	1.5 ± 0.25	
5	2.0 ± 0.25	2.0 ± 0.25	
6	2.5 ± 0.25	2.5 ± 0.25	
7	3.0 ± 0.25	3.0 ± 0.25	
8	3.5 ± 0.25	3.5 ± 0.25	
9	4.0 ± 0.25	4.0 ± 0.25	
10	4.5 ± 0.25	4.5 ± 0.25	
11	4.8 above	4.76 above	Max heating position

MONITOR SCANTOOL DATA E0A7C7FA

1. Connect scantool to Data Link Connector(DLC).
2. Engine "ON"
3. Monitor the "Rear Air Mix Potentiometer" Parameter on the Scantool while operating temp. switch.

1.2 CURRENT DATA

HEATER WATER TEMP.SNSR	13.0 °C
IN-CAR TEMP.SENSOR	12.0 °C
AMBIENT AIR TEMP.SNS	12.0 °C
EVAPORATIVE SENSOR	12.5 °C
DRIVER PHOTO SENSOR	0.00 V
AIR MIX POPENATIO.(REAR.)	5.9 %
DIRECTION POTENIO.DR.	90.18 %
PASSENGER PHOTO SENSOR	255

Fig 1

1.1 DIAGNOSTIC TROUBLE CODES

B2417 AIR MIX P. - LOW INPUT

NUMBER OF DTC : 1 ITEMS

Fig 2

Fig 1 : The current data in abnormal state.

Fig 2 : DTC B2417.

SUNHA6800N

BLOWER AND A/C CONTROLS (AUTOMATIC)

HA -141

4. Are the DTC B1260 present and is parameter of "Rear Air Mix Potentiometer" fixed?
Parameter of "Rear Air Mix Potentiometer" will be fixed at 100%(or any value above 90%), or 0% (or any value below 10%), if there is any fault in Rear Air Mix potentiometer.

YES

Go to "Inspection" procedure.

NO

Fault is intermittent caused by poor contact in the sensor's and/or A/C controller's connector or was repaired and A/C controller memory was not cleared. Thoroughly check connectors for looseness, poor connection, bending, corrosion, contamination, deterioration, or damage. Repair or replace as necessary and then go to "Verification of Vehicle Repair" procedure.

TERMINAL AND CONNECTOR INSPECTION E2CC09CB

- Many malfunctions in the electrical system are caused by poor harness and terminals. Faults can also be caused by interference from other electrical systems, and mechanical or chemical damage.
- Thoroughly check connectors for looseness, poor connection, bending, corrosion, contamination, deterioration, or damage.
- Has a problem been found?

YES

Repair as necessary and go to "Verification of Vehicle Repair" procedure.

NO

Go to "Signal circuit inspection" procedure.

SIGNAL CIRCUIT INSPECTION EA788F3A

- Check for open in harness.
 - Ignition "OFF"
 - Disconnect Rear vent/temp actuator.
 - Measure resistance between terminal "5" of Rear vent/temp actuator and terminal "15" of A/C control unit.

 Specification : Approx. 0

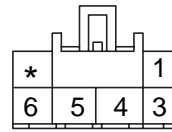
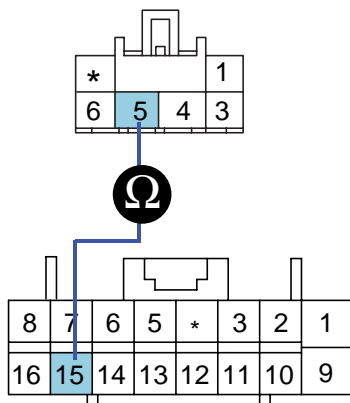

1. Motor (+)
3. Motor (-)
4. Sensor reference voltage(+5V)
5. Potentiometer signal
6. Potentiometer ground

SGHHA6249N

4) Is the measured resistance within specifications?

YES

Go to "Check for short to ground in harness" procedure.

NO

Check for open in signal harness. Repair as necessary and go to "Verification of Vehicle Repair" procedure.

2. Check for short to ground in harness.

1) Ignition "OFF"

2) Disconnect Rear vent/temp actuator.

3) Measure resistance between terminal "5" of Rear vent/temp actuator and chassis ground.

Specification : Approx.

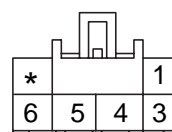
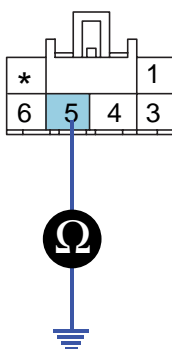

1. Motor (+)
3. Motor (-)
4. Sensor reference voltage(+5V)
5. Potentiometer signal
6. Potentiometer ground

SGHHA6250N

4) Is the measured resistance within specifications?

YES

Go to "Power circuit Inspection" procedure.

BLOWER AND A/C CONTROLS (AUTOMATIC)

HA -143

NO

Check for short to ground in signal harness. Repair as necessary and go to "Verification of Vehicle Repair" procedure.

POWER SUPPLY CIRCUIT INSPECTION E684952B

1. Check for short or open in harness.

- 1) Ignition "ON"
- 2) Connect Rear vent/temp actuator.
- 3) Measure voltage between terminal "4" of Rear vent/temp actuator and chassis ground.

Specification : Approx. 5V

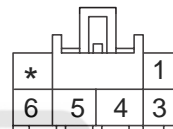
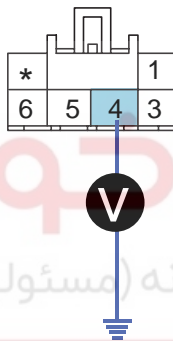

1. Motor (+)
3. Motor (-)
4. Sensor reference voltage(+5V)
5. Potentiometer signal
6. Potentiometer ground

اولین سامانه دیجیتال خودرو (مسئولیت محدود)

اولین سامانه دیجیتال تعمیرکاران خودرو در ایران

SGHHA6251N

4) Is the measured voltage within specifications?

YES

Go to "Component inspection" procedure.

NO

Check for short or open in power harness. Repair as necessary and go to "Verification of Vehicle Repair" procedure.

COMPONENT INSPECTION EF2EE96D

1. Check actuator motor.

- 1) Ignition "OFF"
- 2) Disconnect Rear vent/teemp actuator.
- 3) Verify that the temperature actuator operates to the hot position when connecting 12V to the terminal "1" and grounding terminal "3".
- 4) Verify that the temperature actuator operates to the cool position when the connections are reversed.

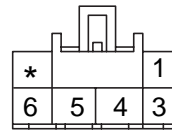
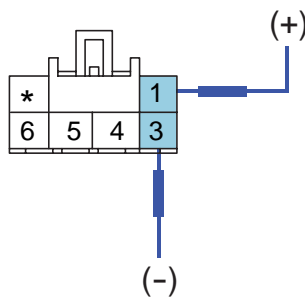

- 1. Motor
- 3. Motor
- 4. Sensor reference voltage(+5V)
- 5. Potentiometer signal
- 6. Potentiometer ground

SGHHA6212L

5) Does the actuator work properly?

YES

Go to "Check potentiometer" procedure.

NO

Substitute with a known-good actuator and check for proper operation. If the problem is corrected, replace actuator and then go to "Verification of Vehicle Repair" procedure.

2. Check potentiometer

- 1) Ignition "ON"
- 2) Connect Rear vent/teemp actuator.
- 3) Measure voltage between terminal "5" and "6" of Rear vent/teemp actuator while operating the temp. switch.

Specification : Refer the specifications in fig 3)

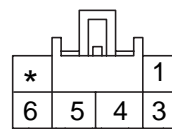
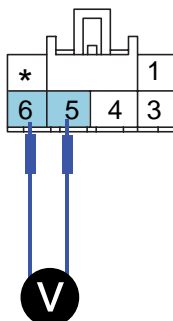

- 1. Motor
- 3. Motor
- 4. Sensor reference voltage(+5V)
- 5. Potentiometer signal
- 6. Potentiometer ground

SGHHA6213L

Door position	Voltage (5-6)	Error detecting
MAX. Cooling	0.3 ± 0.15V	Low voltage : 0.08V or less
MAX. Heating	4.7 ± 0.15V	High voltage : 4.9V or more

BLOWER AND A/C CONTROLS (AUTOMATIC)

HA -145

Rear vent temp S.W		Input Voltage (V)	Actuator voltage (V, $\pm 0.1V$)
DETENT	Switch resistance (k)		
1	0.2 below	0.24 below	Max cooling position
2	0.5 ± 0.25	0.5 ± 0.25	0.74
3	1.0 ± 0.25	1.0 ± 0.25	0.74 ~ 4.26
4	1.5 ± 0.25	1.5 ± 0.25	
5	2.0 ± 0.25	2.0 ± 0.25	
6	2.5 ± 0.25	2.5 ± 0.25	
7	3.0 ± 0.25	3.0 ± 0.25	
8	3.5 ± 0.25	3.5 ± 0.25	
9	4.0 ± 0.25	4.0 ± 0.25	
10	4.5 ± 0.25	4.5 ± 0.25	
11	4.8 above	4.76 above	Max heating position

4) Is the measured voltage within specifications in fig3?

YES

Check connectors for looseness, poor connection, bending, corrosion, contamination, deterioration, or damage. Repair or replace as necessary and then go to "Verification of Vehicle Repair" procedure.

NO

Substitute with a known-good actuator and check for proper operation. If the problem is corrected, replace actuator and then go to "Verification of Vehicle Repair" procedure.

VERIFICATION OF VEHICLE REPAIR EA8827C7

After a repair, it is essential to verify that the fault has been corrected.

1. Connect scantool and select "Diagnostic Trouble Codes(DTCs)" mode and then clear DTC.
2. Operate the vehicle and monitor the DTC on the scantool.
3. Are any DTCs present?

YES

Go to the applicable troubleshooting procedure.

NO

System is performing to specification at this time.

HA -146

HEATING, VENTILATION AND AIR CONDITIONING

DTC B2418 AIR POTENTIOMETER OPEN (HIGH) - REAR

COMPONENT LOCATION E385A9BF

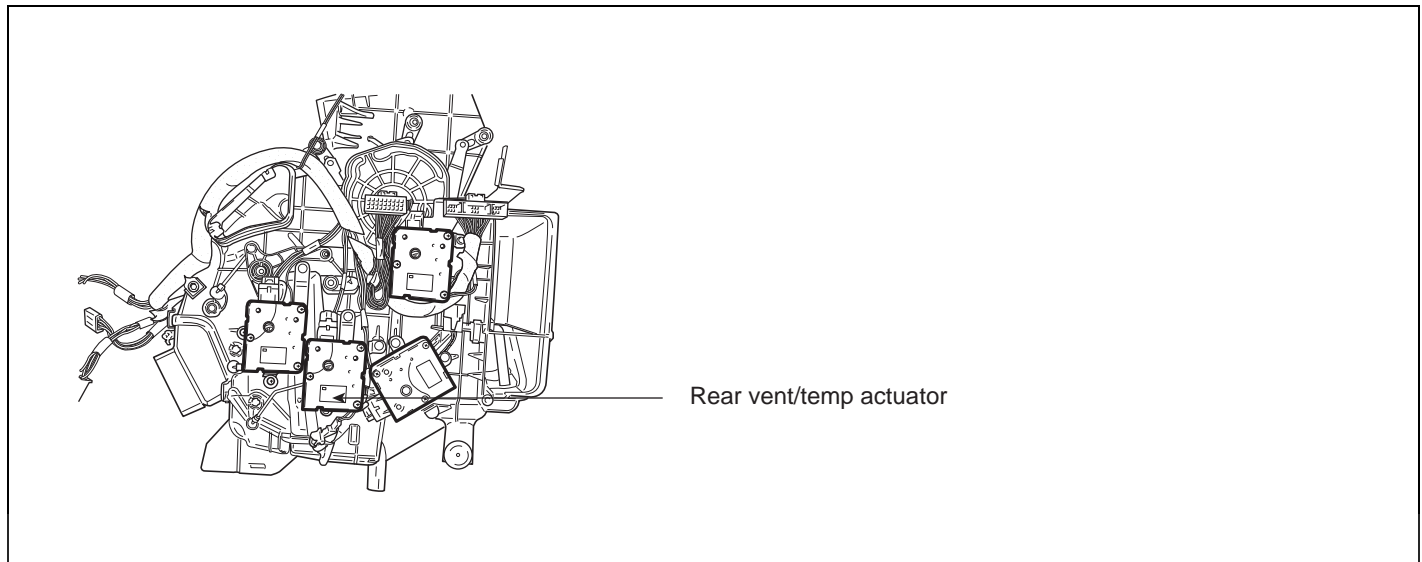

SGHHA6262N

GENERAL DESCRIPTION E34E2DBD

Refer to DTC B2417.

DTC DESCRIPTION EB07A910

The A/C controller sets DTC B2418 if there is a short to power in the air mix potentiometer.

DTC DETECTING CONDITION E58E5664

Item	Detecting Condition	Possible cause
DTC Strategy	<ul style="list-style-type: none"> Voltage check 	<ul style="list-style-type: none"> Short circuit in harness Faulty driver Air Mix potentiometer
Threshold value	<ul style="list-style-type: none"> > 4.9V 	
Detecting time	<ul style="list-style-type: none"> 0.3 sec 	
FAIL SAFE	<ul style="list-style-type: none"> If temperature setting 17~24.5°C(63~76°F) fix at max. cooling position. If temperature setting 25~32°C(77~90°F) fix at max. heating position. 	

SPECIFICATION EC11B0F8

Refer to DTC B2417.

MONITOR SCANTOOL DATA E2B835E6

1. Connect scantool to Data Link Connector(DLC).
2. Engine "ON"

BLOWER AND A/C CONTROLS (AUTOMATIC)

HA -147

3. Monitor the "Rear vent/temp actuator" Parameter on the Scantool while operating temp. switch.

1.2 CURRENT DATA	
HEATER WATER TEMP.SNSR	13.0 °C ▲
IN-CAR TEMP.SENSOR	12.0 °C
AMBIENT AIR TEMP.SNS	12.0 °C
EVAPORATIVE SENSOR	12.5 °C ■
DRIVER PHOTO SENSOR	0.00 V
AIR MIX POPENATIO.(REAR.)	5.9 %
DIRECTION POTENIO.DR.	90.18 %
PASSENGER PHOTO SENSOR	255

Fig 1

1.1 DIAGNOSTIC TROUBLE CODES	
B2418 AIR MIX P. - LOW INPUT	
NUMBER OF DTC : 1 ITEMS	

Fig 2

Fig 1 : The current data in abnormal state.

Fig 2 : DTC B2418.

SUNHA6801N

4. Are the DTC B1261 present and is parameter of "Rear Air Mix potentiometer" fixed?
 Parameter of "Rear vent/temp actuator" will be fixed at 100%(or any value above 90%), or 0% (or any value below 10%), if there is any fault in Rear vent/temp actuator.

YES

Go to "Inspection" procedure.

NO

Fault is intermittent caused by poor contact in the sensor's and/or A/C controller's connector or was repaired and A/C controller memory was not cleared. Thoroughly check connectors for looseness, poor connection, bending, corrosion, contamination, deterioration, or damage. Repair or replace as necessary and then go to "Verification of Vehicle Repair" procedure.

TERMINAL AND CONNECTOR INSPECTION E97C97D8

Refer to DTC B2417.

GROUND CIRCUIT INSPECTION E4734615

- Check for open in harness.
 - Ignition "OFF"
 - Disconnect Rear vent/temp actuator.
 - Measure resistance between terminal "6" of Rear vent/temp actuator and chassis ground.

Specification : Approx. 0

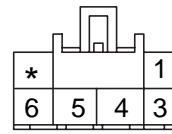
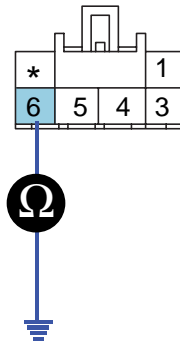

- 1. Motor (+)
- 2. Motor (-)
- 3. Sensor reference voltage(+5V)
- 4. Potentiometer signal
- 5. Potentiometer ground

SGHHA6215N

4) Is the measured resistance within specifications?

YES

Go to "Component Inspection" procedure.

NO

Check for open in ground harness. Repair as necessary and go to "Verification of Vehicle Repair" procedure.

COMPONENT INSPECTION E170DBEC

Refer to DTC B2417.

VERIFICATION OF VEHICLE REPAIR EAD48544

Refer to DTC B2417.

