

SECTION **DLN**
DRIVELINE

A
B
C
DLN

CONTENTS

TRANSFER: TY30A		
FUNCTION DIAGNOSIS	4	
4WD SYSTEM	4	
System Diagram	4	
System Description	6	
Component Parts Location	7	
Component Description	9	
COMPONENT DIAGNOSIS	10	
C1201 4WD CONTROL UNIT	10	
Description	10	
C1203 ABS ACTUATOR AND ELECTRIC UNIT (CONTROL UNIT)	11	
Description	11	
C1204 4WD SOLENOID	12	
Description	12	
Diagnosis Procedure	12	
Component Inspection	13	
C1205 4WD ACTUATOR RELAY	15	
Description	15	
C1209 MODE SW	16	
Description	16	
Diagnosis Procedure	16	
Component Inspection	17	
C1210 ECM	19	
Description	19	
U1000 CAN COMM CIRCUIT	20	
Description	20	
U1010 CONTROL UNIT (CAN)	21	
Description	21	
Diagnosis Procedure	21	
POWER SUPPLY AND GROUND CIRCUIT	22	
Description	22	F
Diagnosis Procedure	22	F
4WD WARNING LAMP	24	G
Description	24	G
4WD INDICATOR LAMP	25	H
Description	25	H
LOCK INDICATOR LAMP	26	I
Description	26	I
ECU DIAGNOSIS	27	
4WD CONTROL UNIT	27	J
Reference Value	27	J
Wiring Diagram - 4WD SYSTEM -	29	J
Fail Safe	29	J
SYMPTOM DIAGNOSIS	31	
4WD SYSTEM SYMPTOMS	31	L
Symptom Table	31	L
4WD WARNING LAMP DOES NOT TURN ON	32	M
Description	32	M
4WD WARNING LAMP DOES NOT TURN OFF	33	N
Description	33	N
HEAVY TIGHT-CORNER BRAKING SYMPTOM OCCURS	34	O
Description	34	O
VEHICLE DOES NOT ENTER 4WD MODE	35	P
Description	35	P
4WD WARNING LAMP BLINKS QUICKLY	36	
Description	36	
4WD WARNING LAMP BLINKS SLOWLY	37	
Description	37	

NORMAL OPERATING CONDITION	38	DISASSEMBLY AND ASSEMBLY	56
Description	38	ADAPTER CASE	56
NOISE, VIBRATION AND HARSHNESS (NVH) TROUBLESHOOTING	39	M/T	56
NVH Troubleshooting Chart	39	M/T : Exploded View	56
PRECAUTION	41	M/T : Disassembly	57
PRECAUTIONS	41	M/T : Assembly	57
Precaution for Supplemental Restraint System (SRS) "AIR BAG" and "SEAT BELT PRE-TENSIONER"	41	M/T : Inspection After Disassembly	58
Precaution for Procedure without Cowl Top Cover ..	41	CVT	58
Service Notice or Precautions for Transfer	41	CVT : Exploded View	59
PREPARATION	43	CVT : Disassembly	60
PREPARATION	43	CVT : Assembly	60
M/T	43	CVT : Inspection After Disassembly	61
M/T : Special Service Tools	43	RING GEAR SHAFT	62
M/T : Commercial Service Tools	45	M/T	62
CVT	46	M/T : Exploded View	62
CVT : Special Service Tools	46	M/T : Disassembly	63
CVT : Commercial Service Tools	48	M/T : Assembly	64
ON-VEHICLE MAINTENANCE	49	M/T : Inspection After Disassembly	65
TRANSFER OIL	49	CVT	65
Inspection	49	CVT : Exploded View	66
Draining	49	CVT : Disassembly	67
Refilling	49	CVT : Assembly	68
ON-VEHICLE REPAIR	50	CVT : Inspection After Disassembly	69
4WD CONTROL UNIT	50	DRIVE PINION	70
LHD	50	M/T	70
LHD : Exploded View	50	M/T : Exploded View	70
LHD : Removal and Installation	50	M/T : Disassembly	71
RHD	50	M/T : Assembly	72
RHD : Exploded View	51	M/T : Adjustment	73
RHD : Removal and Installation	51	M/T : Inspection After Disassembly	82
REMOVAL AND INSTALLATION	52	CVT	82
TRANSFER ASSEMBLY	52	CVT : Exploded View	83
MR20DE (M/T)	52	CVT : Disassembly	84
MR20DE (M/T) : Exploded View	52	CVT : Assembly	85
MR20DE (M/T) : Removal and Installation	52	CVT : Adjustment	86
MR20DE (CVT)	53	CVT : Inspection After Disassembly	95
MR20DE (CVT) : Exploded View	53	TRANSFER CASE	96
MR20DE (CVT) : Removal and Installation	53	M/T	96
M9R	54	M/T : Exploded View	96
M9R : Exploded View	54	M/T : Disassembly	97
M9R : Removal and Installation	55	M/T : Assembly	97
		M/T : Inspection	98
		CVT	98
		CVT : Exploded View	99
		CVT : Disassembly	100
		CVT : Assembly	100
		CVT : Inspection	101
		SERVICE DATA AND SPECIFICATIONS (SDS)	102

SERVICE DATA AND SPECIFICATIONS	ON-VEHICLE MAINTENANCE	115	
(SDS)	REAR DIFFERENTIAL GEAR OIL	115	A
General Specifications	Inspection	115	
Preload Torque	Draining	115	B
Backlash	Refilling	115	
Companion Flange Runout	ON-VEHICLE REPAIR	116	C
REAR PROPELLER SHAFT: 3F SPL18-DOJ75	FRONT OIL SEAL	116	
SYMPTOM DIAGNOSIS	Exploded View	116	
103	Removal and Installation	117	DLN
NOISE, VIBRATION AND HARSHNESS	SIDE OIL SEAL	119	
(NVH) TROUBLESHOOTING	Exploded View	119	E
103	Removal and Installation	119	
NVH Troubleshooting Chart	ELECTRIC CONTROLLED COUPLING	120	F
103	Exploded View	120	
ON-VEHICLE MAINTENANCE	Removal and Installation	121	
104	REMOVAL AND INSTALLATION	124	G
REAR PROPELLER SHAFT	REAR FINAL DRIVE ASSEMBLY	124	
104	Exploded View	124	H
Inspection	Removal and Installation	124	
ON-VEHICLE REPAIR	DISASSEMBLY AND ASSEMBLY	126	I
105	ELECTRIC CONTROLLED COUPLING	126	
REAR PROPELLER SHAFT	Exploded View	126	J
105	Disassembly	128	
Exploded View	Assembly	128	
105	Adjustment	130	
Removal and Installation	Inspection After Disassembly	130	
105	DIFFERENTIAL ASSEMBLY	131	K
Inspection	Exploded View	131	
107	Disassembly	133	
SERVICE DATA AND SPECIFICATIONS	Assembly	134	L
(SDS)	Inspection After Disassembly	137	
108	DRIVE PINION	138	M
SERVICE DATA AND SPECIFICATIONS	Exploded View	138	
(SDS)	Disassembly	139	
108	Assembly	141	
General Specifications	Adjustment	144	N
108	Inspection After Disassembly	147	
Propeller Shaft Runout	SERVICE DATA AND SPECIFICATIONS		O
108	(SDS)	149	
Journal Axial Play	SERVICE DATA AND SPECIFICATIONS		P
108	(SDS)	149	
REAR FINAL DRIVE: R145	General Specification	149	
SYMPTOM DIAGNOSIS	Drive Gear Runout	149	
109	Differential Side Gear Clearance	149	
NOISE, VIBRATION AND HARSHNESS	Preload Torque	149	
(NVH) TROUBLESHOOTING	Backlash	149	
109	Companion Flange Runout	149	
NVH Troubleshooting Chart			
109			
PRECAUTION			
110			
PRECAUTIONS			
110			
Service Notice or Precautions for Rear Final Drive. 110			
PREPARATION			
111			
PREPARATION			
111			
Special Service Tools			
111			
Commercial Service Tools			
112			
FUNCTION DIAGNOSIS			
114			
REAR FINAL DRIVE ASSEMBLY			
114			
System Diagram			
114			

FUNCTION DIAGNOSIS

4WD SYSTEM

System Diagram

INFOID:000000004905364

CONTROL DIAGRAM

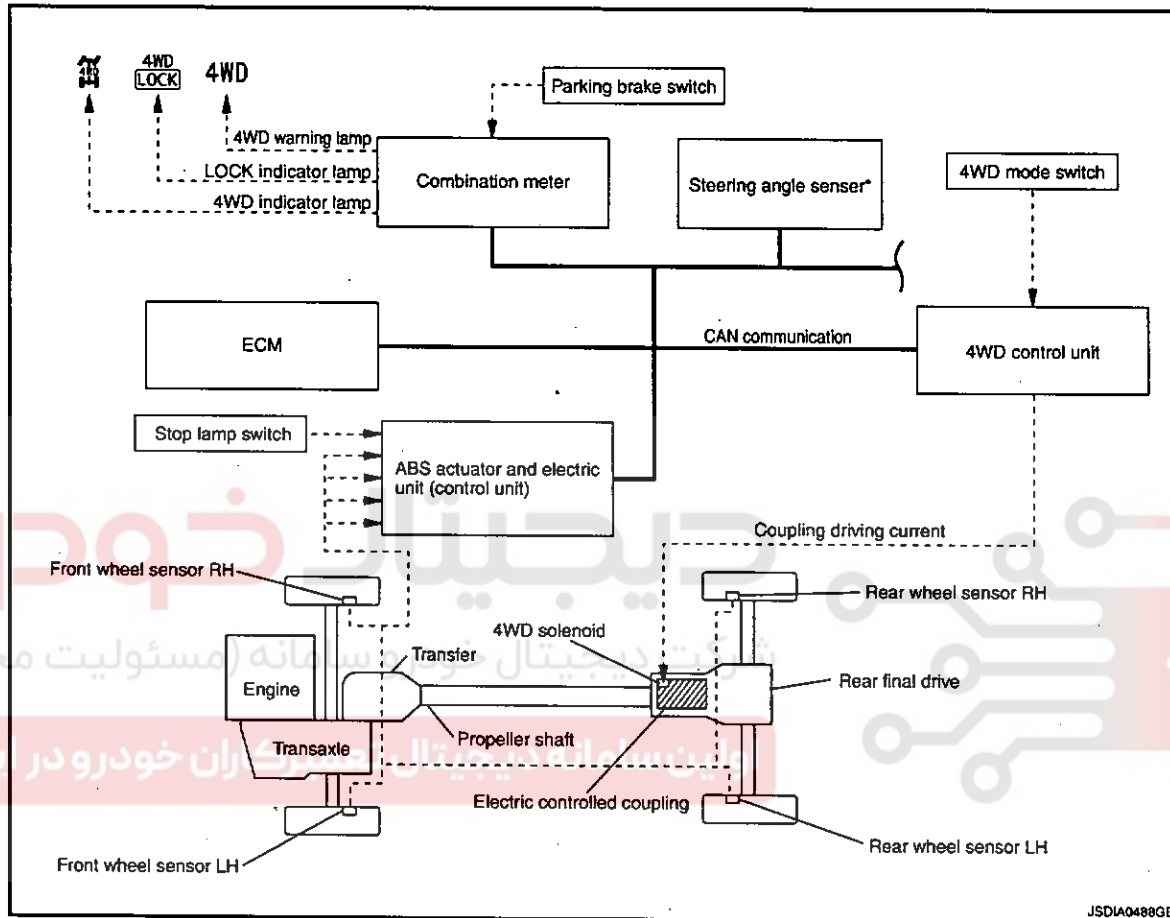

JSDIA0489GB

*: With VDC

CROSS-SECTIONAL VIEW (M/T)

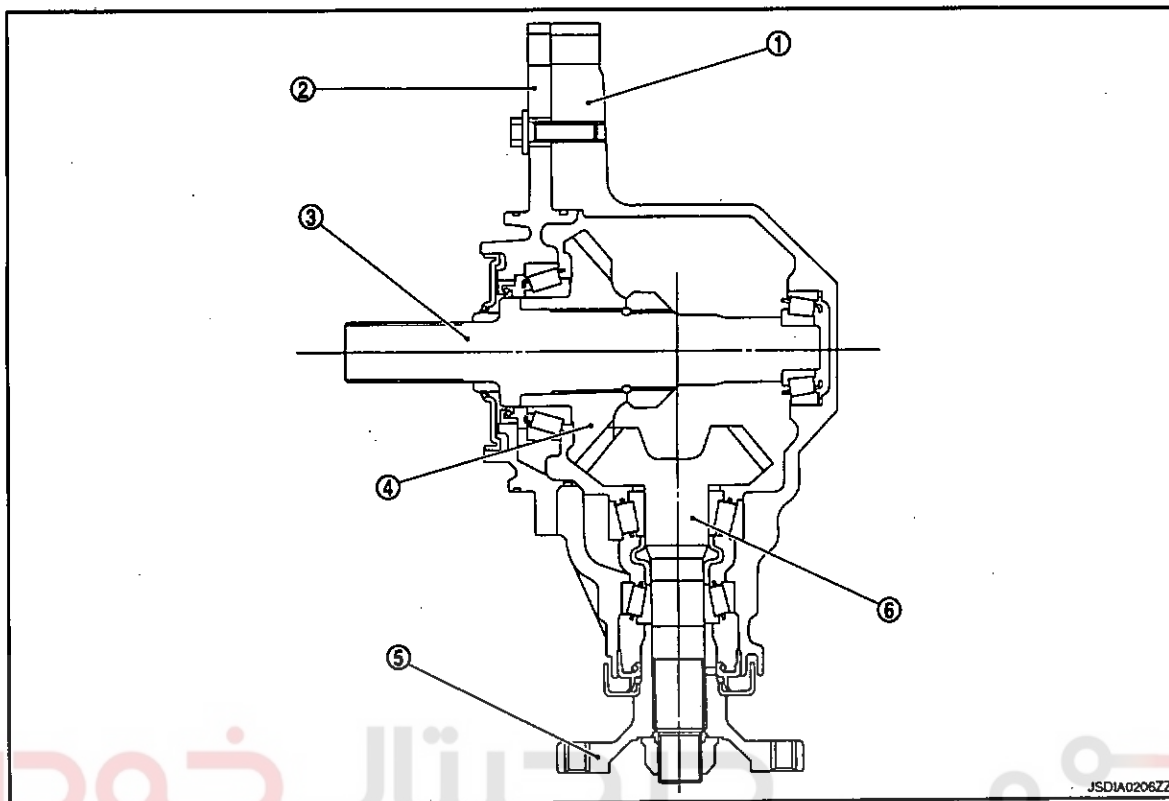

1. Transfer case

2. Adapter case

3. Ring gear shaft

4. Ring gear

5. Companion flange

6. Drive pinion

CROSS-SECTIONAL VIEW (CVT)

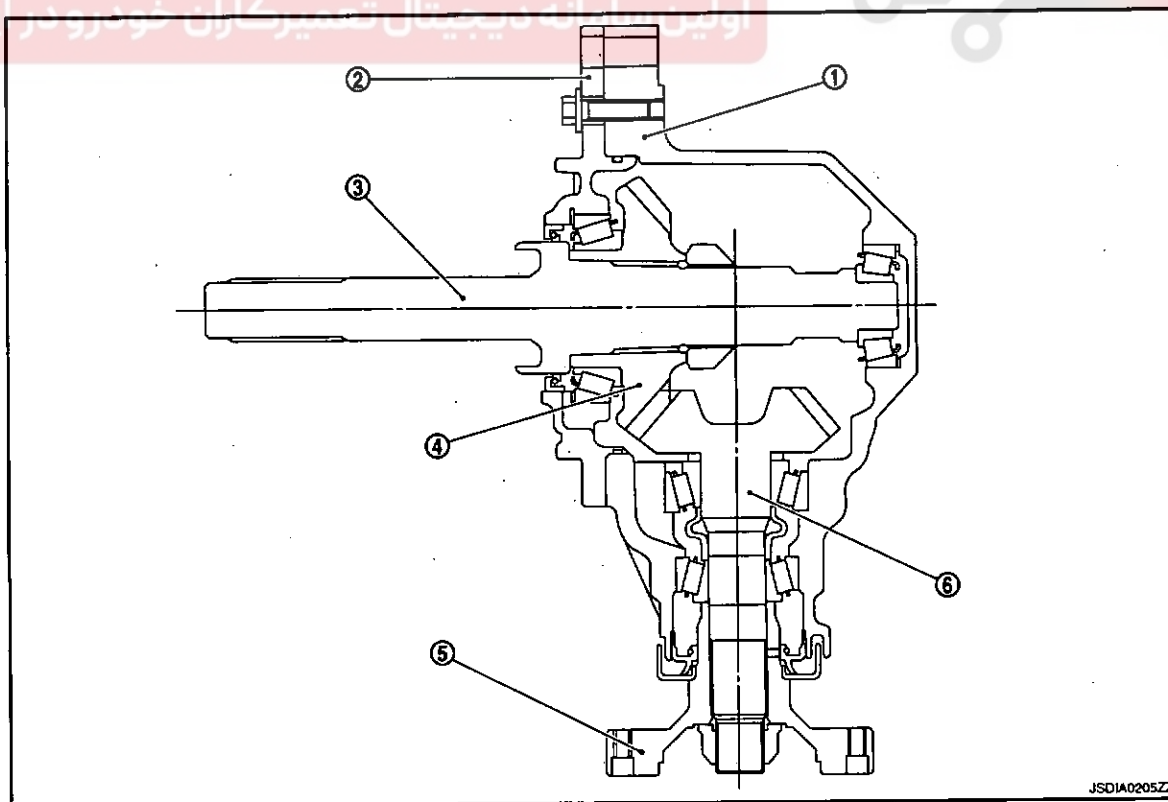

1. Transfer case

2. Adapter case

3. Ring gear shaft

4. Ring gear

5. Companion flange

6. Drive pinion

CROSS-SECTIONAL VIEW (CVT)

A
B
C
DLN
E
F
G
H
I
J
K
L
M
N
O
P

4WD SYSTEM

< FUNCTION DIAGNOSIS >

[TRANSFER: TY30A]

- | | | |
|------------------|---------------------|--------------------|
| 1. Transfer case | 2. Adapter case | 3. Ring gear shaft |
| 4. Ring gear | 5. Companion flange | 6. Drive pinion |

System Description

INFOID:000000004905365

DESCRIPTION

- 4WD controls distribution of drive power between front-wheel drive (100:0) and 4WD (50:50) conditions according to signals from sensors.
- It transmits/receives each signal from the following control unit via CAN communication line.

Component parts	Function
ABS actuator and electric unit (control unit)	Transmits the following signals via CAN communication to 4WD control unit. <ul style="list-style-type: none"> • Vehicle speed signal • Stop lamp switch signal (brake signal)
ECM	Transmits the following signals via CAN communication to 4WD control unit. <ul style="list-style-type: none"> • Accelerator pedal position signal • Engine speed signal
Combination meter	Transmits conditions of parking brake switch signal via CAN communication to 4WD control unit.
Steering angle sensor*	Transmits conditions of steering angle sensor signal via CAN communication to 4WD control unit.

*: With VDC

AUTO Mode

- Electronic control allows optimal distribution of torque to front/rear wheels to match road conditions.
- 4WD mode makes possible stable driving, with no wheel spin, on snowy roads or other slippery surfaces.
- On roads which do not require 4WD, AUTO mode contributes to improved fuel economy by driving in conditions close to front-wheel drive.
- Sensor inputs determine the vehicle's turning condition, and tight cornering/braking are controlled by distributing optimum torque to rear wheels.

LOCK Mode

- Front/rear wheel torque distribution is fixed, ensuring stable driving when climbing slopes.
- Vehicle will switch automatically to AUTO mode if vehicle speed increases. If vehicle speed then decreases, the vehicle automatically returns to direct 4-wheel driving conditions.
- LOCK mode will change to AUTO mode automatically, when the vehicle speed exceeds approx. 40 km/h (25 MPH). The LOCK indicator light keeps illuminating.

NOTE:

If there is a significant difference in pressure or wear between tires, full vehicle performance is not available. LOCK mode may be prohibited, or speeds at which LOCK mode is enabled may be restricted detecting tire conditions.

2WD Mode

Vehicle is in front-wheel drive.

NOTE:

- If front wheels are slipping in 2WD mode, do not switch to AUTO or LOCK. This can cause difficulties for the system.
- Even if the 4WD mode switch is in 2WD mode, the 4WD control unit occasionally automatically change to AUTO mode depending on the driving condition (For example; Depressing the acceleration firmly). This is not malfunction. However, 4WD indicator lamp dose not illuminate.

POWER TRANSFER DIAGRAM

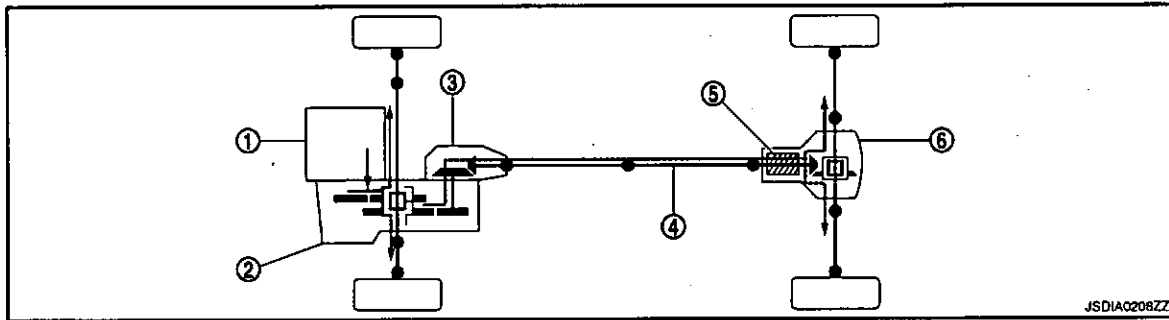

- | | | |
|--------------------|---------------------------------|---------------------|
| 1. Engine | 2. Transaxle | 3. Transfer |
| 4. Propeller shaft | 5. Electric controlled coupling | 6. Rear final drive |

OPERATION PRINCIPLE

Electric Controlled Coupling

1. The 4WD control unit supplies command current to electric controlled coupling (4WD solenoid).
2. The control clutch is engaged by electromagnet and torque is detected in control clutch.
3. The cam operates in response to control clutch torque and applies pressure to main clutch.
4. The main clutch transmits torque to front wheels according to pressing power.

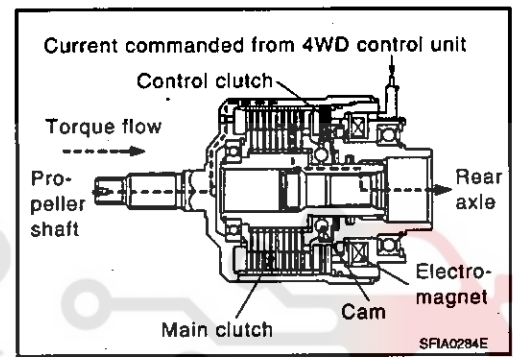

شرکت دیجیتال خودرو سامانه (مسئولیت محدود)
اولین سامانه دیجیتال تعمیرکاران خودرو در ایران

- Transmission torque to the rear wheels is determined according to command current.

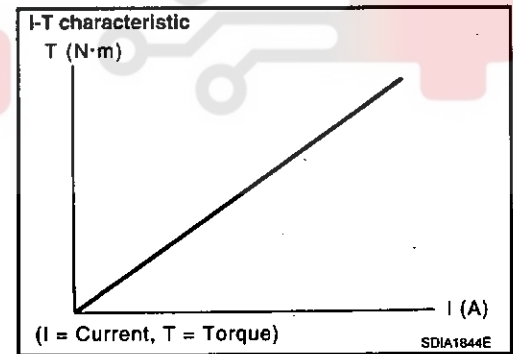

Component Parts Location

LHD MODELS

INFOID:000000004905366

4WD SYSTEM

< FUNCTION DIAGNOSIS >

[TRANSFER: TY30A]

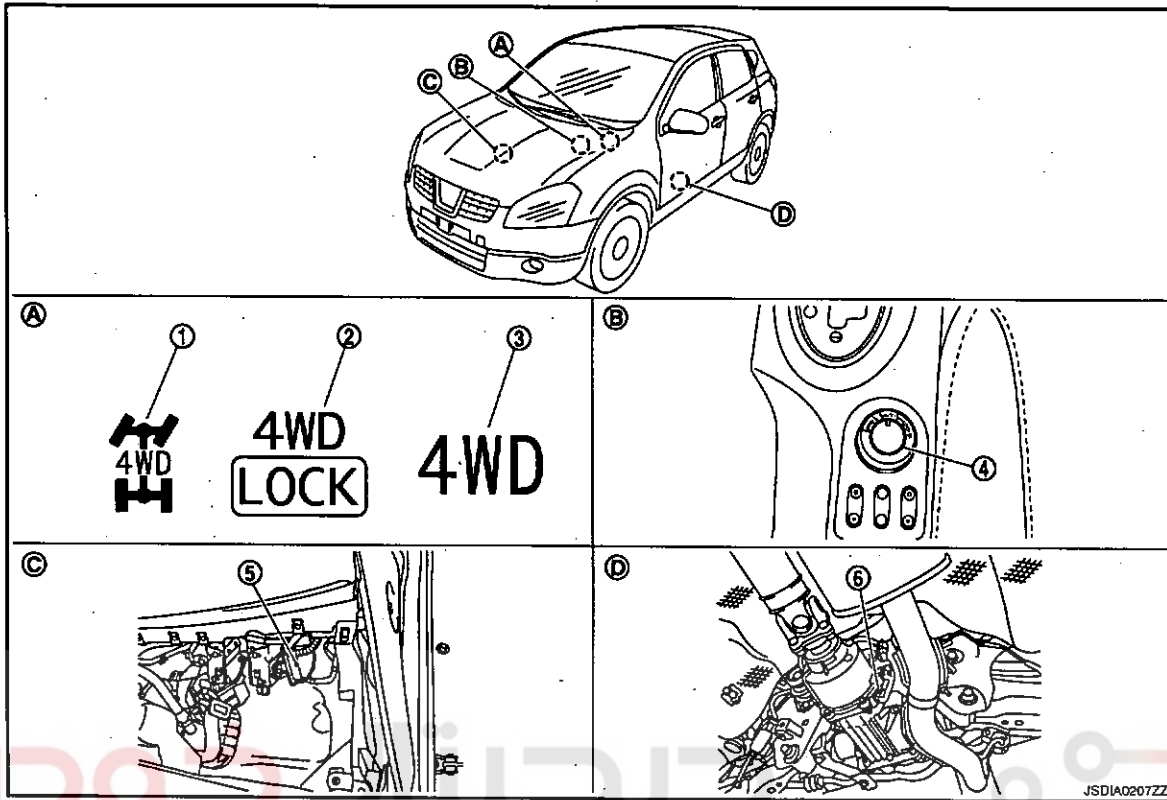

- 1. 4WD indicator lamp
- 2. LOCK indicator lamp
- 3. 4WD warning lamp
- 4. 4WD mode switch
- 5. 4WD control unit
- 6. 4WD solenoid (in rear final drive)
- A. Combination meter
- B. Center console assembly
- C. Glove box cover assembly removed
- D. Rear final drive assembly

RHD MODELS

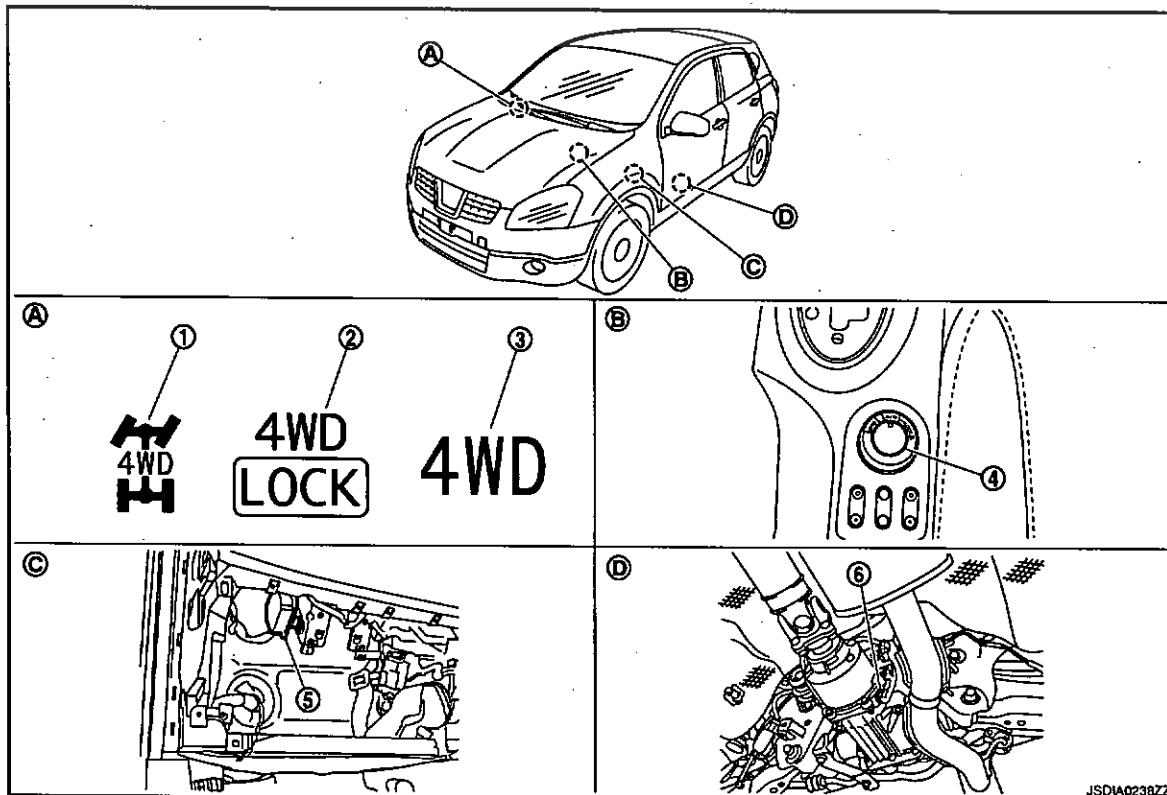

4WD SYSTEM

< FUNCTION DIAGNOSIS >

[TRANSFER: TY30A]

- | | | | |
|------------------------------|----------------------------|---------------------------------------|---|
| 1. 4WD indicator lamp | 2. LOCK indicator lamp | 3. 4WD warning lamp | A |
| 4. 4WD mode switch | 5. 4WD control unit | 6. 4WD solenoid (in rear final drive) | B |
| A. Combination meter | B. Center console assembly | C. Glove box cover assembly removed | C |
| D. Rear final drive assembly | | | |

Component Description

INFOID:000000004905367

Component parts	Reference/Function
4WD control unit	DLN-10. "Description"
Wheel sensors	BRC-14. "Description"
4WD solenoid	DLN-12. "Description"
Electric controlled coupling	Transmits driving force to rear final drive.
4WD warning lamp	DLN-24. "Description"
4WD indicator lamp	DLN-25. "Description"
LOCK indicator lamp	DLN-26. "Description"
4WD mode switch	DLN-16. "Description"
ABS actuator and electric unit (control unit)	DLN-11. "Description"
ECM	DLN-19. "Description"
Combination meter	DLN-25. "Description"

دیجیتال خودرو

شرکت دیجیتال خودرو سامانه (مسئولیت محدود)

اولین سامانه دیجیتال تعمیرکاران خودرو در ایران

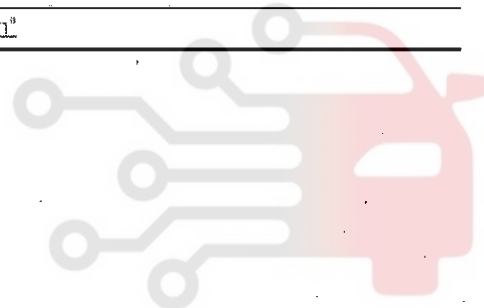

COMPONENT DIAGNOSIS

C1201 4WD CONTROL UNIT

Description

INFOID:000000004905369

- Controls driving force distribution by signals from each sensor from front wheel driving mode (100:0) to 4WD mode (50:50).
- 2WD mode is available by fail-safe function if malfunction is detected in 4WD system.

دیجیتال خودرو

شرکت دیجیتال خودرو سامانه (مسئولیت محدود)

اولین سامانه دیجیتال تعمیرکاران خودرو در ایران

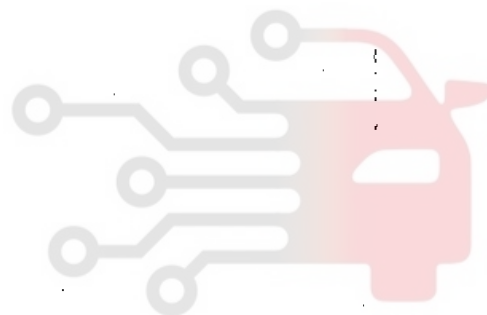

C1203 ABS ACTUATOR AND ELECTRIC UNIT (CONTROL UNIT)

Description

INFOID:000000004905372

Transmits the following signals via CAN communication to 4WD control unit.

- Vehicle speed signal
- Stop lamp switch signal (brake signal)

A

B

C

DLN

E

F

G

H

I

J

K

L

M

N

O

P

دیجیتال خودرو

شرکت دیجیتال خودرو سامانه (مسئولیت محدود)

اولین سامانه دیجیتال تعمیرکاران خودرو در ایران



C1204 4WD SOLENOID

Description

INFOID:000000004905375

Controls electric controlled coupling by command current from 4WD control unit.

Diagnosis Procedure

INFOID:000000004905377

1. CHECK 4WD SOLENOID POWER SUPPLY

1. Turn the ignition switch OFF.
2. Disconnect 4WD control unit harness connector.
3. Turn the ignition switch ON.

CAUTION:

Never start the engine.

4. Check the voltage between 4WD control unit harness connector and ground.

4WD control unit		Ground	Voltage (Approx.)
Connector	Terminal		
M69	9	Ground	Battery voltage

Is the inspection result normal?

YES >> GO TO 2.

NO >> Check the following. If any items are damaged, repair or replace damaged parts.

- 10A fuse (#32) open
- Short among 10A fuse (#32) connector, 4WD control unit harness connector No. 9 terminal and the ground
- Open between the battery and 4WD control unit harness connector No. 9 terminal

2. CHECK 4WD SOLENOID GROUND

1. Turn the ignition switch OFF.
2. Check the continuity between 4WD control unit harness connector and ground.

4WD control unit		Ground	Continuity
Connector	Terminal		
M69	10	Ground	Existed
	11		

Is the inspection result normal?

YES >> GO TO 3.

NO >> Repair or replace damaged parts.

3. CHECK 4WD SOLENOID CIRCUIT (1)

Check the resistance between 4WD control unit harness connector terminals.

4WD control unit			Resistance (Approx.)
Connector	Terminal		
M69	1	2	2.45 Ω

Is the inspection result normal?

YES >> GO TO 5.

NO >> GO TO 4.

4. CHECK 4WD SOLENOID CIRCUIT (2)

1. Disconnect 4WD solenoid harness connector.
2. Check the continuity between 4WD control unit harness connector and 4WD solenoid harness connector.

C1204 4WD SOLENOID

< COMPONENT DIAGNOSIS >

[TRANSFER: TY30A]

4WD control unit		4WD solenoid		Continuity
Connector	Terminal	Connector	Terminal	
M69	1	B251	1	Existed
	2		2	

3. Check the continuity between 4WD control unit harness connector and the ground.

4WD control unit		Ground	Continuity
Connector	Terminal		
M69	1	Ground	Not existed
	2		

4. Check the continuity between 4WD solenoid harness connector and the ground.

4WD solenoid		Ground	Continuity
Connector	Terminal		
B251	1	Ground	Not existed
	2		

Is the inspection result normal?

YES >> GO TO 5.

NO >> Repair or replace damaged parts.

5. CHECK 4WD SOLENOID

Check the resistance between 4WD solenoid harness connector terminals.

4WD solenoid			Resistance (Approx.)
Connector	Terminal		
B251	1	2	2.45 Ω

Is the inspection result normal?

YES >> GO TO 6.

NO >> 4WD solenoid is malfunctioning. Replace electric controlled coupling. Refer to DLN-126, "Exploded View".

6. CHECK TERMINALS AND HARNESS CONNECTORS

1. Check 4WD control unit pin terminals for damage or loose connection with harness connector.
2. Check 4WD solenoid pin terminals for damage or loose connection with harness connector.

Is the inspection result normal?

YES >> Replace 4WD control unit. Refer to DLN-50, "LHD : Exploded View" (LHD models), DLN-51, "RHD : Exploded View" (RHD models).

NO >> Repair or replace damaged parts.

Component Inspection

INFOID:000000004905378

1. CHECK 4WD SOLENOID

1. Turn the ignition switch OFF.
2. Disconnect 4WD solenoid harness connector.
3. Check the resistance between 4WD solenoid harness connector terminals.

4WD solenoid			Resistance (Approx.)
Connector	Terminal		
B251	1	2	2.45 Ω

Is the inspection result normal?

C1204 4WD SOLENOID

< COMPONENT DIAGNOSIS >

[TRANSFER: TY30A]

YES >> INSPECTION END

NO >> 4WD solenoid is malfunctioning. Replace electric controlled coupling. Refer to DLN-126,
"Exploded View".

دیجیتال خودرو

شرکت دیجیتال خودرو سامانه (مسئولیت محدود)

اولین سامانه دیجیتال تعمیرکاران خودرو در ایران

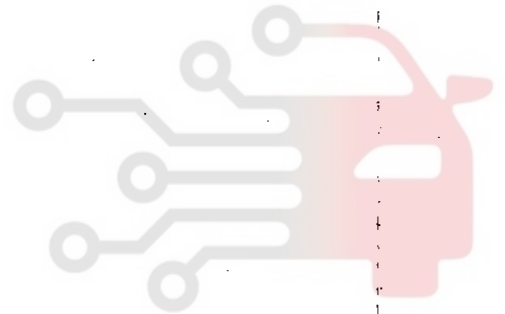

C1205 4WD ACTUATOR RELAY

Description

INFOID:000000004905379

4WD solenoid is supplied with voltage by the internal circuit of 4WD control unit.

A
B
C
DLN
E
F
G
H
I
J
K
L
M
N
O
P

دیجیتال خودرو

شرکت دیجیتال خودرو سامانه (مسئولیت محدود)

اولین سامانه دیجیتال تعمیرکاران خودرو در ایران



C1209 MODE SW

Description

INFOID:000000004905382

Able to select 2WD, AUTO or LOCK mode.

Diagnosis Procedure

INFOID:000000004905384

1. CHECK 4WD MODE SWITCH

1. Turn the ignition switch OFF.
2. Remove 4WD mode switch.
3. Check the continuity between 4WD mode switch connector terminals.

4WD mode switch			Continuity	
Connector	Terminal			
M8	2	3	4WD mode switch: 2WD	Existed
			Except the above	Not existed
	2	6	4WD mode switch: 2WD	Not existed
			4WD mode switch: AUTO	Existed
			4WD mode switch: LOCK (State of hold of LOCK position)	
	2	8	4WD mode switch: LOCK (State of hold of LOCK position)	Existed
Except the above			Not existed	

Is the inspection result normal?

- YES >> GO TO 2. شرکت دیجیتال خودرو سامانه (م)
- NO >> Replace 4WD mode switch.

2. CHECK 4WD MODE SWITCH CIRCUIT (1)

Check the continuity between 4WD mode switch harness connector and ground.

4WD mode switch		Ground	Continuity
Connector	Terminal		
M8	2	Ground	Existed

Is the inspection result normal?

- YES >> GO TO 3.
- NO >> Repair or replace damaged parts.

3. CHECK 4WD MODE SWITCH CIRCUIT (2)

1. Disconnect 4WD control unit harness connector.
2. Check the continuity between 4WD control unit harness connector and 4WD mode switch harness connector.

4WD control unit		4WD mode switch		Continuity
Connector	Terminal	Connector	Terminal	
M69	14	M8	3	Not existed
	14		6	Not existed
	14		8	Existed
	5		3	Not existed
	5		6	Existed
	5		8	Not existed
	12		3	Existed
	12		6	Not existed
	12	8	Not existed	

3. Check the continuity between 4WD control unit harness connector and ground.

4WD control unit		Ground	Continuity
Connector	Terminal		
M69	14	Ground	Not existed
	5		
	12		

Is the inspection result normal?

YES >> GO TO 4.

NO >> Repair or replace damaged parts.

4. CHECK 4WD CONTROL UNIT OUTPUT SIGNAL

1. Connect 4WD control unit harness connector.
2. Turn the ignition switch ON.
3. Check the voltage between 4WD mode switch harness connector and ground.

4WD mode switch		Ground	Voltage (Approx.)
Connector	Terminal		
M8	3	Ground	Battery voltage
	6		
	8		

Is the inspection result normal?

YES >> Check each harness connector pin terminal for disconnection.

NO >> Replace 4WD control unit. Refer to DLN-50, "LHD : Exploded View" (LHD models), DLN-51, "RHD : Exploded View" (RHD models).

Component Inspection

INFOID:000000004905385

1. CHECK 4WD MODE SWITCH

1. Turn the ignition switch OFF.
2. Remove 4WD mode switch.
3. Check the continuity between 4WD mode switch connector terminals.

C1209 MODE SW

< COMPONENT DIAGNOSIS >

[TRANSFER: TY30A]

4WD mode switch			Continuity	
Connector	Terminal			Condition
M8	2	3	4WD mode switch: 2WD	Existed
			Except the above	Not existed
	2	6	4WD mode switch: 2WD	Not existed
			4WD mode switch: AUTO	Existed
			4WD mode switch: LOCK (State of hold of LOCK position)	
	2	8	4WD mode switch: LOCK (State of hold of LOCK position)	Existed
Except the above			Not existed	

Is the inspection result normal?

YES >> INSPECTION END

NO >> Replace 4WD mode switch.

دیجیتال خودرو

شرکت دیجیتال خودرو سامانه (مسئولیت محدود)

اولین سامانه دیجیتال تعمیرکاران خودرو در ایران



C1210 ECM

Description

INFOID:000000004905386

Transmits the following signals via CAN communication to 4WD control unit.

- Accelerator pedal position signal
- Engine speed signal

A

B

C

DLN

E

F

G

H

I

J

K

L

M

N

O

P

دیجیتال خودرو

شرکت دیجیتال خودرو سامانه (مسئولیت محدود)

اولین سامانه دیجیتال تعمیرکاران خودرو در ایران



U1000 CAN COMM CIRCUIT

< COMPONENT DIAGNOSIS >

[TRANSFER: TY30A]

U1000 CAN COMM CIRCUIT

Description

INFOID:000000004905389

CAN (Controller Area Network) is a serial communication line for real time application. It is an on-vehicle multiplex communication line with high data communication speed and excellent error detection ability. Many electronic control units are equipped onto a vehicle, and each control unit shares information and links with other control units during operation (not independent). In CAN communication, control units are connected with 2 communication lines (CAN-H line, CAN-L line) allowing a high rate of information transmission with less wiring. Each control unit transmits/receives data but selectively reads required data only.

دیجیتال خودرو

شرکت دیجیتال خودرو سامانه (مسئولیت محدود)

اولین سامانه دیجیتال تعمیرکاران خودرو در ایران



U1010 CONTROL UNIT (CAN)

< COMPONENT DIAGNOSIS >

[TRANSFER: TY30A]

U1010 CONTROL UNIT (CAN)

Description

INFOID:000000004905392

CAN (Controller Area Network) is a serial communication line for real time application. It is an on-vehicle multiplex communication line with high data communication speed and excellent error detection ability. Many electronic control units are equipped onto a vehicle, and each control unit shares information and links with other control units during operation (not independent). In CAN communication, control units are connected with 2 communication lines (CAN-H line, CAN-L line) allowing a high rate of information transmission with less wiring. Each control unit transmits/receives data but selectively reads required data only.

Diagnosis Procedure

INFOID:000000004905394

DLN

1. CHECK 4WD CONTROL UNIT

Check 4WD control unit harness connector for disconnection and deformation.

Is the inspection result normal?

- YES >> Replace 4WD control unit. Refer to [DLN-50](#). "LHD : Exploded View" (LHD models), [DLN-51](#). "RHD : Exploded View" (RHD models).
- NO >> Repair or replace damaged parts.

دیجیتال خودرو

شرکت دیجیتال خودرو سامانه (مسئولیت محدود)

اولین سامانه دیجیتال تعمیرکاران خودرو در ایران



POWER SUPPLY AND GROUND CIRCUIT

Description

INFOID:000000004905395

Supplies power to 4WD control unit.

Diagnosis Procedure

INFOID:000000004905396

1. CHECK 4WD CONTROL UNIT POWER SUPPLY

1. Turn the ignition switch OFF.
2. Disconnect 4WD control unit harness connector.
3. Check the voltage between 4WD control unit harness connector and ground.

4WD control unit		Ground	Voltage (Approx.)
Connector	Terminal		
M69	7	Ground	0 V

4. Turn the ignition switch ON.
CAUTION:
Never start the engine.
5. Check the voltage between 4WD control unit harness connector and ground.

4WD control unit		Ground	Voltage (Approx.)
Connector	Terminal		
M69	7	Ground	Battery voltage

Is the inspection result normal?

- YES >> GO TO 2.
 NO >> Check the following. If any items are damaged, repair or replace damaged parts.
- 10A fuse (#59) open
 - Short among 10A fuse (#59) connector, 4WD control unit harness connector No. 7 terminal and the ground
 - Open between the ignition switch and 4WD control unit harness connector No. 7 terminal
 - Ignition switch. Refer to DLK-70, "Diagnosis Procedure" (With Intelligent Key system), DLK-284, "Diagnosis Procedure" (Without Intelligent Key system).

2. CHECK 4WD SOLENOID POWER SUPPLY

1. Turn the ignition switch OFF.
2. Check the voltage between 4WD control unit harness connector and ground.

4WD control unit		Ground	Voltage (Approx.)
Connector	Terminal		
M69	9	Ground	Battery voltage

3. Turn the ignition switch ON.
CAUTION:
Never start the engine.
4. Check the voltage between 4WD control unit harness connector and ground.

4WD control unit		Ground	Voltage (Approx.)
Connector	Terminal		
M69	9	Ground	Battery voltage

Is the inspection result normal?

- YES >> GO TO 3.
 NO >> Check the following. If any items are damaged, repair or replace damaged parts.
- 10A fuse (#32) open

POWER SUPPLY AND GROUND CIRCUIT

< COMPONENT DIAGNOSIS >

[TRANSFER: TY30A]

- Short among 10A fuse (#32) connector, 4WD control unit harness connector No. 9 terminal and the ground
- Open between the battery and 4WD control unit harness connector No. 9 terminal

3. CHECK 4WD SOLENOID VALVE GROUND

1. Turn the ignition switch OFF.
2. Check the continuity between 4WD control unit harness connector and ground.

4WD control unit		Ground	Continuity
Connector	Terminal		
M69	10	Ground	Existed
	11		

Is the inspection result normal?

- YES >> INSPECTION END.
NO >> Repair or replace damaged parts.

دیجیتال خودرو

شرکت دیجیتال خودرو سامانه (مسئولیت محدود)

اولین سامانه دیجیتال تعمیرکاران خودرو در ایران



A
B
C
DLN
E
F
G
H
I
J
K
L
M
N
O
P

4WD WARNING LAMP

< COMPONENT DIAGNOSIS >

[TRANSFER: TY30A]

4WD WARNING LAMP

Description

INFOID:000000004905397

- Turns ON when there is a malfunction in 4WD system. It indicates that fail-safe mode is engaged and vehicle change to front-wheel drive or shifting driving force-4WD (rear wheels still have some driving torque).
- Also turns ON when ignition switch is turned ON, for purpose of lamp check. Turns OFF after the engine starts if system is normal.

4WD WARNING LAMP INDICATION

Condition	4WD warning lamp
Lamp check	Turns ON when ignition switch is turned ON. Turns OFF after engine start.
4WD system malfunction	ON
Protection function is activated due to heavy load to electric controlled coupling. (4WD system is not malfunctioning and 4WD system changes to 2WD mode.)	Quick blinking: 2 times/second (Blinking in approx. 1 minute and then turning OFF)
Large difference in diameter of front/rear tires	Slow blinking: 1 time/2 seconds (Continuing to blink until turning ignition switch OFF)
Other than above (system normal)	OFF

CAUTION:

4WD warning lamp also turns ON due to data reception error, CAN communication error etc.

دیجیتال خودرو

شرکت دیجیتال خودرو سامانه (مسئولیت محدود)

اولین سامانه دیجیتال تعمیرکاران خودرو در ایران

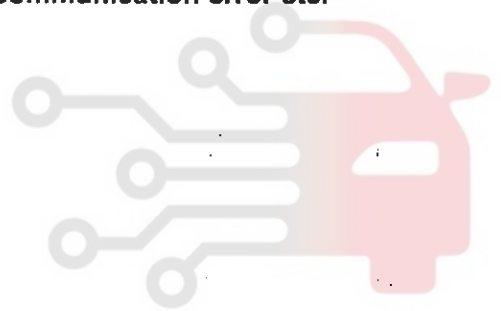

4WD INDICATOR LAMP

Description

INFOID:000000004905399

The following is the indications of indicator lamp after engine start.

4WD INDICATOR LAMP AND LOCK INDICATOR LAMP

Condition	4WD indicator lamp	LOCK indicator lamp
2WD mode	OFF	OFF
AUTO mode	ON	OFF
LOCK mode	ON	ON

دیجیتال خودرو

شرکت دیجیتال خودرو سامانه (مسئولیت محدود)

اولین سامانه دیجیتال تعمیرکاران خودرو در ایران



LOCK INDICATOR LAMP

< COMPONENT DIAGNOSIS >

[TRANSFER: TY30A]

LOCK INDICATOR LAMP

Description

INFOID:000000004905401

The following is the indications of indicator lamp after engine start.

4WD INDICATOR LAMP AND LOCK INDICATOR LAMP

Condition	4WD indicator lamp	LOCK indicator lamp
2WD mode	OFF	OFF
AUTO mode	ON	OFF
LOCK mode	ON	ON

دیجیتال خودرو

شرکت دیجیتال خودرو سامانه (مسئولیت محدود)

اولین سامانه دیجیتال تعمیرکاران خودرو در ایران

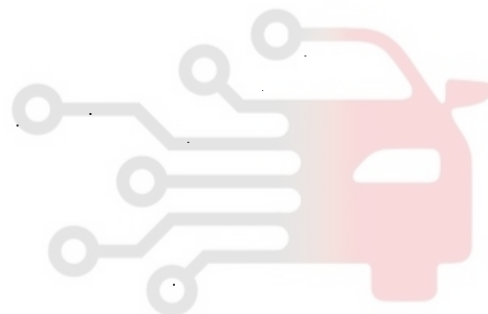

4WD CONTROL UNIT

< ECU DIAGNOSIS >

[TRANSFER: TY30A]

ECU DIAGNOSIS

4WD CONTROL UNIT

Reference Value

INFOID:000000004905403

TERMINAL LAYOUT

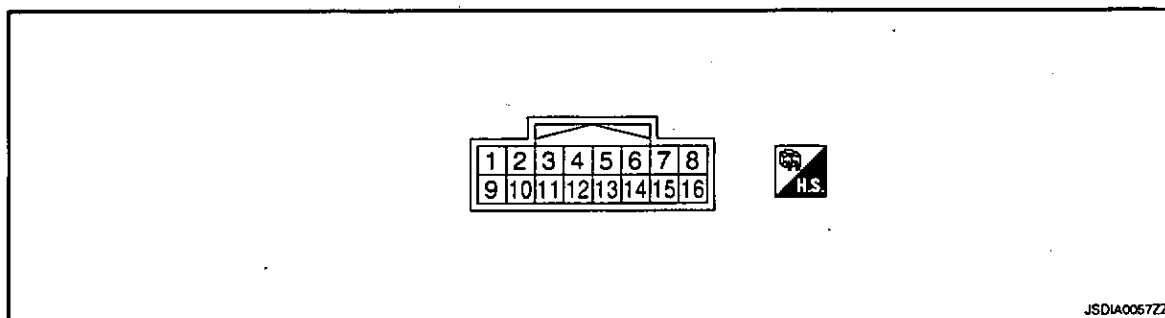

PHYSICAL VALUES

Terminal No. (Wire color)	Description		Condition	Value (Approx.)		
+	-	Signal name	Input/ Output			
1 (LG)	Ground	4WD solenoid power supply	Output	4WD mode switch: 2WD	0 V	
				Engine speed: At idle	4WD indicator lamp: ON	0 V
					LOCK indicator lamp: ON	0 V
				Engine speed: 3,000 rpm or more constant	4WD mode switch: 2WD	0 V
					4WD indicator lamp: ON	2.5 V*
		LOCK indicator lamp: ON	8 V			
2 (L)	Ground	4WD solenoid ground	-	Engine speed: At idle	0 V	
				Engine speed: 3,000 rpm or more constant	0 V	
5 (V)	Ground	4WD mode switch (AUTO)	Output	Ignition switch: ON	4WD mode switch: 2WD	Battery voltage
					4WD mode switch: AUTO	0 V
					4WD mode switch: LOCK (State of hold of LOCK position)	0 V
7 (P)	Ground	Ignition switch	Input	Ignition switch: ON	Battery voltage	
				Ignition switch: OFF	0 V	
8 (L)	-	CAN-H	Input/ Output	-	-	
9 (G)	Ground	Power supply (4WD solenoid)	Input	Ignition switch: ON	Battery voltage	
				Ignition switch: OFF	Battery voltage	
10 (B)	Ground	Ground	-	Always	0 V	
11 (B)	Ground	Ground	-	Always	0 V	
12 (BR)	Ground	4WD mode switch (2WD)	Output	Ignition switch: ON	4WD mode switch: 2WD	0 V
					4WD mode switch: AUTO	Battery voltage
					4WD mode switch: LOCK (State of hold of LOCK position)	Battery voltage

4WD CONTROL UNIT

< ECU DIAGNOSIS >

[TRANSFER: TY30A]

Terminal No. (Wire color)		Description		Condition	Value (Approx.)
+	-	Signal name	Input/ Output		
14 (Y)	Ground	4WD mode switch (LOCK)	Output	4WD mode switch: 2WD	Battery voltage
				4WD mode switch: AUTO	Battery voltage
				4WD mode switch: LOCK (State of hold of LOCK position)	0 V
16 (P)	—	CAN-L	Input/ Output	—	—

*: The values are changed by throttle opening and engine speed.

CAUTION:

When using circuit tester to measure voltage for inspection, be sure not to extend forcibly any connector terminals.

دیجیتال خودرو

شرکت دیجیتال خودرو سامانه (مسئولیت محدود)

اولین سامانه دیجیتال تعمیرکاران خودرو در ایران

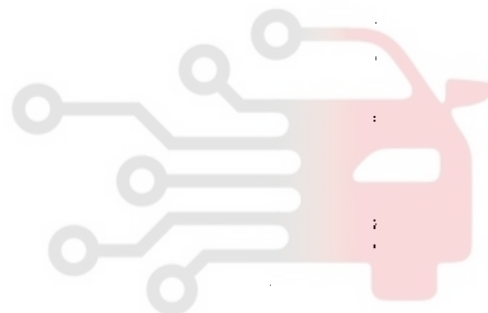

4WD CONTROL UNIT

[TRANSFER: TY30A]

< ECU DIAGNOSIS >

Wiring Diagram - 4WD SYSTEM -

INFOID:000000004905404

- : With gasoline engine
- : With M9R engine
- : With VDC
- : Without VDC
- *1 64:
- 100:
- *2 83:
- 98:

Refer to the following.
 (M77) SUPER MULTIPLE JUNCTION (SMJ)
 (E16) (E17) - ELECTRICAL UNITS

4WD SYSTEM

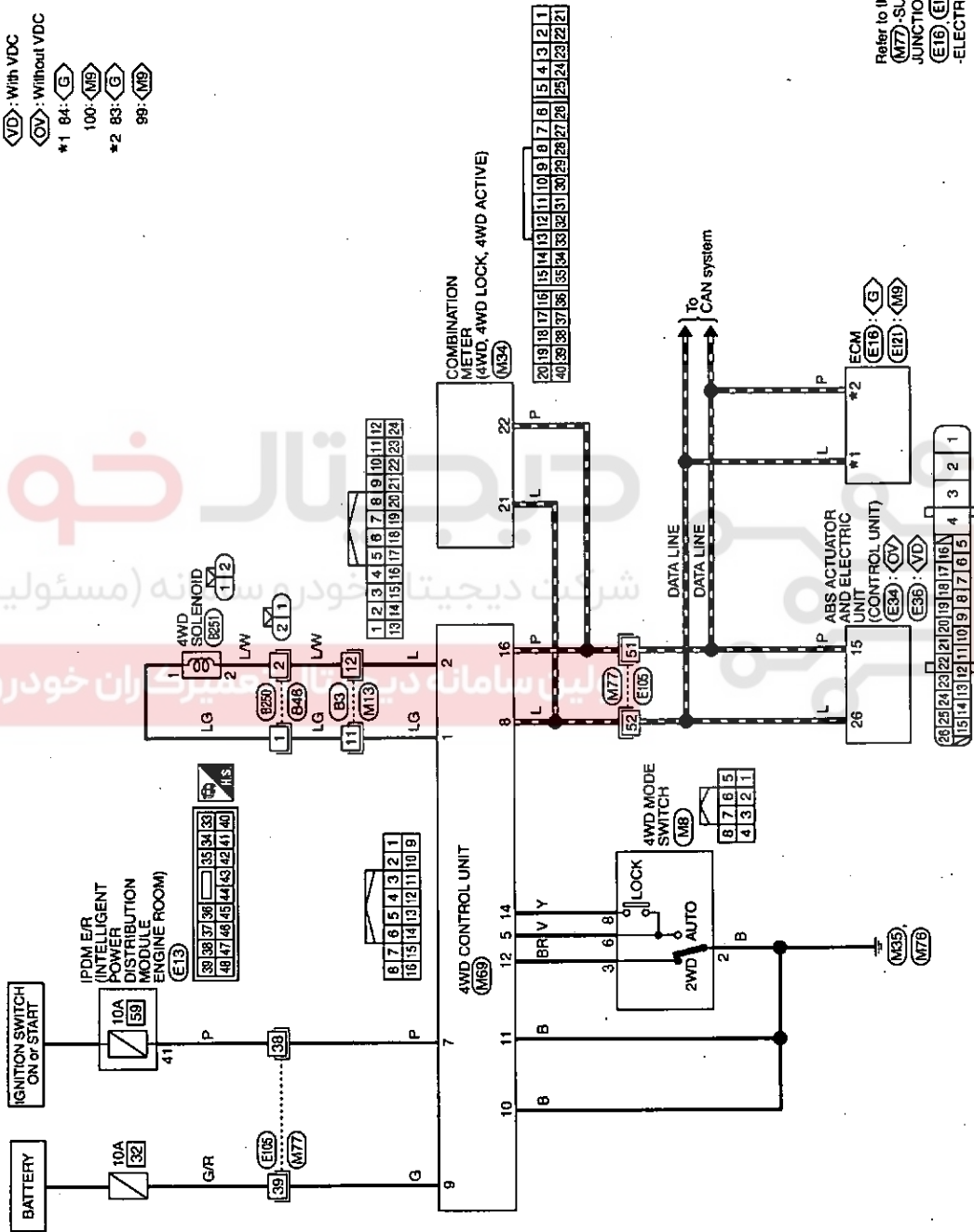

JMDWA0008G1

Fail Safe

INFOID:000000004905405

4WD system

- If any malfunction occurs in 4WD electrical system, and control unit detects the malfunction, 4WD warning lamp on combination meter turns ON to indicate system malfunction.

A
 B
 C
 DLN
 E
 F
 G
 H
 I
 J
 K
 L
 M
 N
 O
 P

4WD CONTROL UNIT

< ECU DIAGNOSIS >

[TRANSFER: TY30A]

- When 4WD warning lamp is ON, vehicle changes to front-wheel drive or shifting driving force-4WD (Rear wheels still have some driving torque).
- 4WD system activates its protection function (shuts down 4WD system temporarily) if 4WD system detects high load continuously or the front wheel tire size differs from the rear tire size. (4WD system is automatically restored if 4WD system no longer detects any overload or the tire size difference is eliminated.)

Mode	Warning lamp	DTC	Detected area (Error area)	Error area and root cause
Protection function	Blinking*1	—	4WD control unit	Transfer assembly in protection mode (Internal temperature rise of electronic controlled coupling)
	Blinking*2	—	4WD control unit	Malfunction in each tire or different tire diameter
Fail-safe	ON	C1201	4WD control unit	Internal malfunction of 4WD control unit
		C1203	ABS actuator and electric unit (control unit)	ABS malfunction <ul style="list-style-type: none"> • Vehicle speed signal error • Stop lamp switch signal (brake signal) error
		C1204	4WD solenoid	Internal malfunction of electronic controlled coupling
		C1205	4WD control unit	Internal malfunction of 4WD control unit
		C1209	4WD mode switch	Malfunction of 4WD mode switch or 4WD mode switch circuit
		C1210	ECM	Malfunction of engine control system <ul style="list-style-type: none"> • Accelerator pedal position signal error • Engine speed signal error
		U1000	CAN communication line	<ul style="list-style-type: none"> • CAN communication error • Malfunction of 4WD control unit
		U1010	4WD control unit	Malfunction of 4WD control unit

*1: Quick blinking: 2 times/second (blinking for approx. 1 minute and then turned OFF)

*2: Slow blinking: 1 time/2 seconds (Continuing to blink until ignition switch is turned OFF)

سركت ديگييال خودرو سامانه (مستوليت محدود)

اولين سامانه ديگييال تعميركاران خودرو در ايران

4WD SYSTEM SYMPTOMS

< SYMPTOM DIAGNOSIS >

[TRANSFER: TY30A]

SYMPTOM DIAGNOSIS

4WD SYSTEM SYMPTOMS

Symptom Table

INFOID:000000004905408

Symptom	Condition	Check item	Reference
4WD warning lamp does not turn ON when the ignition switch is turned to ON. (4WD warning lamp check)	Ignition switch: ON	Power supply and ground for 4WD control unit	DLN-32, "Description"
		CAN communication line	
		4WD control unit	
		Combination meter	
4WD warning lamp does not turn OFF several seconds after engine started.	Engine running	4WD control unit	DLN-33, "Description"
		4WD warning lamp	
		Power supply and ground for 4WD control unit	
Heavy tight-corner braking symptom occurs when the vehicle is driven and the steering wheel is turned fully to either side after the engine is started. (See NOTE.)	<ul style="list-style-type: none"> While driving Steering wheel is turned fully to either sides 	ECM	DLN-34, "Description"
		4WD control unit	
		4WD solenoid	
		Mechanical malfunction of electric controlled coupling (clutch sticking etc.)	
Vehicle does not enter 4WD mode even though 4WD warning lamp turned to OFF.	While driving	CAN communication line	DLN-35, "Description"
		4WD solenoid	
		Mechanical malfunction of electric controlled coupling (Mechanical engagement of clutch is not possible.)	
While driving, 4WD warning lamp blinks quickly. (When blinking in approx. 1 minute and then turning OFF.) Quick blinking: 2 times/second	While driving	Protection function is activated due to heavy load to electric controlled coupling. (4WD system is not malfunctioning. Also, optional distribution of torque sometimes becomes rigid before lamp blinks quickly, but it is not malfunction.)	DLN-36, "Description"
While driving, 4WD warning lamp blinks slowly. (When continuing to blink until turning ignition switch OFF) Slow blinking: 1 time/2 seconds	<ul style="list-style-type: none"> While driving Vehicle speed: 20 km/h (12 MPH) or more 	Tire size is different between front and rear of vehicle.	DLN-37, "Description"

NOTE:

Light tight-corner braking symptom may occur depending on driving conditions. This is not malfunction.

4WD WARNING LAMP DOES NOT TURN ON

< SYMPTOM DIAGNOSIS >

[TRANSFER: TY30A]

4WD WARNING LAMP DOES NOT TURN ON

Description

INFOID:000000004905409

4WD warning lamp does not turn ON when the ignition switch is turned to ON.

دیجیتال خودرو

شرکت دیجیتال خودرو سامانه (مسئولیت محدود)

اولین سامانه دیجیتال تعمیرکاران خودرو در ایران

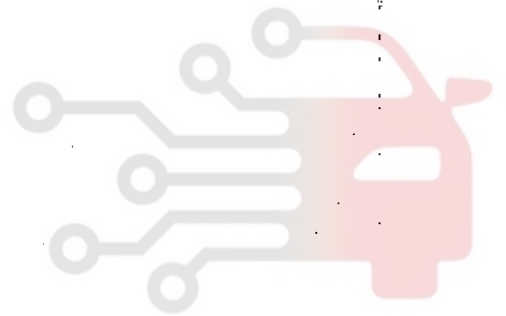

4WD WARNING LAMP DOES NOT TURN OFF

< SYMPTOM DIAGNOSIS >

[TRANSFER: TY30A]

4WD WARNING LAMP DOES NOT TURN OFF

Description

INFOID:000000004905411

4WD warning lamp does not turn OFF several seconds after engine started.

- A
- B
- C
- DLN
- E
- F
- G
- H
- I
- J
- K
- L
- M
- N
- O
- P

دیجیتال خودرو

شرکت دیجیتال خودرو سامانه (مسئولیت محدود)

اولین سامانه دیجیتال تعمیرکاران خودرو در ایران



HEAVY TIGHT-CORNER BRAKING SYMPTOM OCCURS

< SYMPTOM DIAGNOSIS >

[TRANSFER: TY30A]

HEAVY TIGHT-CORNER BRAKING SYMPTOM OCCURS

Description

INFOID:000000004905413

Heavy tight-corner braking symptom occurs when the vehicle is driven and the steering wheel is turned fully to either side after the engine is started.

NOTE:

Light tight-corner braking symptom may occur depending on driving conditions. This is not malfunction.

دیجیتال خودرو

شرکت دیجیتال خودرو سامانه (مسئولیت محدود)

اولین سامانه دیجیتال تعمیرکاران خودرو در ایران

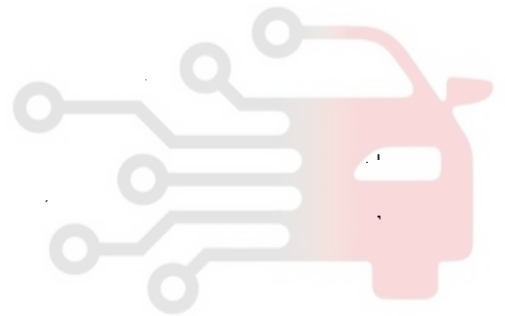

VEHICLE DOES NOT ENTER 4WD MODE

< SYMPTOM DIAGNOSIS >

[TRANSFER: TY30A]

VEHICLE DOES NOT ENTER 4WD MODE

Description

INFOID:000000004905415

Vehicle does not enter 4WD mode even though 4WD warning lamp turned to OFF.

- A
- B
- C
- DLN
- E
- F
- G
- H
- I
- J
- K
- L
- M
- N
- O
- P

دیجیتال خودرو

شرکت دیجیتال خودرو سامانه (مسئولیت محدود)

اولین سامانه دیجیتال تعمیرکاران خودرو در ایران



4WD WARNING LAMP BLINKS QUICKLY

< SYMPTOM DIAGNOSIS >

[TRANSFER: TY30A]

4WD WARNING LAMP BLINKS QUICKLY

Description

INFOID:000000004905417

While driving, 4WD warning lamp blinks 2 times in 1 second and it turns OFF after 1 minute.

- This symptom protects drive train parts when a heavy load is applied to the electric controlled coupling and multiple disc clutch temperature increases. Also, optional distribution of torque sometimes becomes rigid before lamp blinks quickly. Both cases are not malfunction.
- When this symptom occurs, stop vehicle and allow it to idle for some times. Blinking will stop and system will be restored.

دیجیتال خودرو

شرکت دیجیتال خودرو سامانه (مسئولیت محدود)

اولین سامانه دیجیتال تعمیرکاران خودرو در ایران

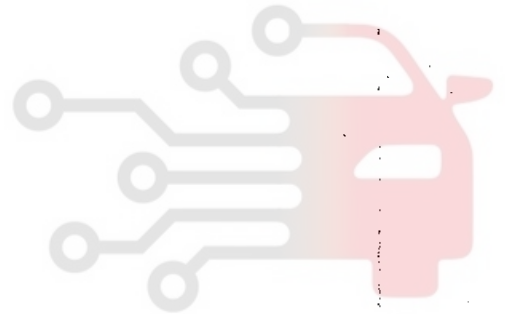

4WD WARNING LAMP BLINKS SLOWLY

< SYMPTOM DIAGNOSIS >

[TRANSFER: TY30A]

4WD WARNING LAMP BLINKS SLOWLY

Description

INFOID:000000004905418

4WD warning lamp blinks at approximately 2 seconds intervals while driving.

A
B
C
DLN
E
F
G
H
I
J
K
L
M
N
O
P

دیجیتال خودرو

شرکت دیجیتال خودرو سامانه (مسئولیت محدود)

اولین سامانه دیجیتال تعمیرکاران خودرو در ایران



NORMAL OPERATING CONDITION

< SYMPTOM DIAGNOSIS >

[TRANSFER: TY30A]

NORMAL OPERATING CONDITION

Description

INFOID:000000004905420

While driving, 4WD warning lamp blinks 2 times in 1 second and it turns OFF after 1 minute.

- This symptom protects drive train parts when a heavy load is applied to the electric controlled coupling and multiple disc clutch temperature increases. Also, optional distribution of torque sometimes becomes rigid before lamp blinks quickly. Both cases are not malfunction.
- When this symptom occurs, stop vehicle and allow it to idle for some times. Blinking will stop and system will be restored.

دیجیتال خودرو

شرکت دیجیتال خودرو سامانه (مسئولیت محدود)

اولین سامانه دیجیتال تعمیرکاران خودرو در ایران

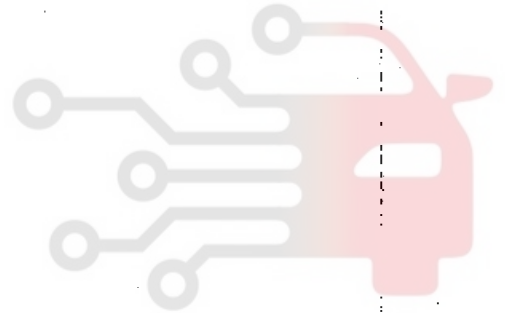

NOISE, VIBRATION AND HARSHNESS (NVH) TROUBLESHOOTING

< SYMPTOM DIAGNOSIS >

[TRANSFER: TY30A]

NOISE, VIBRATION AND HARSHNESS (NVH) TROUBLESHOOTING

NVH Troubleshooting Chart

INFOID:000000004905421

M/T MODELS

Use the chart below to help you find the cause of the symptom. The numbers indicate the order of the inspection. If necessary, repair or replace these parts.

Reference		DLN-49. "Inspection"			DLN-56. "M/T : Exploded View"		DLN-56. "M/T : Exploded View"		DLN-56. "M/T : Exploded View"		DLN-65. "M/T : Inspection After Disassembly"		DLN-65. "M/T : Inspection After Disassembly"	
SUSPECTED PARTS (Possible cause)		TRANSFER OIL (Level low)	TRANSFER OIL (Wrong)	TRANSFER OIL (Level too high)	LIQUID GASKET (Damaged)	O-RING (Worn or damaged)	OIL SEAL (Worn or damaged)	GEAR (Worn or damaged)	BEARING (Worn or damaged)					
Symptom	Noise	1	2				3	3	3					
	Transfer oil leakage		3	1	2	2	2							

CVT MODELS

Use the chart below to help you find the cause of the symptom. The numbers indicate the order of the inspection. If necessary, repair or replace these parts.

A
B
C
DLN
E
F
G
H
I
J
K
L
M
N
O
P

NOISE, VIBRATION AND HARSHNESS (NVH) TROUBLESHOOTING

< SYMPTOM DIAGNOSIS >

[TRANSFER: TY30A]

Symptom		SUSPECTED PARTS (Possible cause)								
		TRANSFER OIL (Level low)	TRANSFER OIL (Wrong)	TRANSFER OIL (Level too high)	LIQUID GASKET (Damaged)	O-RING (Worn or damaged)	OIL SEAL (Worn or damaged)	GEAR (Worn or damaged)	BEARING (Worn or damaged)	
Reference	Noise	1	2				3	3	3	
	Transfer oil leakage		3	1	2	2	2			
		DLN-49. "Inspection"			DLN-59. "CVT : Exploded View"		DLN-59. "CVT : Exploded View"		DLN-59. "CVT : Exploded View"	
					DLN-59. "CVT : Exploded View"		DLN-69. "CVT : Inspection After Disassembly"		DLN-69. "CVT : Inspection After Disassembly"	



اولین سامانه دیجیتال تعمیرکاران خودرو در ایران

PRECAUTIONS

< PRECAUTION >

[TRANSFER: TY30A]

PRECAUTION

PRECAUTIONS

Precaution for Supplemental Restraint System (SRS) "AIR BAG" and "SEAT BELT PRE-TENSIONER"

INFOID:000000005022500

The Supplemental Restraint System such as "AIR BAG" and "SEAT BELT PRE-TENSIONER", used along with a front seat belt, helps to reduce the risk or severity of injury to the driver and front passenger for certain types of collision. This system includes seat belt switch inputs and dual stage front air bag modules. The SRS system uses the seat belt switches to determine the front air bag deployment, and may only deploy one front air bag, depending on the severity of a collision and whether the front occupants are belted or unbelted. Information necessary to service the system safely is included in the "SRS AIR BAG" and "SEAT BELT" of this Service Manual.

WARNING:

- To avoid rendering the SRS inoperative, which could increase the risk of personal injury or death in the event of a collision which would result in air bag inflation, all maintenance must be performed by an authorized NISSAN/INFINITI dealer.
- Improper maintenance, including incorrect removal and installation of the SRS, can lead to personal injury caused by unintentional activation of the system. For removal of Spiral Cable and Air Bag Module, see the "SRS AIR BAG".
- Do not use electrical test equipment on any circuit related to the SRS unless instructed to in this Service Manual. SRS wiring harnesses can be identified by yellow and/or orange harnesses or harness connectors.

PRECAUTIONS WHEN USING POWER TOOLS (AIR OR ELECTRIC) AND HAMMERS

WARNING:

- When working near the Air Bag Diagnosis Sensor Unit or other Air Bag System sensors with the ignition ON or engine running, DO NOT use air or electric power tools or strike near the sensor(s) with a hammer. Heavy vibration could activate the sensor(s) and deploy the air bag(s), possibly causing serious injury.
- When using air or electric power tools or hammers, always switch the ignition OFF, disconnect the battery, and wait at least 3 minutes before performing any service.

Precaution for Procedure without Cowl Top Cover

INFOID:000000004905423

When performing the procedure after removing cowl top cover, cover the lower end of windshield with urethane, etc.

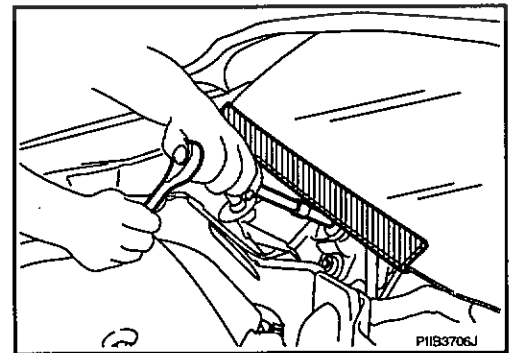

Service Notice or Precautions for Transfer

INFOID:000000004905424

CAUTION:

- After overhaul refill the transfer with new transfer oil.
- Check the oil level or replace the oil only with the vehicle parked on level surface.
- During removal or installation, keep inside of transfer clear of dust or dirt.
- Replace all tires at the same time. Always use tires of the proper size and the same brand and pattern. Fitting improper size and unusual wear tires applies excessive force to vehicle mechanism and can cause longitudinal vibration.
- Disassembly should be done in a clean work area.
- Before proceeding with disassembly, thoroughly clean the transfer. It is important to prevent the internal parts from becoming contaminated by dirt or other foreign matter.

PRECAUTIONS

< PRECAUTION >

[TRANSFER: TY30A]

- Check for the correct installation status prior to removal or disassembly. If matching marks are required, be certain they do not interfere with the function of the parts when applied.
- All parts should be carefully cleaned with a general purpose, non-flammable solvent before inspection or reassembly.
- Check appearance of the disassembled parts for damage, deformation, and unusual wear. Replace them with a new one if necessary.
- Gaskets, seals, O-rings and lock nuts should be replaced any time when the transfer is disassembled.
- In principle, tighten bolts or nuts gradually in several steps working diagonally from inside to outside. If tightening sequence is specified, use it.
- Observe the specified torque when assembling.
- Clean and flush the parts sufficiently and blow-dry them.
- Be careful not to damage sliding surfaces and mating surfaces.
- Use lint-free cloth or towels for wiping parts clean. Common shop rags can leave fibers that could interfere with the operation of the transfer.

دیجیتال خودرو

شرکت دیجیتال خودرو سامانه (مسئولیت محدود)

اولین سامانه دیجیتال تعمیرکاران خودرو در ایران

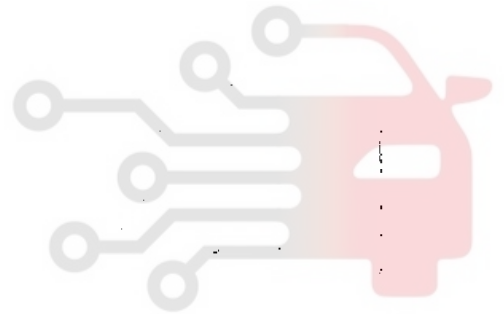

PREPARATION

< PREPARATION >

[TRANSFER: TY30A]

PREPARATION

PREPARATION

M/T

M/T : Special Service Tools

INFOID:0000000004905425

A
B
C

DLN

E
F

G
H

I
J



K
L

M

N

O

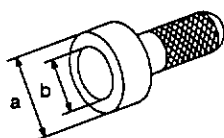
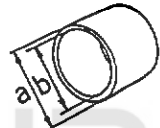
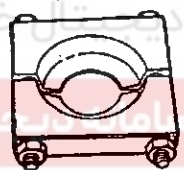

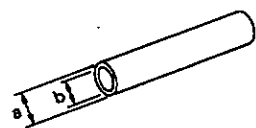
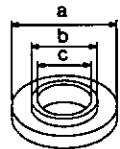
P

Tool number Tool name	Description
ST30720000 Drift a: $\phi 77$ mm (3.03 in) dia. b: $\phi 55.5$ mm (2.185 in) dia.  NT115	<ul style="list-style-type: none"> • Installing adapter case oil seal (inner/outer) • Installing drive pinion oil seal
ST27861000 Drift a: $\phi 62$ mm (2.44 in) dia. b: $\phi 52$ mm (2.05 in) dia.  ZZA1003D	<ul style="list-style-type: none"> • Installing adapter case oil seal (inner/outer) • Installing drive pinion oil seal
ST22730000 Replacer  ZZA0700D	<ul style="list-style-type: none"> • Removing inner race of ring gear shaft bearing (transfer case side) • Removing inner race of drive pinion bearing (front side)
ST33052000 Drift a: $\phi 22$ mm (0.87 in) dia. b: $\phi 28$ mm (1.10 in) dia.  NT116	<ul style="list-style-type: none"> • Removing ring gear • Removing inner race of drive pinion bearing (front side)
ST01530000 Drift a: $\phi 48$ mm (1.89 in) dia. b: $\phi 41$ mm (1.61 in) dia.  ZZA0534D	Installing ring gear
ST35272000 Drift a: $\phi 72$ mm (2.83 in) dia. b: $\phi 40$ mm (1.57 in) dia. c: $\phi 35.5$ mm (1.398 in) dia.  NT107	<ul style="list-style-type: none"> • Installing ring gear • Installing outer race of drive pinion bearing (front side)

PREPARATION

< PREPARATION >

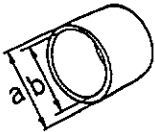
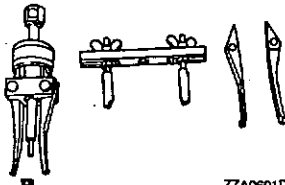
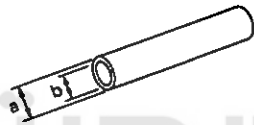
[TRANSFER: TY30A]

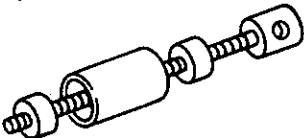
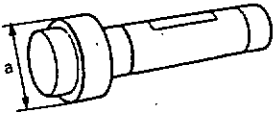
Tool number Tool name	Description
KV10111400 Drift a: $\phi 25$ mm (0.98 in) dia. b: $\phi 20.8$ mm (0.819 in) dia. <div style="text-align: center;">  <p>ZZA1003D</p> </div>	Installing inner race of ring gear shaft bearing (transfer case side)
KV381054S0 Puller <div style="text-align: center;">  <p>ZZA0601D</p> </div>	Removing drive pinion oil seal
ST23860000 Drift a: $\phi 38$ mm (1.50 in) dia. b: $\phi 33$ mm (1.30 in) dia. <div style="text-align: center;">  <p>ZZA0534D</p> </div>	Installing inner race of drive pinion bearing (front side)
ST3127S000 Preload gauge <div style="text-align: center;">  <p>ZZA0503D</p> </div>	Measuring preload torque
ST38280000 Bushing remover <div style="text-align: center;">  <p>NT685</p> </div>	Installing outer race of drive pinion bearing (front side)
ST33230000 Drift a: $\phi 51$ mm (2.01 in) dia. <div style="text-align: center;">  <p>ZZA0938D</p> </div>	Installing outer race of drive pinion bearing (rear side)

PREPARATION

< PREPARATION >

[TRANSFER: TY30A]

M/T : Commercial Service Tools

INFOID:000000004905426

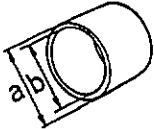
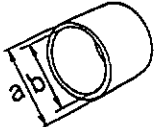
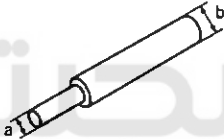
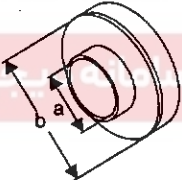
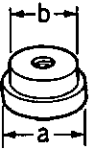
Tool name	Description
Drift a: $\phi 63$ mm (2.48 in) dia. b: $\phi 58$ mm (2.28 in) dia.  ZZA1003D	Installing adapter case oil seal (inner)
Drift a: $\phi 90$ mm (3.54 in) dia. b: $\phi 88$ mm (3.46 in) dia.  ZZA1003D	Installing adapter case oil seal (outer)
Drift a: $\phi 12$ mm (0.47 in) dia. b: $\phi 18$ mm (0.71 in) dia.  ZZA1178D	Removing inner race of ring gear shaft bearing (transfer case side)
Drift a: $\phi 49$ mm (1.93 in) dia. b: $\phi 67$ mm (2.64 in) dia.  NT660	Removing inner race of ring gear shaft bearing (adapter case side)
Drift a: $\phi 80$ mm (3.15 in) dia. b: $\phi 50$ mm (1.97 in) dia.  ZZA1000D	Installing outer race of ring gear shaft bearing (adapter case side)

A
B
C
DLN
E
F
G
H
I
J
K
L
M
N
O
P

PREPARATION

< PREPARATION >

[TRANSFER: TY30A]

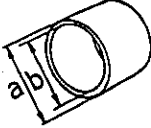
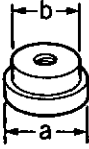
Tool name	Description
Drift a: $\phi 57$ mm (2.24 in) dia. b: $\phi 47$ mm (1.85 in) dia.  ZZA1003D	Installing inner race of ring gear shaft bearing (adapter case side)
Drift a: $\phi 61$ mm (2.40 in) dia. b: $\phi 48$ mm (1.89 in) dia.  ZZA1000D	Installing outer race of drive pinion bearing (front side)

CVT

CVT : Special Service Tools

INFOID:0000000004905427

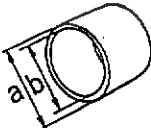
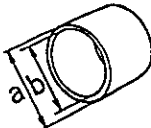
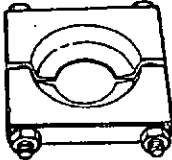
Tool number Tool name	Description
ST30720000 Drift a: $\phi 77$ mm (3.03 in) dia. b: $\phi 55.5$ mm (2.185 in) dia.  NT115	<ul style="list-style-type: none"> Installing adapter case oil seal Installing drive pinion oil seal
ST27861000 Drift a: $\phi 62$ mm (2.44 in) dia. b: $\phi 52$ mm (2.05 in) dia.  ZZA1003D	<ul style="list-style-type: none"> Installing adapter case oil seal Installing drive pinion oil seal
KV40104830 Drift a: $\phi 70$ mm (2.76 in) dia. b: $\phi 63.5$ mm (2.500 in) dia.  ZZA1003D	Installing adapter case oil seal
ST22730000 Replacer  ZZA0700D	<ul style="list-style-type: none"> Removing inner race of ring gear shaft bearing (transfer case side) Removing inner race of drive pinion bearing (front side)

PREPARATION

< PREPARATION >

[TRANSFER: TY30A]

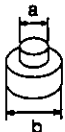
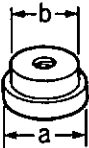
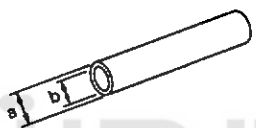
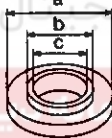
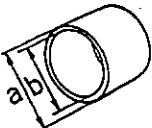
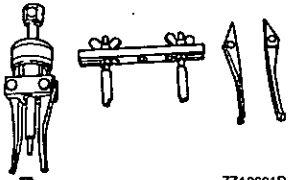
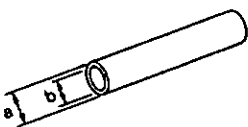
Tool number Tool name	Description	A
ST33052000 Drift a: $\phi 22$ mm (0.87 in) dia. b: $\phi 28$ mm (1.10 in) dia.	 NT116 <ul style="list-style-type: none"> • Removing ring gear • Removing inner race of drive pinion bearing (front side) 	B C
ST30621000 Drift a: $\phi 72$ mm (2.83 in) dia. b: $\phi 48$ mm (1.89 in) dia.	 ZZA1000D <ul style="list-style-type: none"> • Installing outer race of ring gear shaft bearing (adapter case side) • Installing outer race of drive pinion bearing (front side) 	DLN E
ST01530000 Drift a: $\phi 48$ mm (1.89 in) dia. b: $\phi 41$ mm (1.61 in) dia.	 ZZA0534D <p>Installing ring gear</p>	F G
ST35272000 Drift a: $\phi 72$ mm (2.83 in) dia. b: $\phi 40$ mm (1.57 in) dia. c: $\phi 35.5$ mm (1.398 in) dia.	 NT107 <ul style="list-style-type: none"> • Installing ring gear • Installing outer race of drive pinion bearing (front side) 	H I J
KV10111400 Drift a: $\phi 25$ mm (0.98 in) dia. b: $\phi 20.8$ mm (0.819 in) dia.	 ZZA1003D <p>Installing inner race of ring gear shaft bearing (transfer case side)</p>	K L M
KV381054S0 Puller	 ZZA0601D <p>Removing drive pinion oil seal</p>	N O
ST23860000 Drift a: $\phi 38$ mm (1.50 in) dia. b: $\phi 33$ mm (1.30 in) dia.	 ZZA0534D <p>Installing inner race of drive pinion bearing (front side)</p>	P

PREPARATION

< PREPARATION >

[TRANSFER: TY30A]

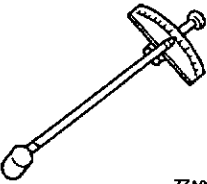
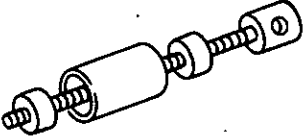
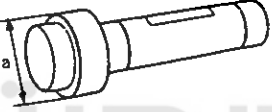
Tool number Tool name	Description
ST3127S000 Preload gauge  ZZA0603D	Measuring preload torque
ST38280000 Bushing remover  NT685	Installing outer race of drive pinion bearing (front side)
ST33230000 Drift a: $\phi 51$ mm (2.01 in) dia.  ZZA0938D	Installing outer race of drive pinion bearing (rear side)

CVT : Commercial Service Tools

INFOID:000000004905428

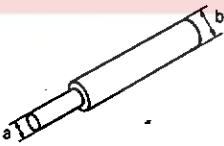
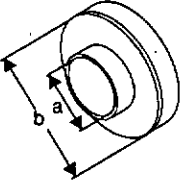
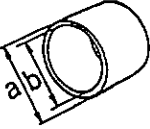
Tool name	Description
Drift a: $\phi 12$ mm (0.47 in) dia. b: $\phi 18$ mm (0.71 in) dia.  ZZA1178D	Removing inner race of ring gear shaft bearing (transfer case side)
Drift a: $\phi 49$ mm (1.93 in) dia. b: $\phi 67$ mm (2.64 in) dia.  NT660	Removing inner race of ring gear shaft bearing (adapter case side)
Drift a: $\phi 57$ mm (2.24 in) dia. b: $\phi 47$ mm (1.85 in) dia.  ZZA1003D	Installing inner race of ring gear shaft bearing (adapter case side)

ON-VEHICLE MAINTENANCE

TRANSFER OIL

Inspection

INFOID:000000004905429

OIL LEAKAGE

Check transfer surrounding area (oil seal, drain plug, filler plug, and transfer case, etc.) for oil leakage.

OIL LEVEL

1. Remove filler plug (1) and gasket. Then check that oil is filled up (A) from mounting hole for the filler plug.
2. Before installing filler plug, set a new gasket. Install filler plug on transfer and tighten to the specified torque. Refer to DLN-56, "M/T : Exploded View" (M/T), DLN-59, "CVT : Exploded View" (CVT).

CAUTION:

Never reuse gaskets.

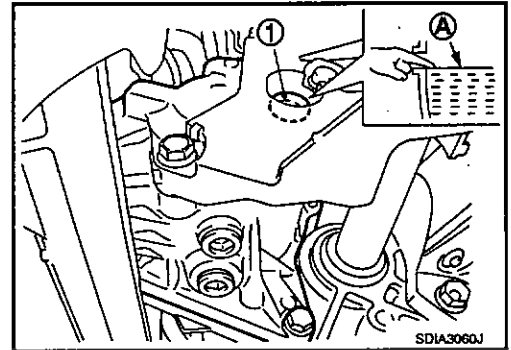

SDIA3060J

Draining

INFOID:000000004905430

1. Run the vehicle to warm up the transfer unit sufficiently.
2. Stop the engine and remove drain plug (1) and gaskets to drain the transfer oil.

CAUTION:

Never remove tooth contact test hole plug (2).

3. Before installing drain plug, set a new gasket. Install drain plug on transfer and tighten to the specified torque. Refer to DLN-56, "M/T : Exploded View" (M/T), DLN-59, "CVT : Exploded View" (CVT).

CAUTION:

Never reuse gaskets.

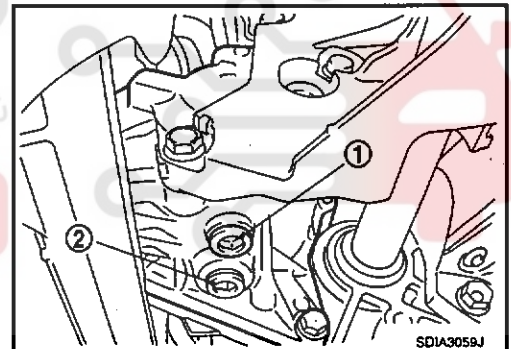

SDIA3059J

Refilling

INFOID:000000004905431

1. Remove filler plug (1) and gasket. Then fill oil up to mounting hole (A) for the filler plug.

Oil grade and viscosity : Refer to MA-13, "Fluids and Lubricants".

Oil capacity : Refer to DLN-102, "General Specifications".

CAUTION:

Carefully fill the oil. (Fill up for approximately 3 minutes.)

2. Leave the vehicle for 3 minutes. Then check oil level again.
3. Before installing filler plug, set a new gasket. Install filler plug on transfer and tighten to the specified torque. Refer to DLN-56, "M/T : Exploded View" (M/T), DLN-59, "CVT : Exploded View" (CVT).

CAUTION:

Never reuse gasket.

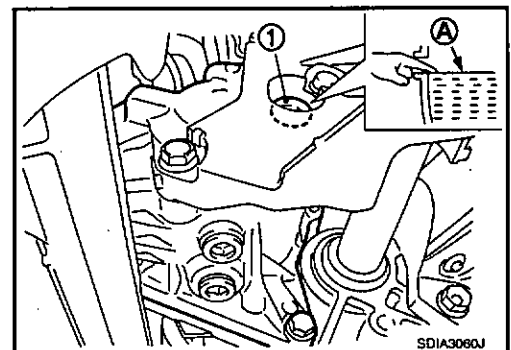

SDIA3060J

< ON-VEHICLE REPAIR >

[TRANSFER: TY30A]

ON-VEHICLE REPAIR

4WD CONTROL UNIT

LHD

LHD : Exploded View

INFOID:000000004905432

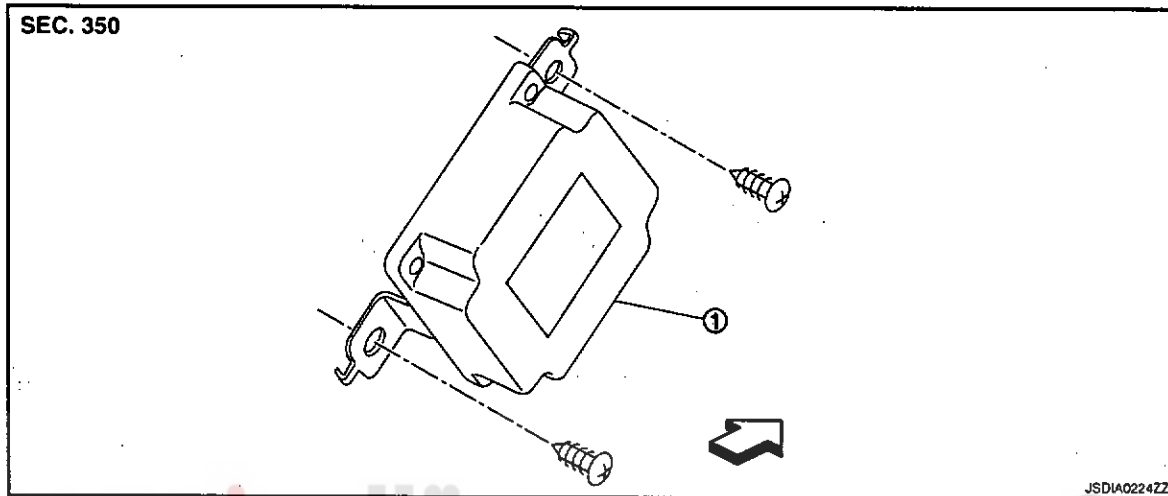

1. 4WD control unit

←: Vehicle front

LHD : Removal and Installation

INFOID:000000004905433

REMOVAL

1. Remove the glove box cover assembly. Refer to IP-11, "Exploded View".
2. Disconnect 4WD control unit harness connector.
3. Remove 4WD control unit (1) mounting screws.
4. Remove 4WD control unit.

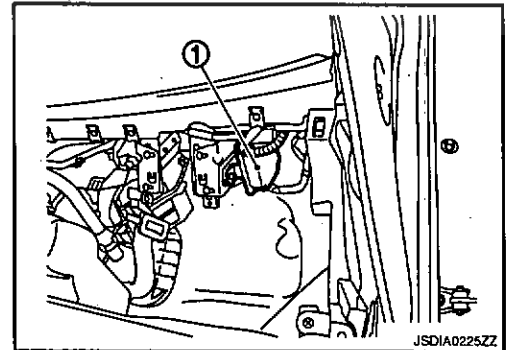

INSTALLATION

Install in the reverse order of removal.

RHD

4WD CONTROL UNIT

< ON-VEHICLE REPAIR >

[TRANSFER: TY30A]

RHD : Exploded View

INFOID:000000004905434

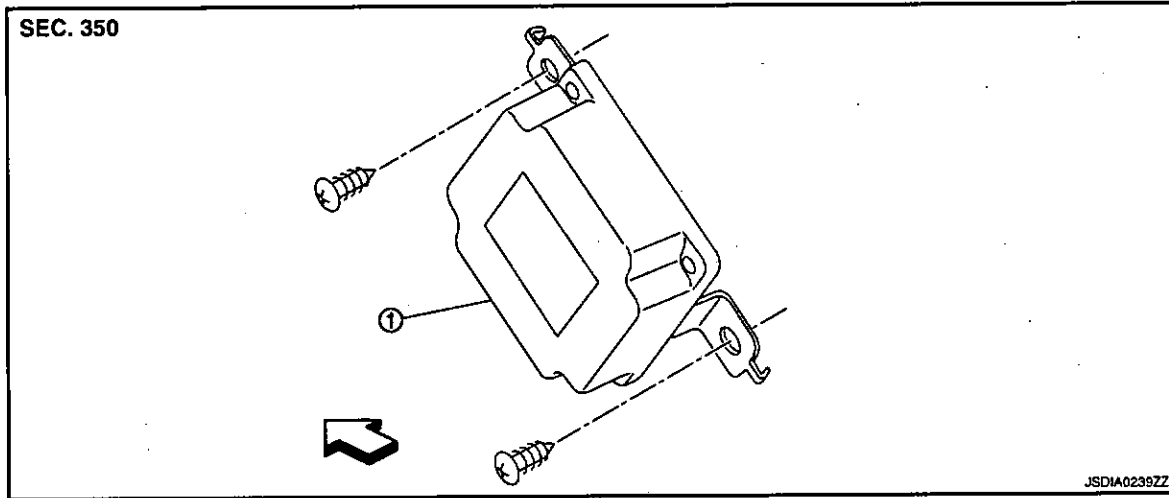

- 1. 4WD control unit

↔: Vehicle front

RHD : Removal and Installation

INFOID:000000004905435

REMOVAL

1. Remove the glove box cover assembly. Refer to IP-11, "Exploded View".
2. Disconnect 4WD control unit harness connector.
3. Remove 4WD control unit (1) mounting screws.
4. Remove 4WD control unit.

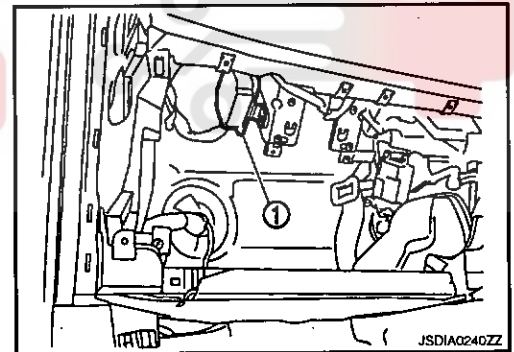

INSTALLATION

Install in the reverse order of removal.

A
B
C
DLN
E
F
G
H
I
J
K
L
M
N
O
P

TRANSFER ASSEMBLY

< REMOVAL AND INSTALLATION >

[TRANSFER: TY30A]

REMOVAL AND INSTALLATION

TRANSFER ASSEMBLY

MR20DE (M/T)

MR20DE (M/T) : Exploded View

INFOID:000000004905436

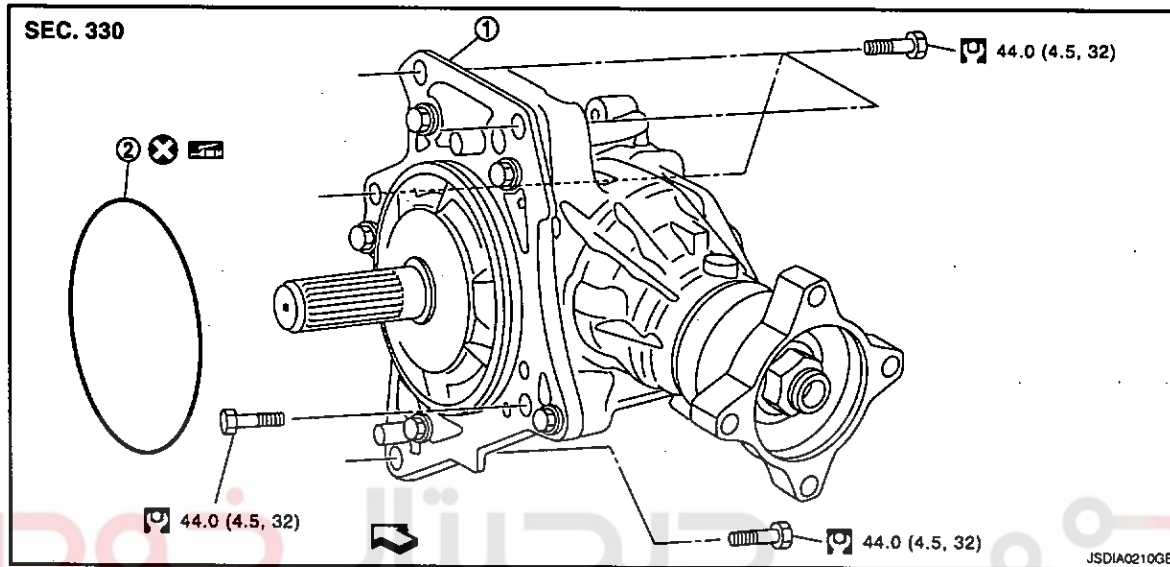

- 1. Transfer assembly
- 2. O-ring (outer)

← Vehicle front

Apply multi-purpose grease.

Refer to GI-3, "Components" for symbols not described on the above.

MR20DE (M/T) : Removal and Installation

INFOID:000000004905437

REMOVAL

1. Remove the exhaust front tube. Refer to EX-10, "Exploded View".
2. Remove the exhaust manifold. Refer to EM-151, "Exploded View".
3. Separate the rear propeller shaft. Refer to DLN-105, "Exploded View".
4. Remove right side drive shaft and support bearing bracket. Refer to FAX-60, "MR20DE MODELS : Exploded View".
5. Remove the mounting bolts (↔) of transaxle assembly and transfer assembly.
CAUTION:
Never remove the mounting bolts (↔) of adapter case.
6. Remove transfer assembly from the vehicle.
CAUTION:
 - Never damage ring gear shaft.
 - Never damage air breather hose.
7. Remove O-ring (outer) from the transfer assembly.

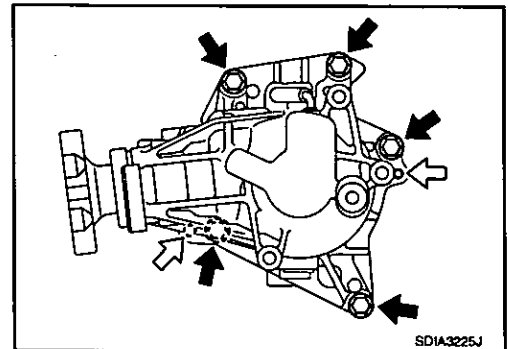

SDIA3225J

INSTALLATION

Note the following, and install in the reverse order of removal.

- Apply multi-purpose grease lightly and evenly onto an O-ring (outer), and install it to the transfer assembly.

CAUTION:

Never reuse O-ring (outer).

TRANSFER ASSEMBLY

[TRANSFER: TY30A]

< REMOVAL AND INSTALLATION >

- Install mounting bolts according to the standard below when installing transfer assembly to the transaxle assembly.

Bolt symbol	A	B
Installation direction	Transfer ⇒ Transaxle	Transaxle ⇒ Transfer

- Check oil level and check for oil leakage after installation. Refer to DLN-49, "Inspection".

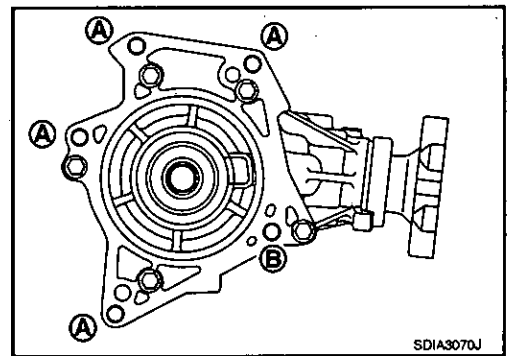

A
B
C

DLN

MR20DE (CVT)

MR20DE (CVT) : Exploded View

INFOID:000000004905438

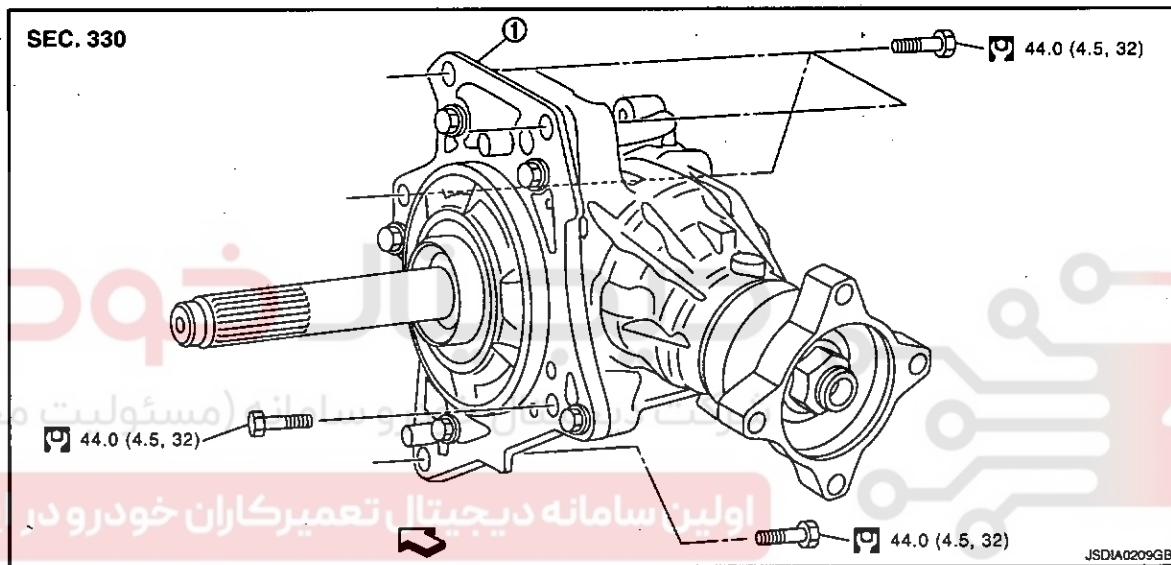

E
F
G
H
I
J

K

L

M

N

O

P

1. Transfer assembly

↔: Vehicle front

Refer to GI-3, "Components" for symbols in the figure.

MR20DE (CVT) : Removal and Installation

INFOID:000000004905439

REMOVAL

1. Remove the exhaust front tube. Refer to EX-10, "Exploded View".
2. Remove the exhaust manifold. Refer to EM-151, "Exploded View".
3. Separate the rear propeller shaft. Refer to DLN-105, "Exploded View".
4. Remove right side drive shaft and support bearing bracket. Refer to FAX-60, "MR20DE MODELS : Exploded View".

TRANSFER ASSEMBLY

< REMOVAL AND INSTALLATION >

[TRANSFER: TY30A]

5. Remove the mounting bolts (↔) of transaxle assembly and transfer assembly.
CAUTION:
Never remove the mounting bolts (↔) of adapter case.
6. Remove transfer assembly from the vehicle.
CAUTION:
 - Never damage ring gear shaft.
 - Never damage air breather hose.

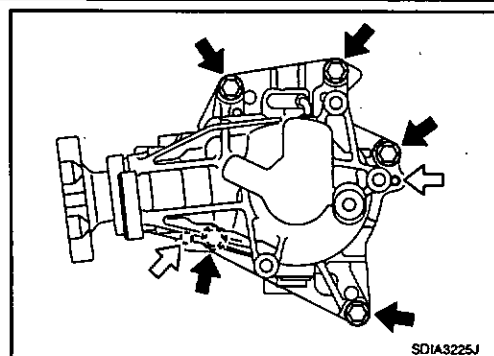

INSTALLATION

Note the following, and install in the reverse order of removal.

- Install mounting bolts according to the standard below when installing transfer assembly to the transaxle assembly.

Bolt symbol	A	B
Installation direction	Transfer ⇒ Transaxle	Transaxle ⇒ Transfer

CAUTION:

- When installing transfer assembly to transaxle assembly, replace the side oil seal (transfer joint). Refer to TM-92, "4WD : Exploded View".
- Never damage side seal (the joint part of transfer) and dust cover of transaxle assembly.
- Check oil level and check for oil leakage after installation. Refer to DLN-49, "Inspection".

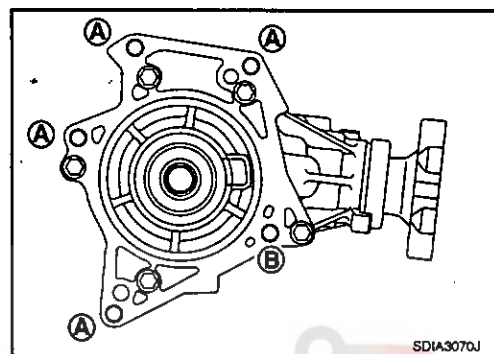

M9R

M9R : Exploded View

INFOID:000000004905440

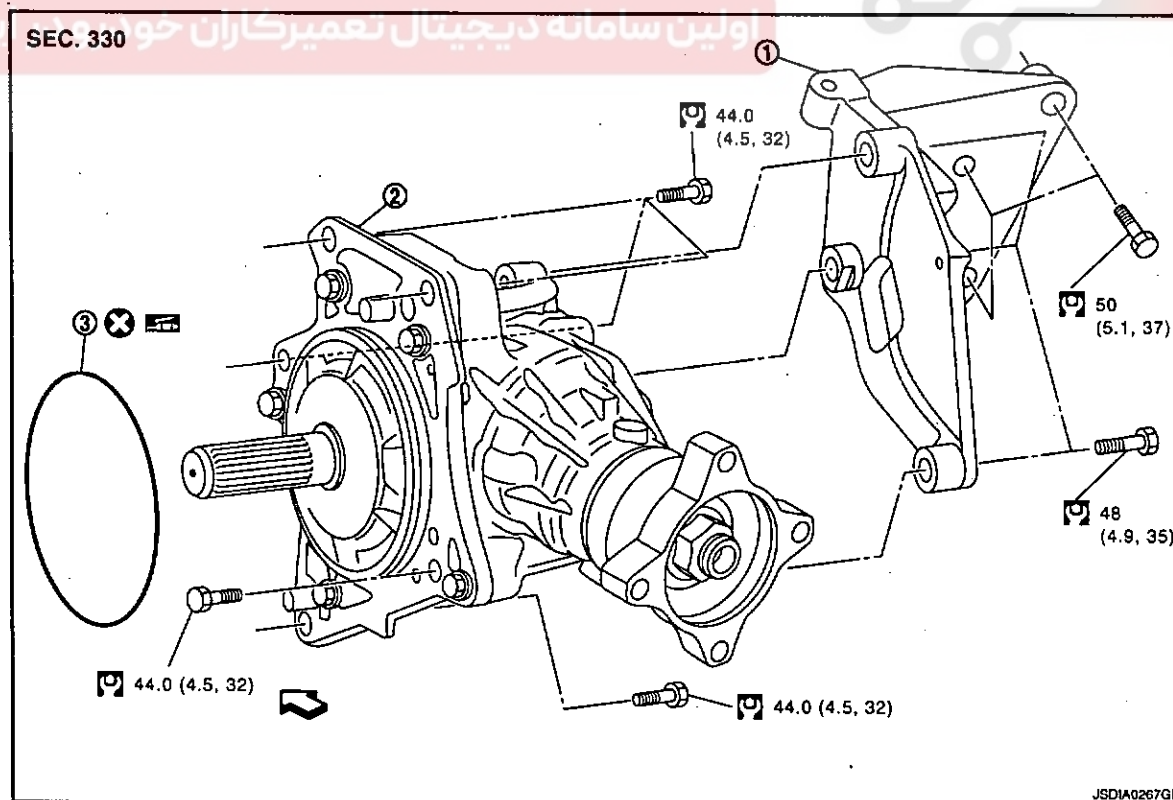

1. Gusset

2. Transfer assembly

3. O-ring (outer)

TRANSFER ASSEMBLY

< REMOVAL AND INSTALLATION >

[TRANSFER: TY30A]

↔: Vehicle front

: Apply multi-purpose grease.

Refer to GI-3. "Components" for symbols not described on the above.

M9R : Removal and Installation

INFOID:000000004905441

REMOVAL

1. Remove the exhaust front tube. Refer to EX-15. "Removal and Installation".
2. Separate the rear propeller shaft. Refer to DLN-105. "Exploded View".
3. Remove right side drive shaft and support bearing bracket. Refer to FAX-68. "M9R MODELS : Exploded View".
4. Remove bracket, turbocharger cooling pump and water hose. Refer to EM-277. "Exploded View".
5. Remove the mounting bolts of catalyst cover. Refer to EM-275. "Exploded View".
6. Remove the mounting bolts of water pipe. Refer to EM-277. "Exploded View".
7. Remove the gusset.
8. Separate the rear torque rod. Refer to EM-315. "Exploded View".
9. Remove the mounting bolts (↔) of transaxle assembly and transfer assembly.

CAUTION:

Never remove the mounting bolts (↔) of adapter case.

10. Remove transfer assembly from the vehicle.

CAUTION:

- Never damage ring gear shaft.
- Never damage air breather hose.

11. Remove O-ring (outer) from the transfer assembly.

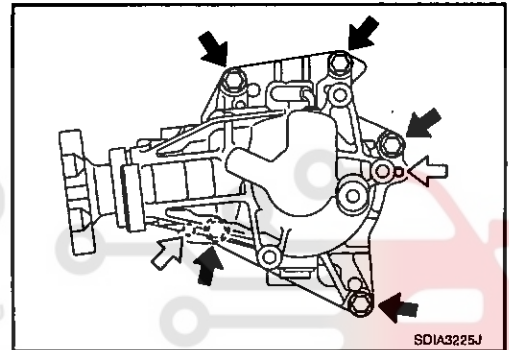

INSTALLATION

Note the following, and install in the reverse order of removal.

- Apply multi-purpose grease lightly and evenly onto an O-ring (outer), and install it to the transfer assembly.

CAUTION:

Never reuse O-ring (outer).

- Install mounting bolts according to the standard below when installing transfer assembly to the transaxle assembly.

Bolt symbol	A	B
Installation direction	Transfer ⇒ Transaxle	Transaxle ⇒ Transfer

- Check oil level and check for oil leakage after installation. Refer to DLN-49. "Inspection".

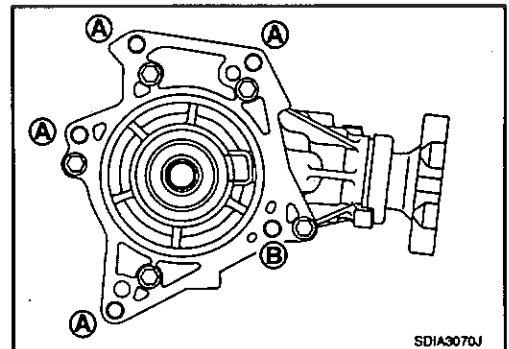

ADAPTER CASE

< DISASSEMBLY AND ASSEMBLY >

[TRANSFER: TY30A]

DISASSEMBLY AND ASSEMBLY

ADAPTER CASE

M/T

M/T : Exploded View

INFOID.000000004905442

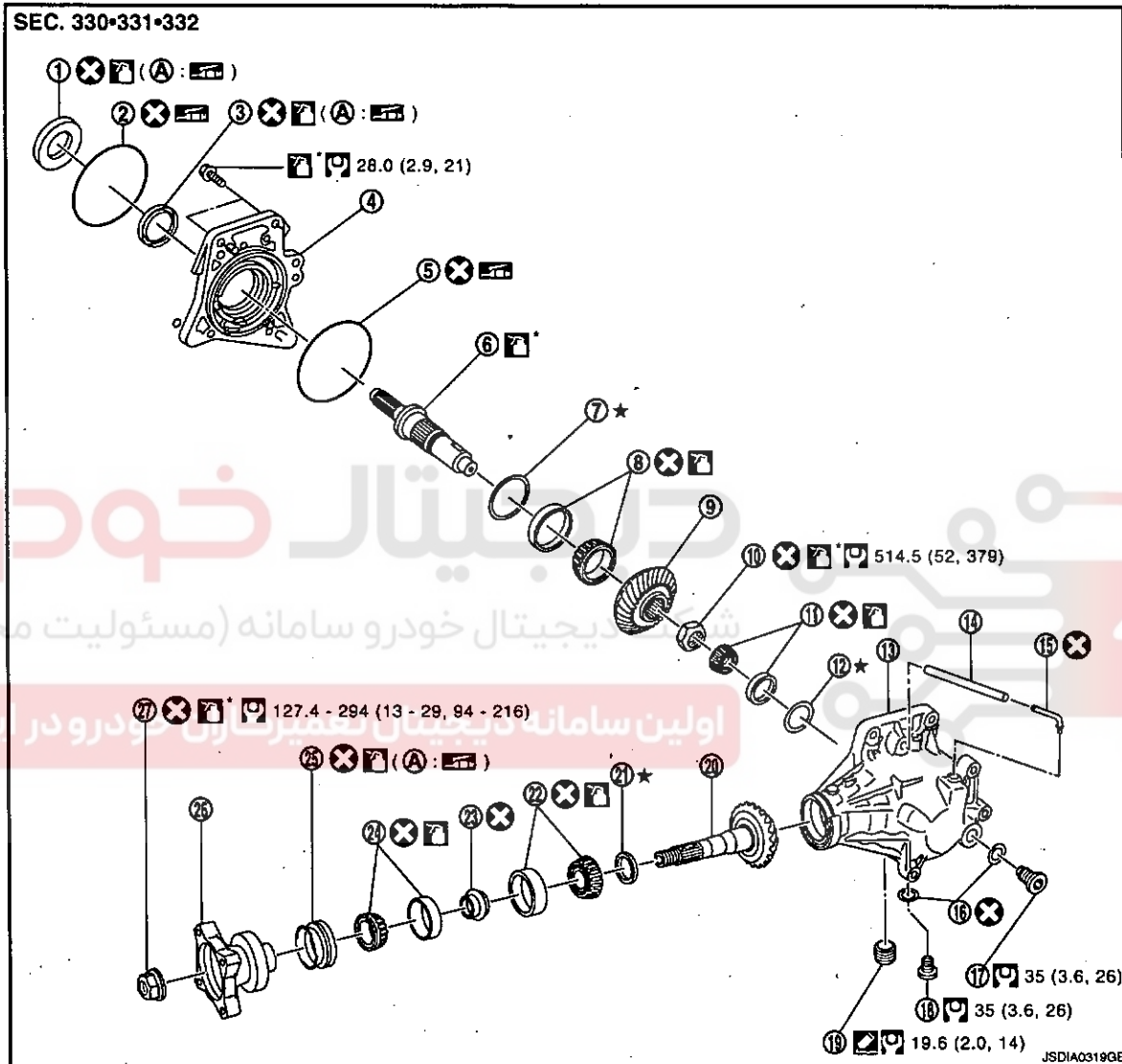

- | | | |
|---|--|---|
| 1. Adapter case oil seal (outer) | 2. O-ring (outer) | 3. Adapter case oil seal (inner) |
| 4. Adapter case | 5. O-ring (inner) | 6. Ring gear shaft |
| 7. Ring gear adjusting shim (adapter case side) | 8. Ring gear shaft bearing (adapter case side) | 9. Ring gear |
| 10. Ring gear nut | 11. Ring gear shaft bearing (transfer case side) | 12. Ring gear adjusting shim (transfer case side) |
| 13. Transfer case | 14. Air breather hose | 15. Air breather tube |
| 16. Gasket | 17. Filler plug | 18. Drain plug |
| 19. Plug | 20. Drive pinion | 21. Drive pinion adjusting shim |
| 22. Drive pinion bearing (front side) | 23. Collapsible spacer | 24. Drive pinion bearing (rear side) |
| 25. Drive pinion oil seal | 26. Companion flange | 27. Lock nut |

A: Oil seal lip

ADAPTER CASE

< DISASSEMBLY AND ASSEMBLY >

[TRANSFER: TY30A]

: Apply gear oil.

: Apply multi-purpose grease.

*: Apply anti-corrosive oil.

: Apply Genuine Liquid Gasket, Three Bond 1215 or an equivalent.

Refer to Gl-3. "Components" for symbols not described on the above.

M/T : Disassembly

INFOID:000000004905443

1. Remove O-ring (outer) from adapter case.
2. Remove adapter case mounting bolts (←).

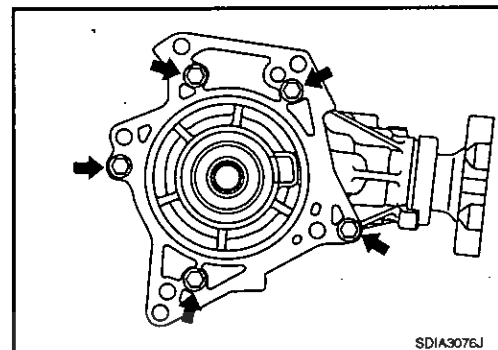

3. Lightly tap adapter case with a plastic hammer to remove adapter case.
4. Remove O-ring (inner) from adapter case.

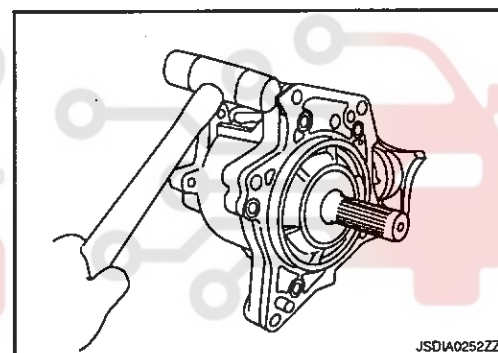

شرکت دیجیتال خودرو سامانه (مسئولیت محدود)

اولین سامانه دیجیتال تعمیرکاران خودرو در ایران

5. Remove adapter case oil seal (outer/inner) with a screwdriver.
CAUTION:
Be careful not to damage adapter case.

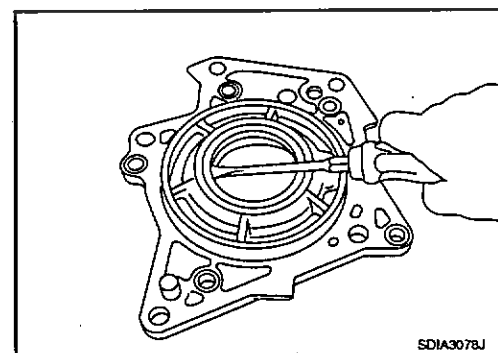

M/T : Assembly

INFOID:000000004905444

1. Install O-ring (inner) to adapter case.
CAUTION:
 - Never reuse O-ring (inner).
 - Apply multi-purpose grease to O-ring (inner).
2. Install adapter case to the transfer case.

ADAPTER CASE

< DISASSEMBLY AND ASSEMBLY >

[TRANSFER: TY30A]

3. Apply anti-corrosive oil onto threads and seats of bolts (←), and tighten with the specified torque.
4. Check backlash, tooth contact, total preload and companion flange runout. Refer to DLN-73, "M/T : Adjustment".

CAUTION:

Measure the total preload without the adapter case oil seal (outer/inner).

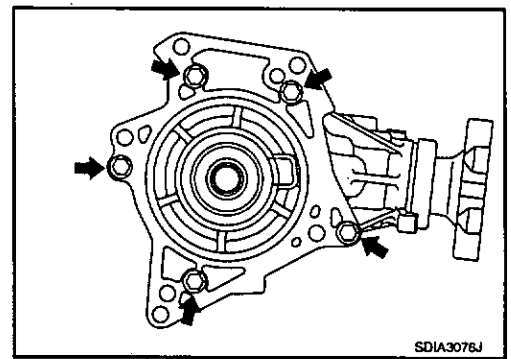

5. Install adapter case oil seal (inner) (1) to the adapter case with drifts.

- A : Drift (SST: ST30720000)
- B : Drift (SST: ST27861000)
- C : Drift (commercial service tool)

Dimension "D" : 0 – 1.0 mm

CAUTION:

- Never reuse oil seal.
- Apply multi-purpose grease onto oil seal lips, and gear oil onto the circumference.
- Install adapter case oil seal (inner) in the direction shown in the figure.

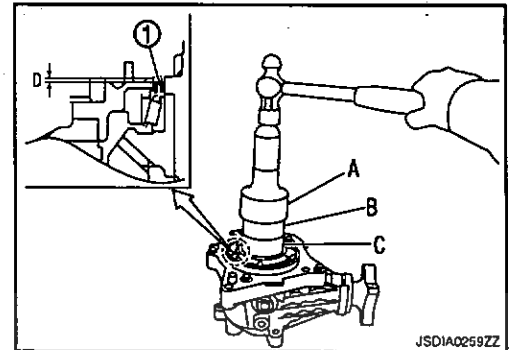

6. Install adapter case oil seal (outer) (1) to the adapter case with drifts so that it becomes flush with adapter case end surface.

- A : Drift (SST: ST30720000)
- B : Drift (SST: ST27861000)
- C : Drift (commercial service tool)

CAUTION:

- Never reuse oil seal.
- Apply multi-purpose grease onto oil seal lips, and gear oil onto the circumference.
- Install adapter case oil seal (outer) in the direction shown in the figure.

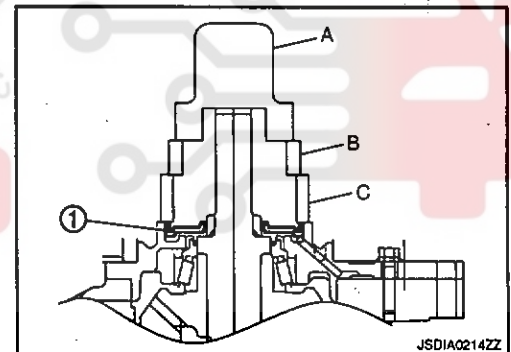

7. Install O-ring (outer) to the adapter case.

M/T : Inspection After Disassembly

Check items below. If necessary, replace them with new ones.

CASE

Check the bearing mounting surface for wear, cracks and damages.

CVT

INFOID:000000004905445

ADAPTER CASE

< DISASSEMBLY AND ASSEMBLY >

[TRANSFER: TY30A]

CVT : Exploded View

INFOID:0000000004905446

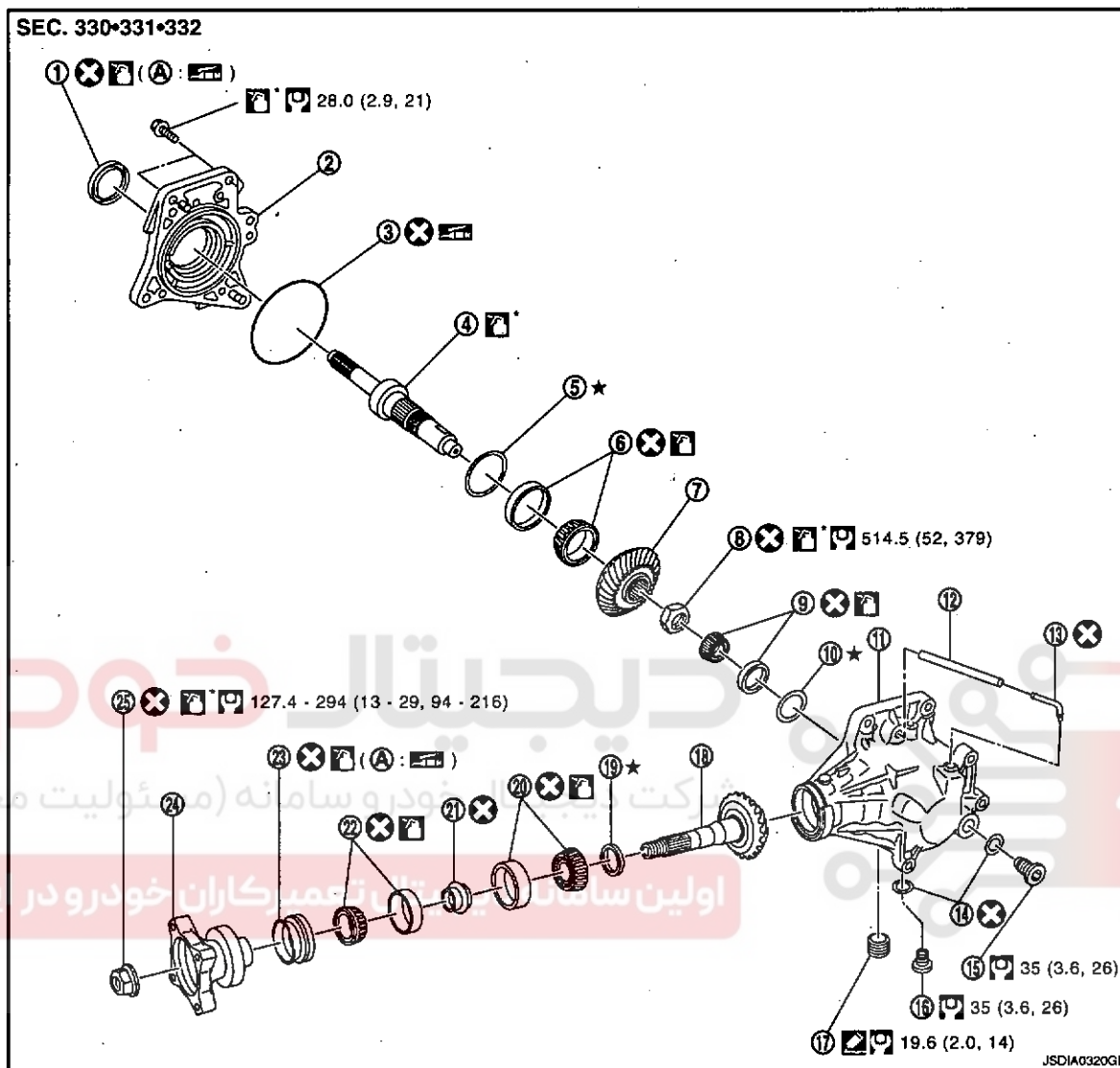

- | | | |
|---|---|---|
| 1. Adapter case oil seal | 2. Adapter case | 3. O-ring |
| 4. Ring gear shaft | 5. Ring gear adjusting shim (adapter case side) | 6. Ring gear shaft bearing (adapter case side) |
| 7. Ring gear | 8. Ring gear nut | 9. Ring gear shaft bearing (transfer case side) |
| 10. Ring gear adjusting shim (transfer case side) | 11. Transfer case | 12. Air breather hose |
| 13. Air breather tube | 14. Gasket | 15. Filler plug |
| 16. Drain plug | 17. Plug | 18. Drive pinion |
| 19. Drive pinion adjusting shim | 20. Drive pinion bearing (front side) | 21. Collapsible spacer |
| 22. Drive pinion bearing (rear side) | 23. Drive pinion oil seal | 24. Companion flange |
| 25. Lock nut | | |
- A: Oil seal lip



Apply gear oil.



Apply multi-purpose grease.



Apply anti-corrosive oil.

A
B
C
DLN
E
F
G
H
I
J
K
L
M
N
O
P

ADAPTER CASE

< DISASSEMBLY AND ASSEMBLY >

[TRANSFER: TY30A]

-  Apply Genuine Liquid Gasket, Three Bond 1215 or an equivalent.
Refer to GI-3, "Components" for symbols not described on the above.

CVT : Disassembly

INFOID:000000004905447

1. Remove adapter case mounting bolts (←).

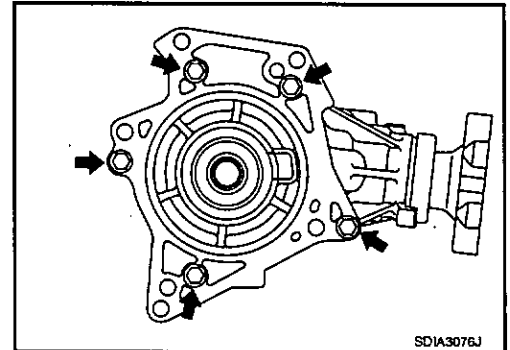

2. Lightly tap adapter case with a plastic hammer to remove adapter case.
3. Remove O-ring from adapter case.

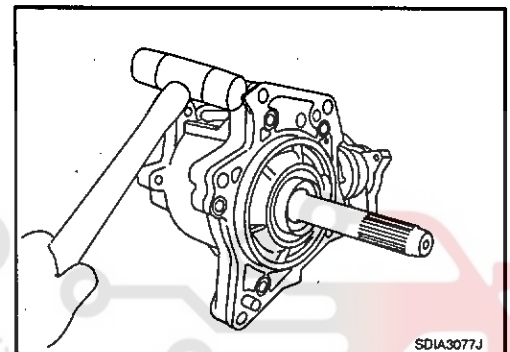

4. Remove adapter case oil seal with a screwdriver.

CAUTION:

Be careful not to damage adapter case.

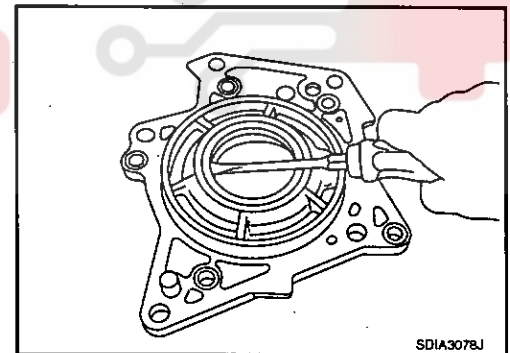

CVT : Assembly

INFOID:000000004905448

1. Install O-ring to adapter case.
CAUTION:
 - Never reuse O-ring.
 - Apply multi-purpose grease to O-ring.
2. Install adapter case to the transfer case.

ADAPTER CASE

[TRANSFER: TY30A]

< DISASSEMBLY AND ASSEMBLY >

3. Apply anti-corrosive oil onto threads and seats of bolts (←), and tighten with the specified torque.
4. Check backlash, tooth contact, total preload and companion flange runout. Refer to DLN-86, "CVT : Adjustment".

CAUTION:

Measure the total preload without the adapter case oil seal.

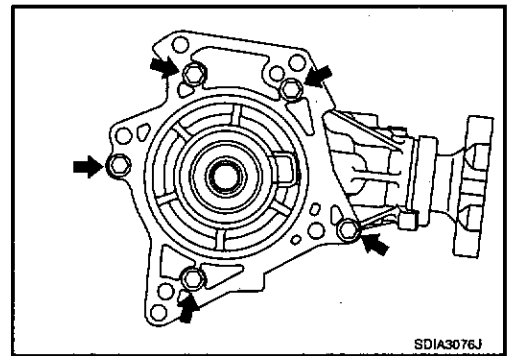

5. Install adapter case oil seal (1) to the adapter case with drifts.

- A : Drift (SST: ST30720000)
- B : Drift (SST: ST27861000)
- C : Drift (SST: KV40104830)

Dimension "D" : 0.5 – 1.5 mm

CAUTION:

- Never reuse adapter case oil seal.
- Apply multi-purpose grease onto oil seal lips, and gear oil onto the circumference.

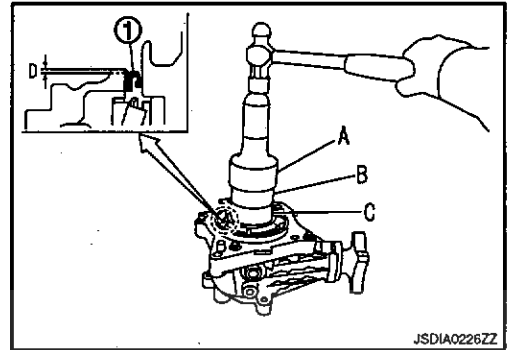

CVT : Inspection After Disassembly

Check items below. If necessary, replace them with new ones.

CASE

Check the bearing mounting surface for wear, cracks and damages.

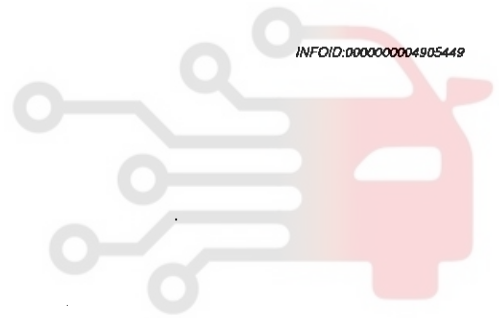

اولین سامانه دیجیتال تعمیرکاران خودرو در ایران

A
B
C
DLN
E
F
G
H
I
J
K
L
M
N
O
P

RING GEAR SHAFT

< DISASSEMBLY AND ASSEMBLY >

[TRANSFER: TY30A]

RING GEAR SHAFT

M/T

M/T : Exploded View

INFOID:000000004905450

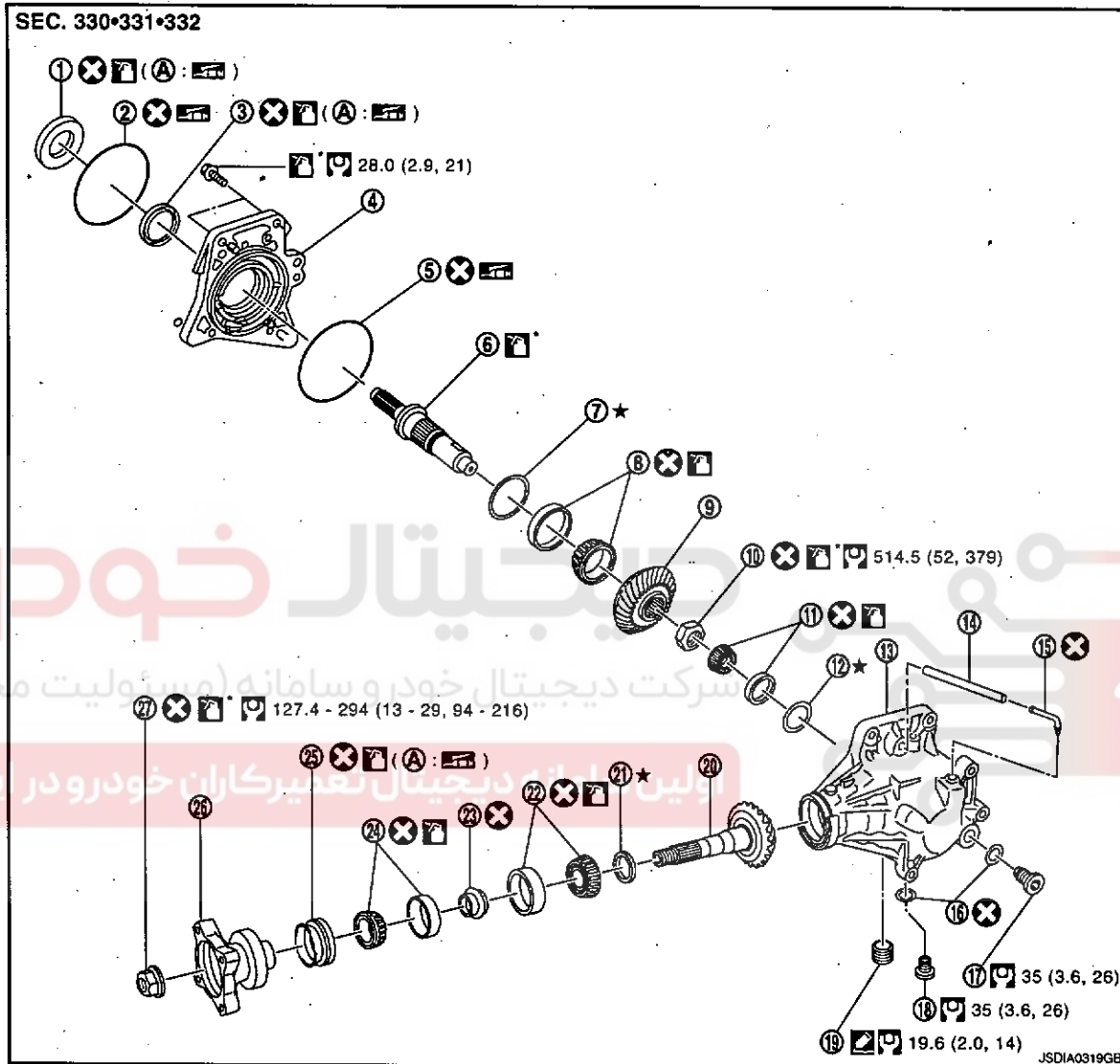

- | | | |
|---|--|---|
| 1. Adapter case oil seal (outer) | 2. O-ring (outer) | 3. Adapter case oil seal (inner) |
| 4. Adapter case | 5. O-ring (inner) | 6. Ring gear shaft |
| 7. Ring gear adjusting shim (adapter case side) | 8. Ring gear shaft bearing (adapter case side) | 9. Ring gear |
| 10. Ring gear nut | 11. Ring gear shaft bearing (transfer case side) | 12. Ring gear adjusting shim (transfer case side) |
| 13. Transfer case | 14. Air breather hose | 15. Air breather tube |
| 16. Gasket | 17. Filler plug | 18. Drain plug |
| 19. Plug | 20. Drive pinion | 21. Drive pinion adjusting shim |
| 22. Drive pinion bearing (front side) | 23. Collapsible spacer | 24. Drive pinion bearing (rear side) |
| 25. Drive pinion oil seal | 26. Companion flange | 27. Lock nut |

A: Oil seal lip

: Apply gear oil.

: Apply multi-purpose grease.

RING GEAR SHAFT

< DISASSEMBLY AND ASSEMBLY >

[TRANSFER: TY30A]

: Apply anti-corrosive oil.

: Apply Genuine Liquid Gasket, Three Bond 1215 or an equivalent.
Refer to GI-3, "Components" for symbols not described on the above.

M/T : Disassembly

INFOID:000000004905451

1. Remove adapter case. Refer to DLN-57, "M/T : Disassembly".
2. Remove adapter case oil seal (outer/inner) from the adapter case. Refer to DLN-57, "M/T : Disassembly".

3. Tap the ring gear adjusting shim from the cutout on the adapter case with a brass rod to remove ring gear shaft bearing outer race (adapter case side) and ring gear adjusting shim (adapter case side).

CAUTION:
Be careful not to damage adapter case.

4. Remove ring gear shaft assembly from the transfer case.
5. Remove outer race of ring gear shaft bearing (transfer case side) and ring gear adjusting shim (transfer case side) from the transfer case.

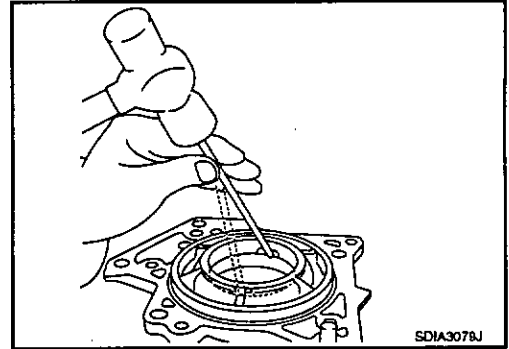

6. Remove inner race of ring gear shaft bearing (transfer case side) from ring gear shaft with drift (A) (commercial service tool) and replacer (B) (SST: ST22730000).

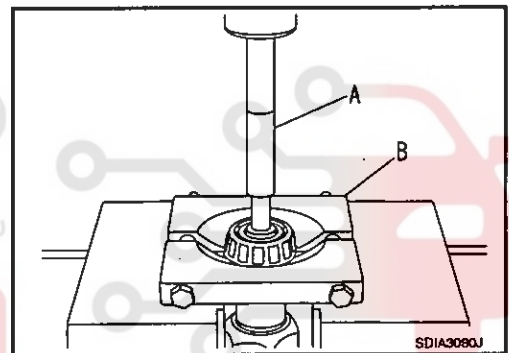

7. Remove ring gear nut (1).
CAUTION:
Never damage ring gear shaft.

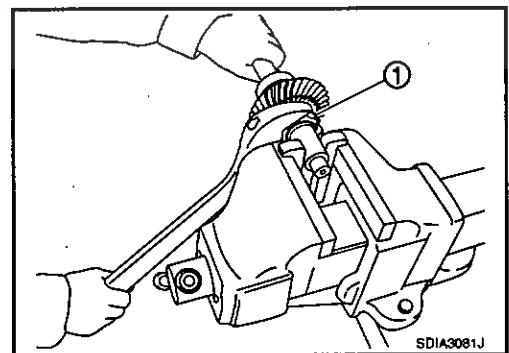

8. Remove ring gear from ring gear shaft with a drift (A) (SST: ST33052000).

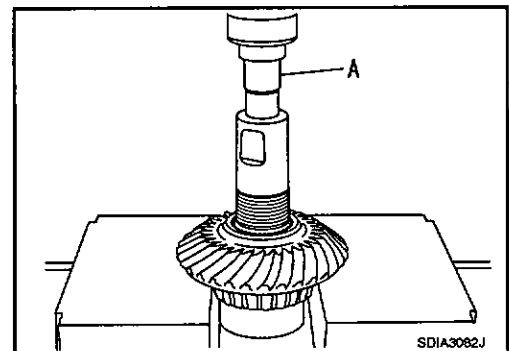

A
B
C
DLN
E
F
G
H
I
J
K
L
M
N
O
P

دیجیال خودرو
شرکت دیجیتال خودرو سامانه (مسئولیت محدود)
اولین سامانه دیجیتال تعمیرکاران خودرو در ایران

RING GEAR SHAFT

< DISASSEMBLY AND ASSEMBLY >

[TRANSFER: TY30A]

- Remove inner race of ring gear shaft bearing (adapter case side) from ring gear with a drift (A) (commercial service tool) and replacer.

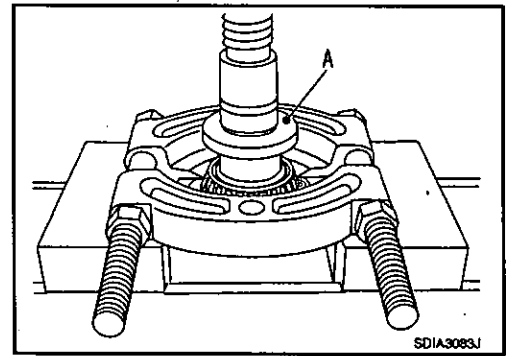

INFOID:000000004805452

M/T : Assembly

- Select ring gear adjusting shim (transfer case side). Refer to DLN-73. "M/T : Adjustment".
- Assemble the selected ring gear adjusting shim (transfer case side) and outer races of ring gear shaft bearing (transfer case side) to the transfer case.

CAUTION:

- Never reuse ring gear shaft bearing (transfer case side).
- Apply gear oil to the ring gear shaft bearing (transfer case side).

- Select ring gear adjusting shim (adapter case side). Refer to DLN-73. "M/T : Adjustment".
- Install the selected ring gear adjusting shim (adapter case side) to the adapter case.

- Install outer race of ring gear shaft bearing (adapter case side) to the adapter case with a drift (A) (commercial service tool).

CAUTION:

- Never reuse ring gear shaft bearing (adapter case side).
- Apply gear oil to the ring gear shaft bearing (adapter case side).

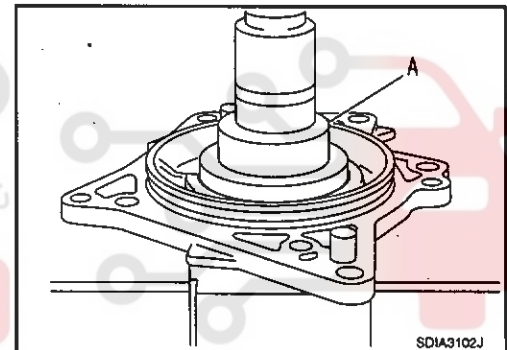

- Install inner race of ring gear shaft bearing (adapter case side) to the ring gear with drifts.

- A : Press adapter (If necessary)
- B : Drift (commercial service tool)

CAUTION:

- Never reuse ring gear shaft bearing (adapter case side).
- Apply gear oil to the ring gear shaft bearing (adapter case side).

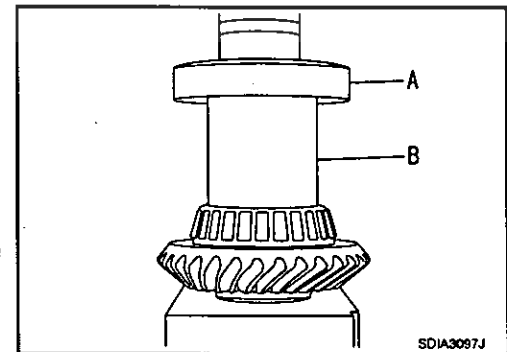

- Apply anti-corrosive oil to the spline of ring gear shaft. Install the ring gear to ring gear shaft with drifts.

- A : Drift (SST: ST01530000)
- B : Drift (SST: ST35272000)

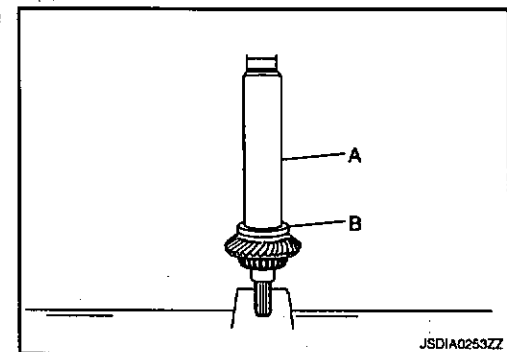

RING GEAR SHAFT

< DISASSEMBLY AND ASSEMBLY >

[TRANSFER: TY30A]

8. Apply anti-corrosive oil to threads and seats of ring gear nut. Tighten the ring gear nut with the specified torque by using a torque wrench.

CAUTION:

- Never reuse ring gear nut.
- Never damage ring gear shaft.

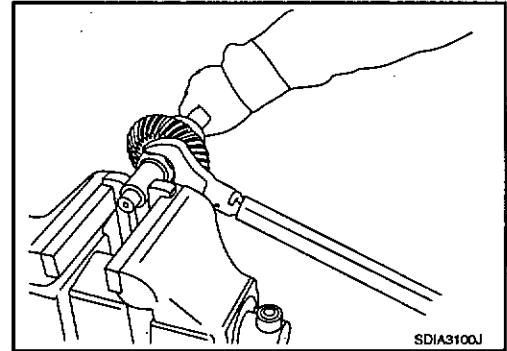

9. Install inner race of ring gear shaft bearing (transfer case side) to the ring gear shaft with a drift (A) (SST: KV10111400).

CAUTION:

- Never reuse ring gear shaft bearing (transfer case side).
- Apply gear oil to the ring gear shaft bearing (transfer case side).

10. Assemble the ring gear shaft assembly to the transfer case.

11. Install adapter case. Refer to DLN-57. "M/T : Assembly".

12. Check backlash, tooth contact, total preload and companion flange runout. Refer to DLN-73. "M/T : Adjustment".

CAUTION:

Measure the total preload without the adapter case oil seal.

13. Install adapter case oil seal (outer/inner) to the adapter case. Refer to DLN-57. "M/T : Assembly".

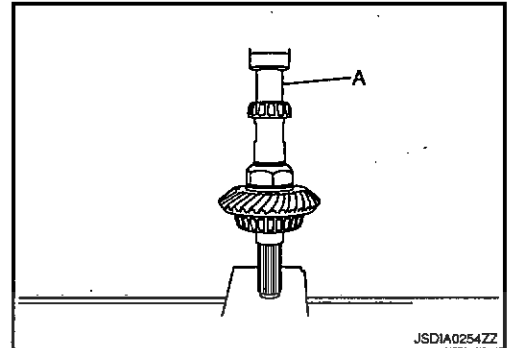

M/T : Inspection After Disassembly

INFOID:000000004905453

Check items below. If necessary, replace them with new ones.

GEAR AND SHAFT

Check gear face and shaft for wear, cracks, damage, and seizure.

CAUTION:

Replace ring gear and drive pinion as a set (hypoid gear set) if any malfunction is detected on the ring gear or drive pinion.

BEARING

Check for seizure, peeling, wear, corrosion, sticking, unusual noise, roughness in hand turning, and other damage.

CAUTION:

Always replace inner race and outer race as a pair when replacing the bearing.

SHIM

Check for seizure, damage, and unusual wear.

CASE

Check the bearing mounting surface for wear, cracks and damages.

CVT

RING GEAR SHAFT

< DISASSEMBLY AND ASSEMBLY >

[TRANSFER: TY30A]

CVT : Exploded View

INFOID:000000004905454

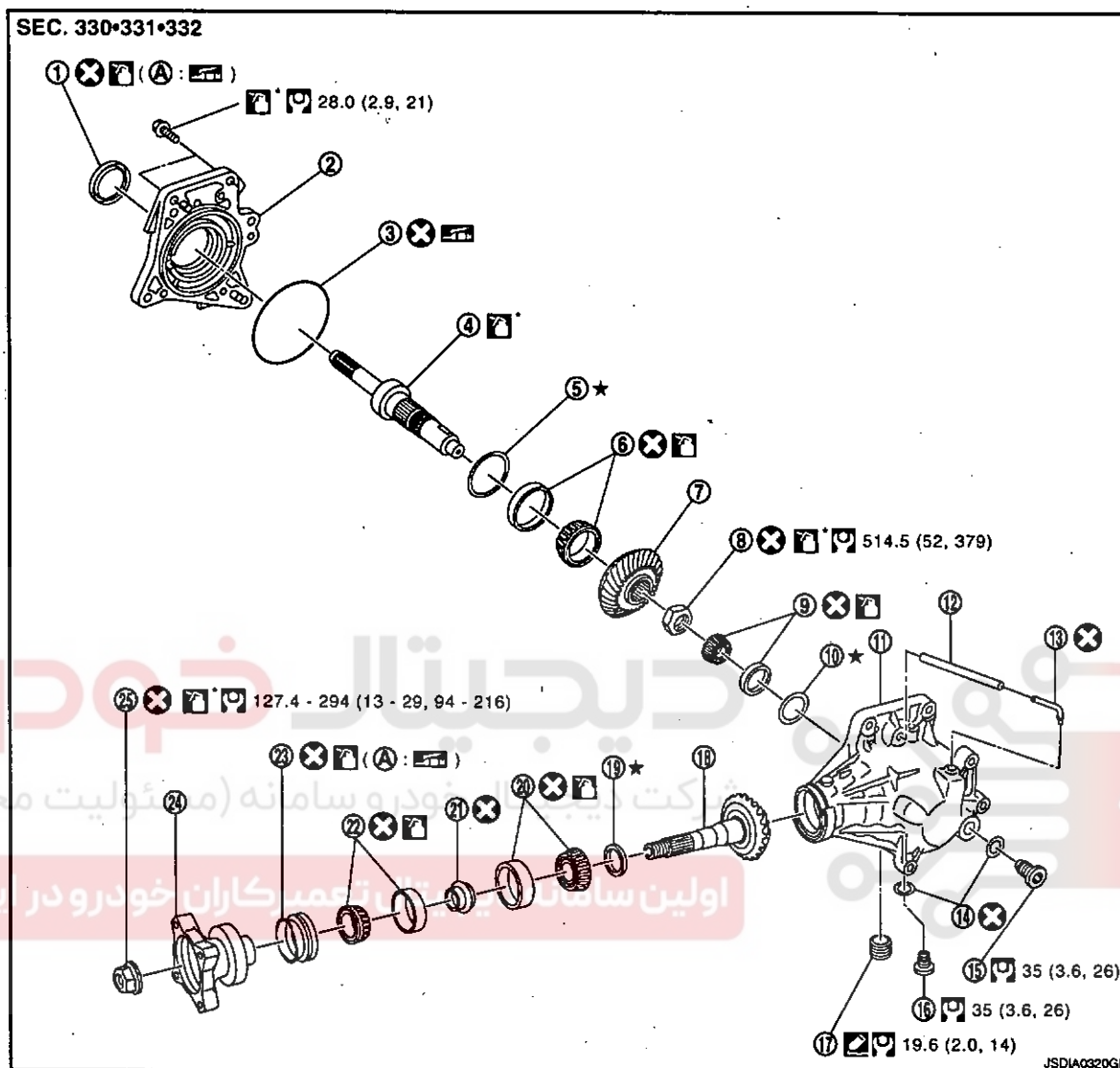

- | | | |
|---|---|---|
| 1. Adapter case oil seal | 2. Adapter case | 3. O-ring |
| 4. Ring gear shaft | 5. Ring gear adjusting shim (adapter case side) | 6. Ring gear shaft bearing (adapter case side) |
| 7. Ring gear | 8. Ring gear nut | 9. Ring gear shaft bearing (transfer case side) |
| 10. Ring gear adjusting shim (transfer case side) | 11. Transfer case | 12. Air breather hose |
| 13. Air breather tube | 14. Gasket | 15. Filler plug |
| 16. Drain plug | 17. Plug | 18. Drive pinion |
| 19. Drive pinion adjusting shim | 20. Drive pinion bearing (front side) | 21. Collapsible spacer |
| 22. Drive pinion bearing (rear side) | 23. Drive pinion oil seal | 24. Companion flange |
| 25. Lock nut | | |

A: Oil seal lip

: Apply gear oil.

: Apply multi-purpose grease.

: Apply anti-corrosive oil.

RING GEAR SHAFT

< DISASSEMBLY AND ASSEMBLY >

[TRANSFER: TY30A]

: Apply Genuine Liquid Gasket, Three Bond 1215 or equivalent.
Refer to GI-3, "Components" for symbols not described on the above.

CVT : Disassembly

INFOID:000000004905455

1. Remove adapter case. Refer to DLN-60, "CVT : Disassembly".
2. Remove adapter case oil seal from the adapter case. Refer to DLN-60, "CVT : Disassembly".
3. Tap the ring gear adjusting shim from the cutout on the adapter case with a brass rod to remove ring gear shaft bearing outer race (adapter case side) and ring gear adjusting shim (adapter case side).

CAUTION:

Be careful not to damage adapter case.

4. Remove ring gear shaft assembly from the transfer case.
5. Remove outer race of ring gear shaft bearing (transfer case side) and ring gear adjusting shim (transfer case side) from the transfer case.

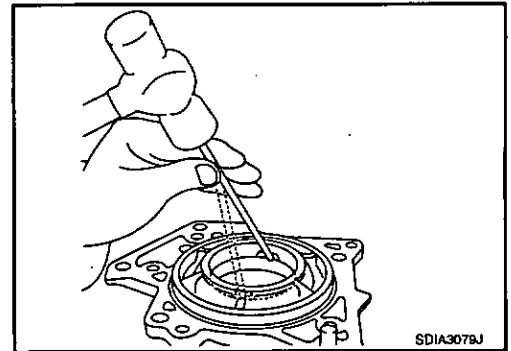

6. Remove inner race of ring gear shaft bearing (transfer case side) from ring gear shaft with drift (A) (commercial service tool) and replacer (B) (SST: ST22730000).

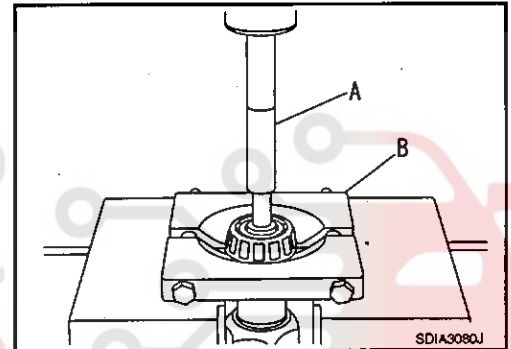

7. Remove ring gear nut (1).

CAUTION:

Never damage ring gear shaft.

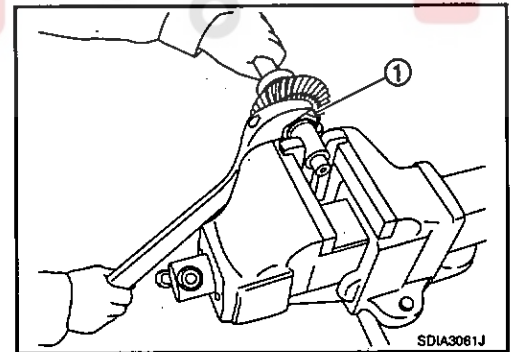

8. Remove ring gear from ring gear shaft with a drift (A) (SST: ST33052000).

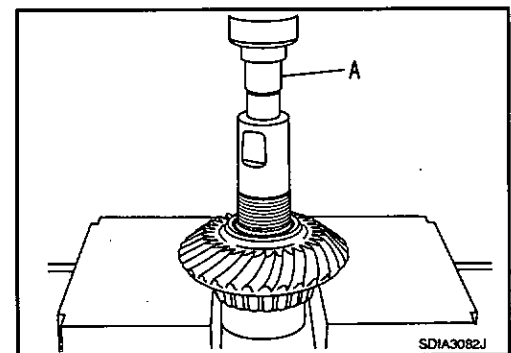

A
B
C
DLN
E
F
G
H
I
J
K
L
M
N
O
P

دیجیتال خودرو
شرکت دیجیتال خودرو سامانه (مسئولیت محدود)

اولین سامانه دیجیتال تعمیرکاران خودرو در ایران

RING GEAR SHAFT

< DISASSEMBLY AND ASSEMBLY >

[TRANSFER: TY30A]

9. Remove inner race of ring gear shaft bearing (adapter case side) from ring gear with a drift (A) (commercial service tool) and replacer.

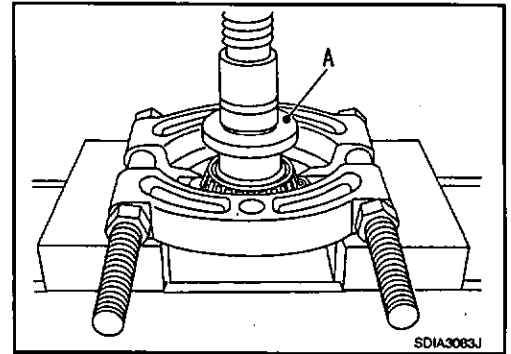

INFOID:000000004905456

CVT : Assembly

1. Select ring gear adjusting shim (transfer case side). Refer to DLN-86, "CVT : Adjustment".
2. Assemble the selected ring gear adjusting shim (transfer case side) and outer races of ring gear shaft bearing (transfer case side) to the transfer case.

CAUTION:

- Never reuse ring gear shaft bearing (transfer case side).
- Apply gear oil to the ring gear shaft bearing (transfer case side).

3. Select ring gear adjusting shim (adapter case side). Refer to DLN-86, "CVT : Adjustment".
4. Install the selected ring gear adjusting shim (adapter case side) to the adapter case.

5. Install outer race of ring gear shaft bearing (adapter case side) to the adapter case with a drift (A) (SST: ST30621000).

CAUTION:

- Never reuse ring gear shaft bearing (adapter case side).
- Apply gear oil to the ring gear shaft bearing (adapter case side).

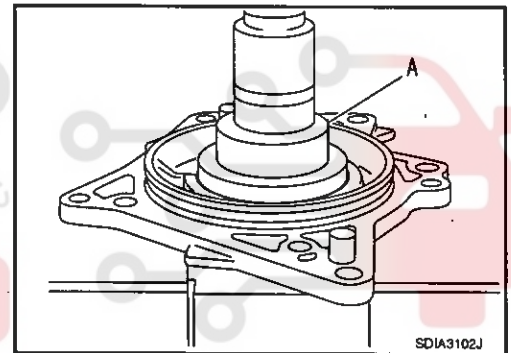

6. Install inner race of ring gear shaft bearing (adapter case side) to the ring gear with drifts.

- A : Press adapter (If necessary)
- B : Drift (commercial service tool)

CAUTION:

- Never reuse ring gear shaft bearing (adapter case side).
- Apply gear oil to the ring gear shaft bearing (adapter case side).

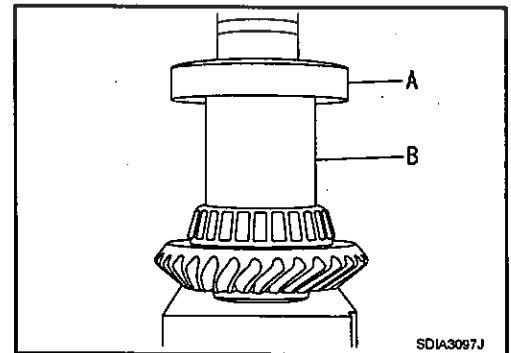

7. Apply anti-corrosive oil to the spline of ring gear shaft. Install the ring gear to ring gear shaft with drifts.

- A : Drift (SST: ST01530000)
- B : Drift (SST: ST35272000)

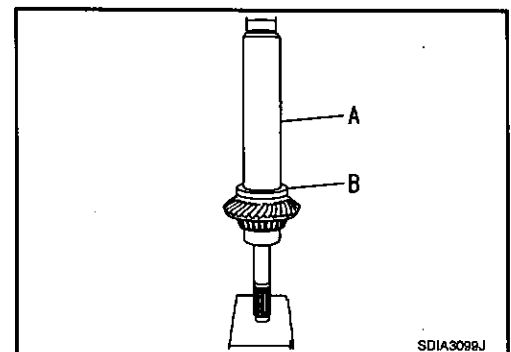

RING GEAR SHAFT

< DISASSEMBLY AND ASSEMBLY >

[TRANSFER: TY30A]

8. Apply anti-corrosive oil to threads and seats of ring gear nut. Tighten the ring gear nut with the specified torque by using a torque wrench.

CAUTION:

- Never reuse ring gear nut.
- Never damage ring gear shaft.

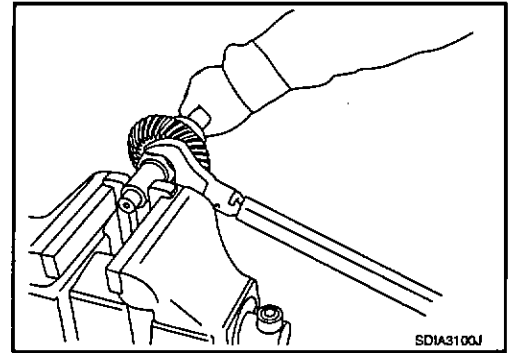

9. Install inner race of ring gear shaft bearing (transfer case side) to the ring gear shaft with a drift (A) (SST: KV10111400).

CAUTION:

- Never reuse ring gear shaft bearing (transfer case side).
- Apply gear oil to the ring gear shaft bearing (transfer race side).

10. Assemble the ring gear shaft assembly to the transfer case.

11. Install adapter case. Refer to DLN-60, "CVT : Assembly".

12. Check backlash, tooth contact, total preload and companion flange runout. Refer to DLN-86, "CVT : Adjustment".

CAUTION:

Measure the total preload without the adapter case oil seal.

13. Install adapter case oil seal to the adapter case. Refer to DLN-60, "CVT : Assembly".

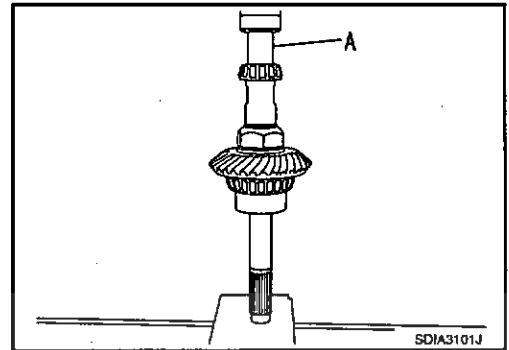

CVT : Inspection After Disassembly

(Check items below. If necessary, replace them with new ones.)

GEAR AND SHAFT

Check gear face and shaft for wear, cracks, damage, and seizure.

CAUTION:

Replace ring gear and drive pinion as a set (hypoid gear set) if any malfunction is detected on the ring gear or drive pinion.

BEARING

Check for seizure, peeling, wear, corrosion, sticking, unusual noise, roughness in hand turning, and other damage.

CAUTION:

Always replace inner race and outer race as a pair when replacing the bearing.

SHIM

Check for seizure, damage, and unusual wear.

CASE

Check the bearing mounting surface for wear, cracks and damages.

A

B

C

DLN

E

F

G

H

I

J

K

L

M

N

O

P

DRIVE PINION

< DISASSEMBLY AND ASSEMBLY >

[TRANSFER: TY30A]

DRIVE PINION

M/T

M/T : Exploded View

INFOID:000000004905458

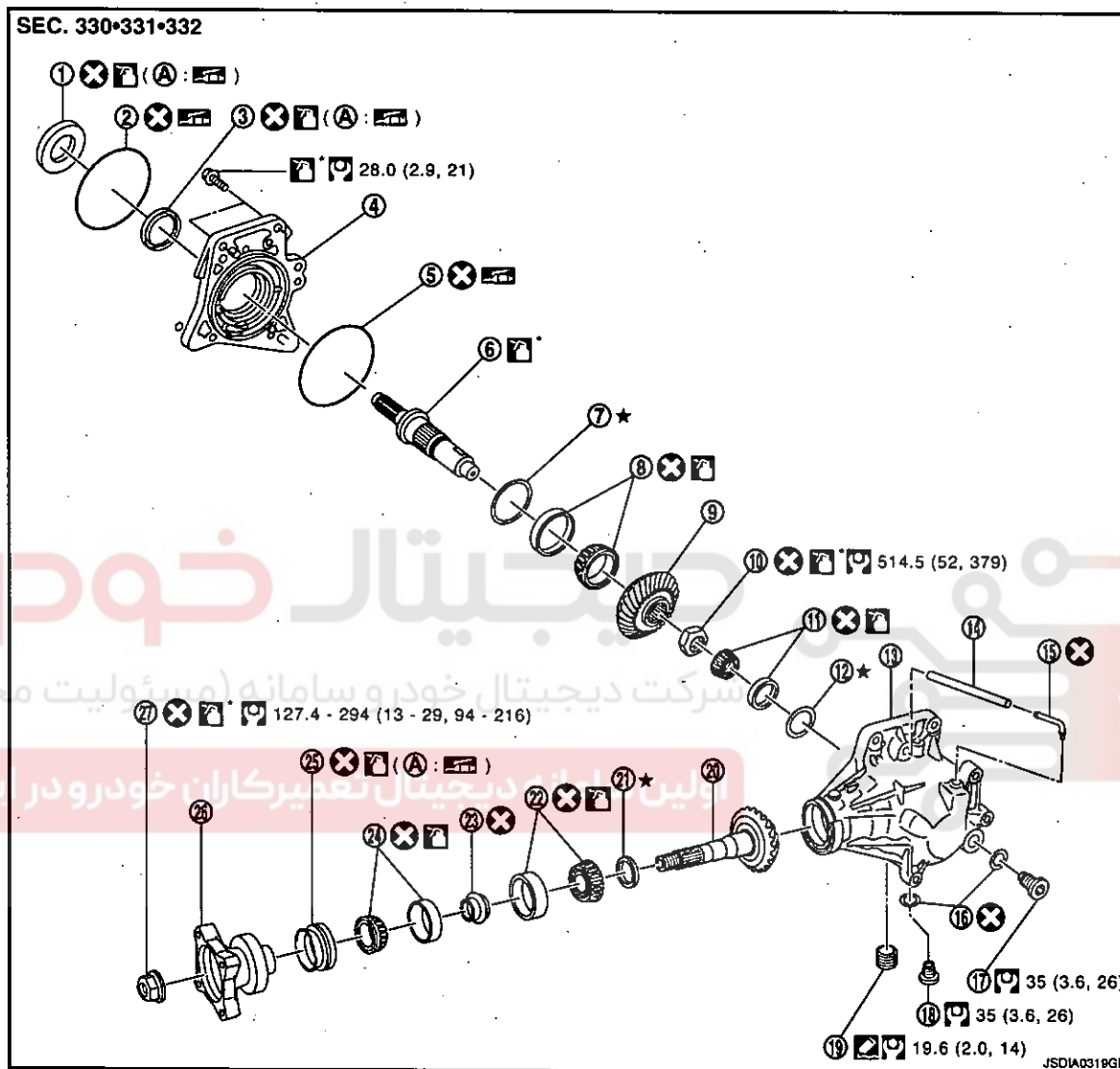

- | | | |
|---|--|---|
| 1. Adapter case oil seal (outer) | 2. O-ring (outer) | 3. Adapter case oil seal (inner) |
| 4. Adapter case | 5. O-ring (inner) | 6. Ring gear shaft |
| 7. Ring gear adjusting shim (adapter case side) | 8. Ring gear shaft bearing (adapter case side) | 9. Ring gear |
| 10. Ring gear nut | 11. Ring gear shaft bearing (transfer case side) | 12. Ring gear adjusting shim (transfer case side) |
| 13. Transfer case | 14. Air breather hose | 15. Air breather tube |
| 16. Gasket | 17. Filler plug | 18. Drain plug |
| 19. Plug | 20. Drive pinion | 21. Drive pinion adjusting shim |
| 22. Drive pinion bearing (front side) | 23. Collapsible spacer | 24. Drive pinion bearing (rear side) |
| 25. Drive pinion oil seal | 26. Companion flange | 27. Lock nut |

A: Oil seal lip

: Apply gear oil.

: Apply multi-purpose grease.

DRIVE PINION

< DISASSEMBLY AND ASSEMBLY >

[TRANSFER: TY30A]

 : Apply anti-corrosive oil.

 : Apply Genuine Liquid Gasket, Three Bond 1215 or an equivalent.
Refer to GI-3, "Components" for symbols not described on the above.

M/T : Disassembly

INFOID:000000004905459

1. Remove adapter case. Refer to DLN-57, "M/T : Disassembly".
2. Remove ring gear shaft assembly. Refer to DLN-63, "M/T : Disassembly".
3. Remove lock nut from the drive pinion.
4. Put matching marks (A) on screw ends of companion flange (1) and drive pinion.
CAUTION:
Use paint to avoid scratching the surface.

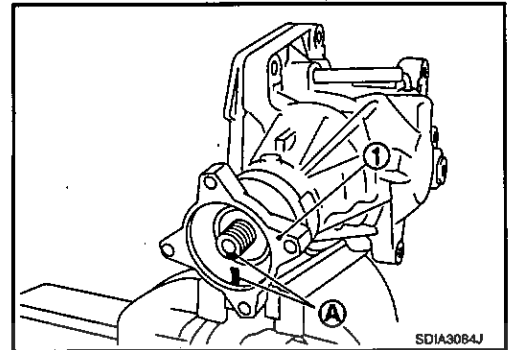

5. Remove companion flange from drive pinion with a puller.

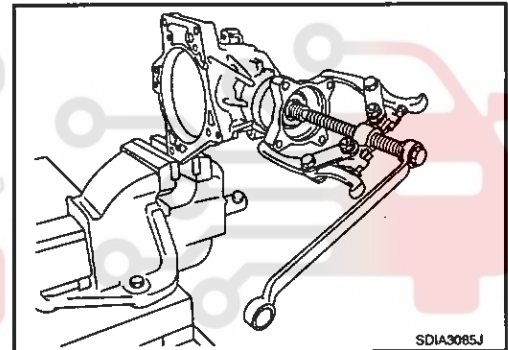

6. Remove drive pinion oil seal from the transfer case with a puller (A) (SST: KV381054S0).
CAUTION:
Never damage transfer case.

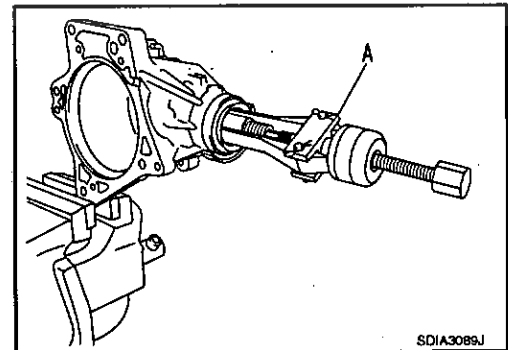

7. Remove drive pinion assembly from transfer case while tapping the drive pinion lightly with a plastic hammer.
CAUTION:
Never drop the drive pinion assembly.
8. Remove collapsible spacer from the drive pinion.
9. Remove inner race of drive pinion bearing (rear side) from transfer case.

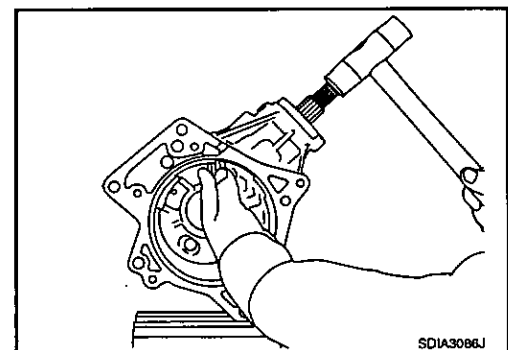

A
B
C
DLN
E
F
G
H
I
J
K
L
M
N
O
P

دیجیتال خودرو
شرکت دیجیتال خودرو سامانه (مسئولیت محدود)
اولین سامانه دیجیتال تعمیرکاران خودرو در ایران

DRIVE PINION

< DISASSEMBLY AND ASSEMBLY >

[TRANSFER: TY30A]

10. Remove inner race of drive pinion bearing (front side) from drive pinion with a drift (A) (SST: ST33052000) and replacer (B) (SST: ST22730000).
11. Remove drive pinion adjusting shim from the drive pinion.

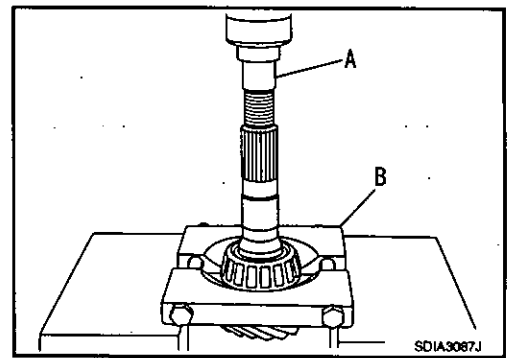

INFOID:000000004905460

M/T : Assembly

1. Select drive pinion adjusting shim. Refer to DLN-73, "M/T : Adjustment".
2. Install selected drive pinion adjusting shim to drive pinion.
3. Install inner race of drive pinion bearing (front side) to drive pinion with a drift (A) (SST: ST23860000).
CAUTION:
 - Never reuse drive pinion bearing (front side).
 - Apply gear oil to the drive pinion bearing (front side).
4. Assemble the inner race of drive pinion bearing (rear side) into the transfer case.
CAUTION:
 - Never reuse drive pinion bearing (rear side).
 - Apply gear oil to the drive pinion bearing (rear side).

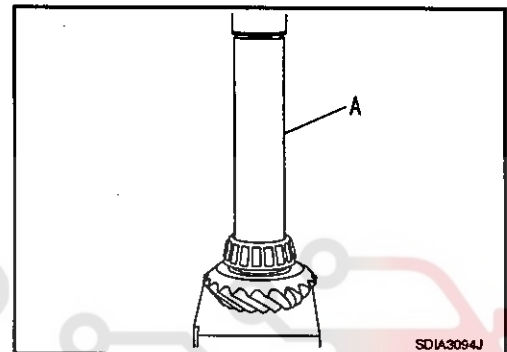

5. Install drive pinion oil seal to transfer case with drifts so that it becomes flush with case end surface.

A : Drift (SST: ST27861000)
B : Drift (SST: ST30720000)

CAUTION:

- Never reuse oil seal.
- Apply multi-purpose grease onto oil seal lips, and gear oil onto the circumference.

6. Assemble a collapsible spacer onto the drive pinion.

CAUTION:

Never reuse the collapsible spacer.

7. Assemble drive pinion assembly into the transfer case, and then install companion flange (1) to drive pinion.

NOTE:

Align matching marks (A) on the thread edge of companion flange and drive pinion and install companion flange if drive pinion is reused.

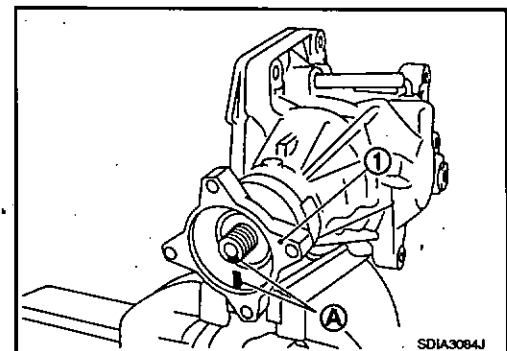
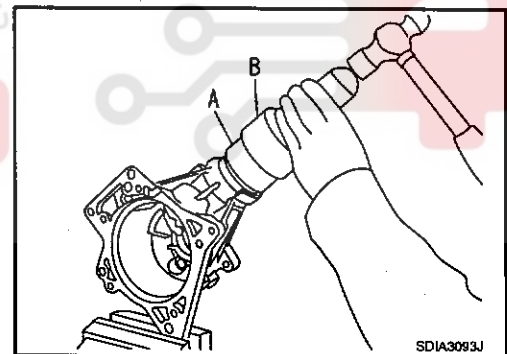

DRIVE PINION

[TRANSFER: TY30A]

< DISASSEMBLY AND ASSEMBLY >

8. Tap the companion flange with a plastic hammer as far as the lock nut can be tightened.
CAUTION:
Never damage drive pinion oil seal.
9. Apply anti-corrosive oil to the thread and seat of the lock nut, and temporarily tighten lock nut to the drive pinion.
CAUTION:
Never reuse lock nut.

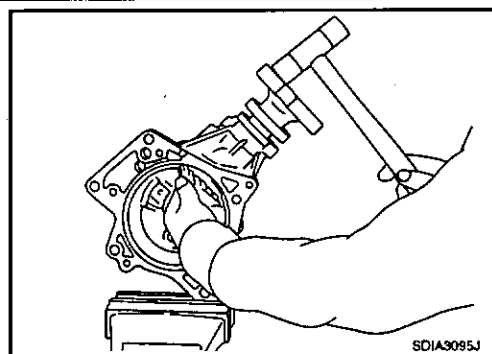

10. Tighten lock nut within the specified torque range with a preload gauge (A) (SST: ST3127S000) so that the drive pinion bearing preload is within standard.

Standard

Drive pinion bearing preload : Refer to DLN-102. "Pre-load Torque".

CAUTION:

- Start the tightening of lock nut from lower limit of the specified torque. Check the preload every 5° to 10° while tightening the lock nut.
- Replace the collapsible spacer and tighten it again to adjust if preload exceeds the specified value. Never loosen lock nut to adjust preload.
- After adjustment, rotate the drive pinion back and forth from 2 to 3 times to check for unusual noise, sticking, binding, and so on.

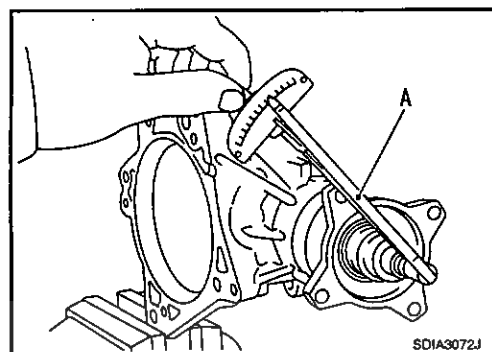

11. Install ring gear shaft assembly. Refer to DLN-64. "M/T : Assembly".
12. Install adapter case. Refer to DLN-57. "M/T : Assembly".
13. Check backlash, tooth contact, total preload and companion flange runout. Refer to DLN-73. "M/T : Adjustment".

CAUTION:
Measure the total preload without the adapter case oil seal.

M/T : Adjustment

INFOID:000000004905461

BACKLASH

1. Install the bolt (A) to the companion flange.
2. Fit a dial indicator onto the bolt.
3. Measure the circumference backlash of the companion flange.

Standard

Backlash : Refer to DLN-102. "Backlash".

Disassemble the transfer assembly to check and adjust each part if outside the standard.

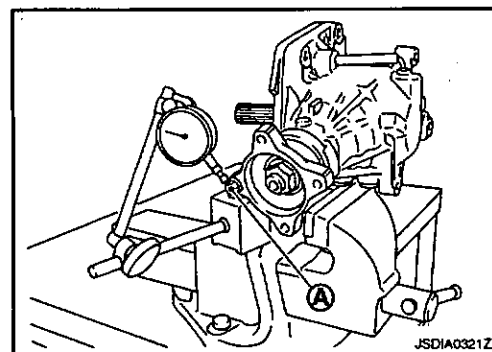

TOOTH CONTACT

1. Remove adapter case. Refer to DLN-57. "M/T : Disassembly".

A
B
C
DLN
E
F
G
H
I
J
K
L
M
N
O
P

DRIVE PINION

< DISASSEMBLY AND ASSEMBLY >

[TRANSFER: TY30A]

2. Remove ring gear shaft assembly from transfer case. Then apply red lead onto the ring gear.
CAUTION:
Apply red lead to both faces of 3 to 4 gears at 4 locations evenly spaced on the ring gear.
3. Assemble the ring gear shaft assembly to the transfer case.
4. Install adapter case. Refer to DLN-57, "M/T : Assembly".
5. Remove plug on the lower side of the transfer case.

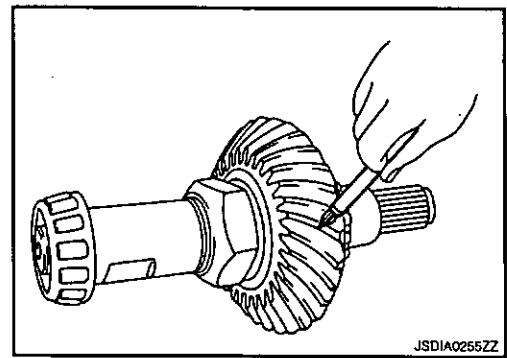

6. Rotate the companion flange back and forth several times. Then check drive pinion to ring gear tooth contact by viewing from the tooth contact test hole. (A: Drive side, B: Reverse side)

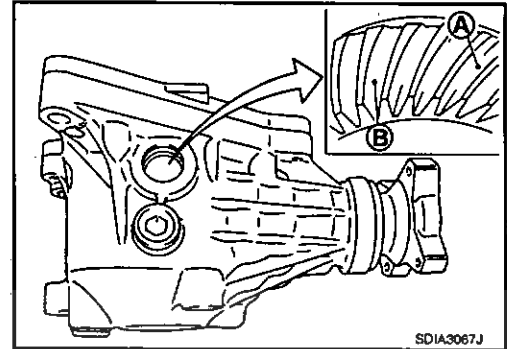

Tooth Contact Judgment Guide

Drive pinion adjusting shim selection value mm (in)		Tooth contact condition		Need for adjustment
		Drive side	Back	
Thicker ↑	+0.12 (+0.0047)	Heel side	Toe side	Yes
	+0.09 (+0.0035)			
	+0.06 (+0.0024)			
	+0.03 (+0.0012)			
	0 (0.0)			
Thinner ↓	-0.03 (-0.0012)			No
	-0.06 (-0.0024)			
	-0.09 (-0.0035)			
	-0.12 (-0.0047)			

JSDIA0213GB

DRIVE PINION

[TRANSFER: TY30A]

< DISASSEMBLY AND ASSEMBLY >

- 7. Follow the procedure below to adjust pinion height (dimension X) if tooth contact is improper.
CAUTION:
If no adjusting shim with the calculated value is available, select the thicker and closest one.

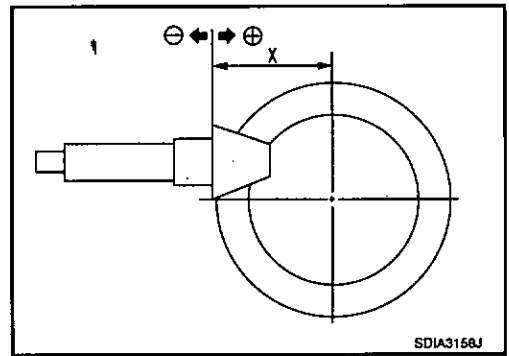

- Thicken the drive pinion adjusting shim to move the drive pinion closer to the ring gear in case of face contact or heel contact.
CAUTION:
Only one adjusting shim can be selected.

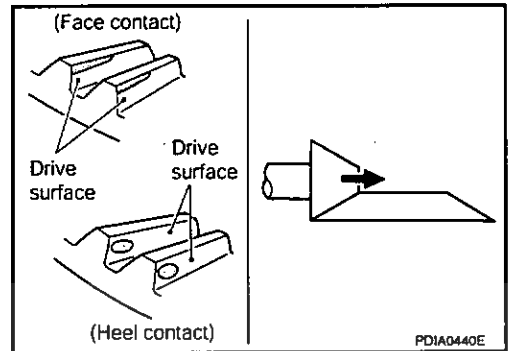

- Thin the drive pinion adjusting shim to move the drive pinion farther from the ring gear in case of flank contact or toe contact.
CAUTION:
Only one adjusting shim can be selected.

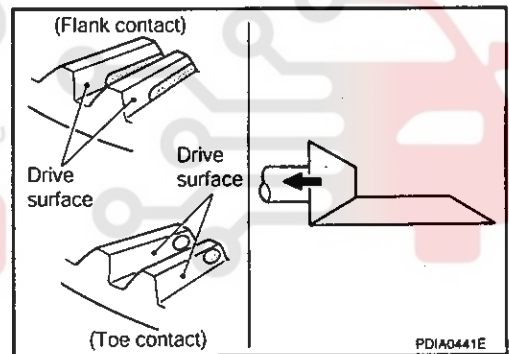

- 8. Assemble the plug to the transfer case.
CAUTION:
 - Remove old gasket on mounting surface, then remove any moisture, oil, and foreign material on the application and mounting surfaces.
 - Apply liquid gasket to the thread, and tighten to the specified torque when installing plug.

DRIVE PINION BEARING PRELOAD

1. Remove adapter case. Refer to DLN-57. "M/T : Disassembly".
2. Remove ring gear shaft assembly from the transfer case.
3. Rotate the companion flange back and forth from 2 to 3 times to check for unusual noise, binding, sticking, and so on.
4. Rotate the companion flange at least 20 times to check for smooth operation of the bearing.
5. Measure the drive pinion bearing preload with a preload gauge (A) (SST: ST3127S000).

Standard

Drive pinion bearing preload : Refer to DLN-102. "Preload Torque".

- CAUTION:**
Each rotational part should rotate smoothly with the specified gear oil.
 - Disassemble the drive pinion assembly to check and adjust each part if outside the standard.

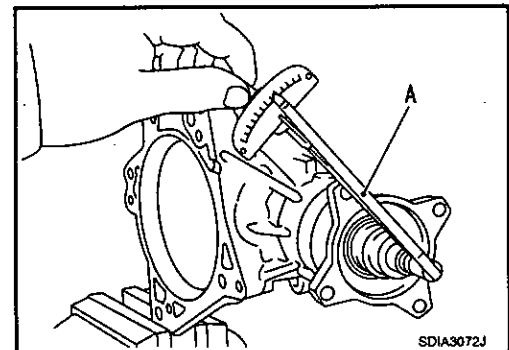

TOTAL PRELOAD

1. Measure drive pinion bearing preload (P1). Refer to "DRIVE PINION BEARING PRELOAD".

DRIVE PINION

< DISASSEMBLY AND ASSEMBLY >

[TRANSFER: TY30A]

CAUTION:**Check that the drive pinion bearing preload is within the standard.**

2. Assemble the ring gear shaft assembly to the transfer case.
3. Install adapter case. Refer to DLN-57: "M/T: Assembly".
4. Rotate the companion flange at least 20 times to check for smooth operation of the bearing.
5. Measure the total preload with a preload gauge (A) (SST: ST3127S000).

Standard**Total preload**

All oil seals are installed : Refer to DLN-102: "Preload Torque".

Without adapter case oil seal : Refer to DLN-102: "Preload Torque".

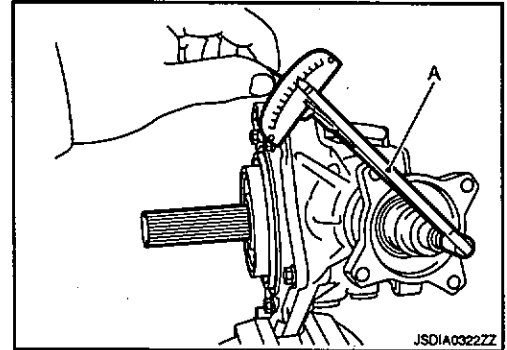
**CAUTION:**

- Each rotational part should rotate smoothly with the specified gear oil.
- Disassemble the transfer assembly to check and adjust each part if outside the standard. Measure it with the adapter case oil seals removed when measuring total preload after disassembly. Then install adapter case oil seals.

COMPANION FLANGE RUNOUT

1. Fit a dial indicator onto the companion flange face (inner side of the propeller shaft bolt holes).
2. Rotate the companion flange to check for runout.

Limit

Companion flange runout : Refer to DLN-102: "Companion Flange Runout".

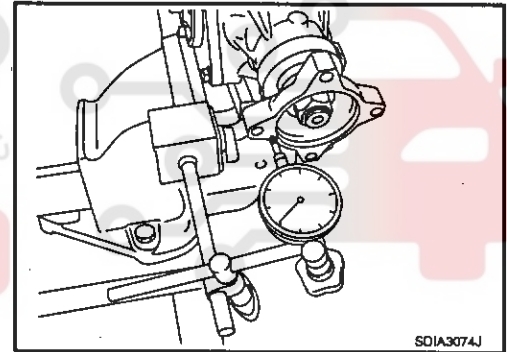

3. Fit a test indicator to the inner side of the companion flange (socket diameter).
4. Rotate the companion flange to check for runout.

Limit

Companion flange runout : Refer to DLN-102: "Companion Flange Runout".

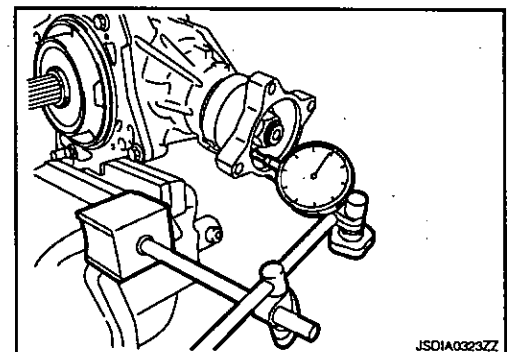

5. Follow the procedure below to adjust if runout value is outside the repair limit.

CAUTION:**Replace collapsible spacer to check and adjust each part when companion flange is adjusted or replaced.**

- a. Check for runout while changing the phase between companion flange and drive pinion in 90° steps. Then search for the minimum point.
- b. Replace companion flange if runout value is still outside the limit after the phase has been changed.
- c. Adjust assembly status of the drive pinion bearings and drive pinion, or replace drive pinion bearings if runout is outside the standard after the companion flange is replaced.

ADJUSTING SHIM SELECTION

Measuring Point

DRIVE PINION

< DISASSEMBLY AND ASSEMBLY >

[TRANSFER: TY30A]

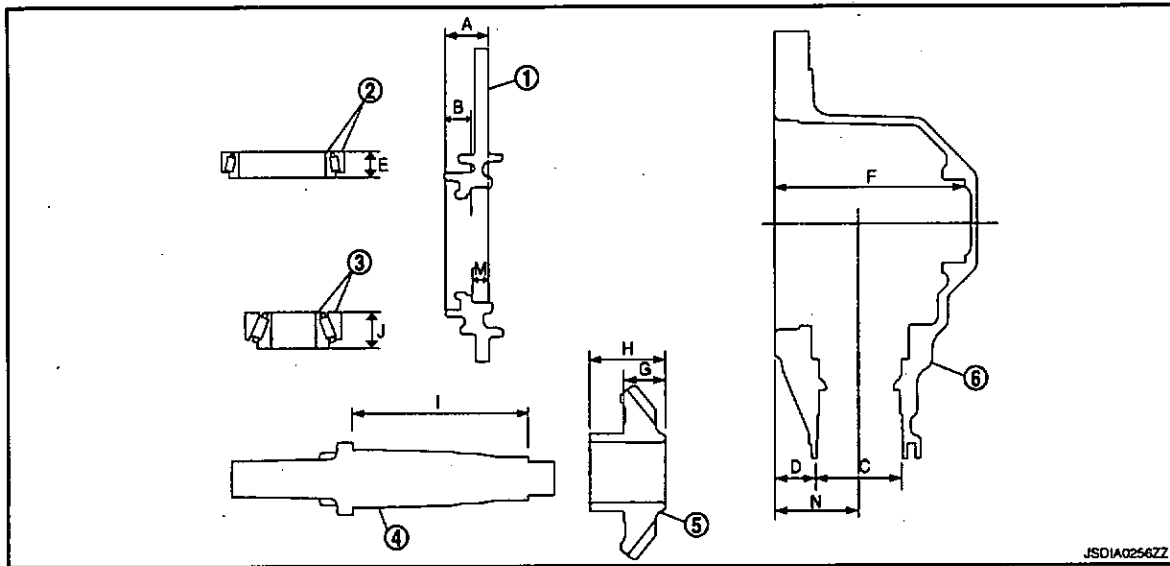

A
B
C
DLN
E
F
G
H
I
J
K
L
M
N
O
P

- | | | |
|--------------------|--|---|
| 1. Adapter case | 2. Ring gear shaft bearing (Adapter case side) | 3. Ring gear shaft bearing (Transfer case side) |
| 4. Ring gear shaft | 5. Ring gear | 6. Transfer case |

Ring Gear Adjusting Shim (Adapter Case Side)

1. Measure the dimensions of each measuring point with the following procedure:

Dimension "A" measurement

- Measure dimension from transfer case mounting surface of adapter case to adapter case edge surface with a pair of vernier calipers and straightedge. Refer to "Measuring point".

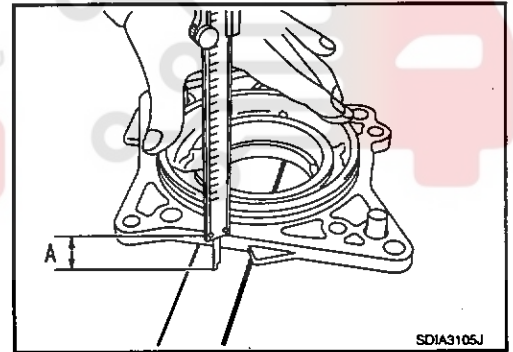

اولین سامانه دیجیتال تعمیرکاران خودرو در ایران

Dimension "B" measurement

- Measure dimension from ring gear adjusting shim mounting surface of adapter case to adapter case edge surface with a pair of vernier calipers and straightedge. Refer to "Measuring point".

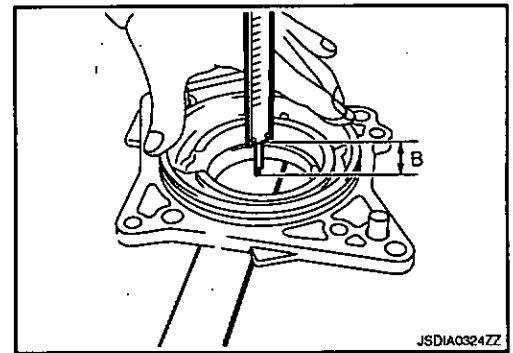

Dimension "C" measurement

DRIVE PINION

< DISASSEMBLY AND ASSEMBLY >

[TRANSFER: TY30A]

- Measure the diameter of drive pinion bearing (rear side) mounting area of transfer case with a pair of vernier calipers. Refer to "Measuring point".

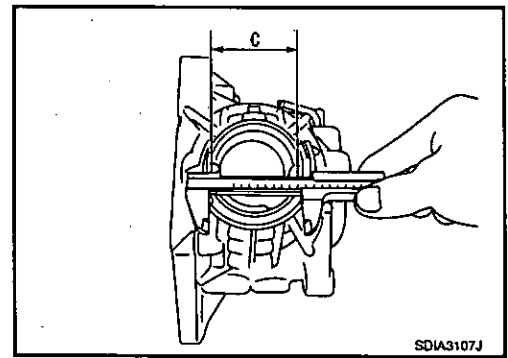
CAUTION:**Never damage transfer case.**

Dimension "D" measurement

- Measure dimension from adapter case mounting surface of transfer case to drive pinion bearing (rear side) mounting surface with a pair of vernier calipers and straightedge. Refer to "Measuring point".

CAUTION:

- **Never damage transfer case.**
- **Consider the thickness of a straightedge.**

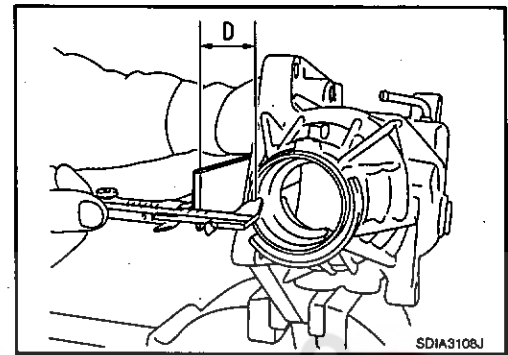

Dimension "E" measurement

- Measure dimension from outer race edge surface of ring gear shaft bearing (adapter case side) to inner race edge surface with a pair of vernier calipers. Refer to "Measuring point".

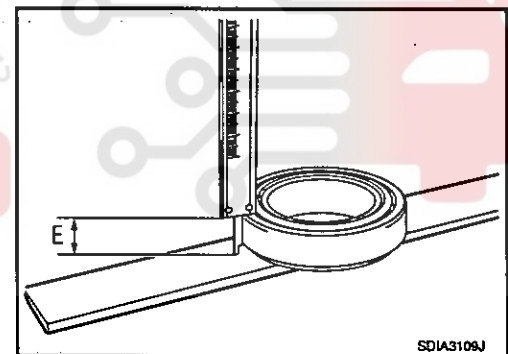

2. Calculate dimensions "M" and "N" by the formula below.

$$\text{Dimension "M"} = \text{"A"} - \text{"B"}$$

$$\text{Dimension "N"} = \text{"C"} \times 0.5 \text{ mm (0.020 in)} + \text{"D"}$$

3. Convert the dimensions "E", "M" and "N" according to the standards below.

"E" : Actual value regarding 20.00 mm (0.7874 in) as 0 in increments of 0.01 mm (0.0004 in).

"M" : Actual value regarding 13.90 mm (0.5472 in) as 0 in increments of 0.01 mm (0.0004 in).

"N" : Actual value regarding 55.00 mm (2.1654 in) as 0 in increments of 0.01 mm (0.0004 in).

DRIVE PINION

< DISASSEMBLY AND ASSEMBLY >

[TRANSFER: TY30A]

4. Check dimension "Z" (machining difference) on the ring gear back surface.

NOTE:

Dimension "Z" indicates difference between optimum engagement and the standard dimensions in increments of 0.01 mm (0.0004 in) written on the ring gear back surface.

5. Calculate the thickness of the ring gear adjusting shim (adapter case side) "T1" by the formula below.

$$"T_1" = ("M" + "N" - "E" - "Z") \times 0.01 \text{ mm (0.0004 in)} + 1.40 \text{ mm (0.0551 in)}$$

6. Select ring gear adjusting shim (adapter case side).

CAUTION:

- Only one adjusting shim can be selected.
- Select the closest one, favoring thicker over thinner when necessary if no adjusting shim with the calculated value is available.

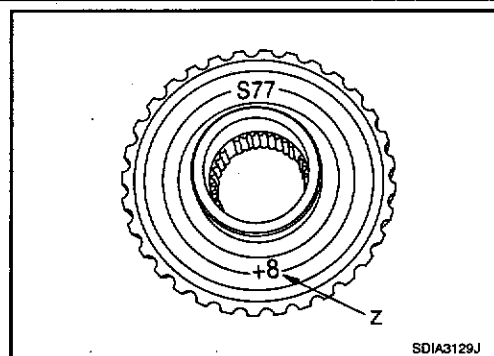

A
B
C

DLN

Ring Gear Adjusting Shim (Transfer Case Side)

1. Measure the dimensions of each measuring point with the following procedure:

Dimension "C" measurement

- Measure the diameter of drive pinion bearing (rear side) mounting area of transfer case with a pair of vernier calipers. Refer to "Measuring point".

CAUTION:

- Never damage transfer case.

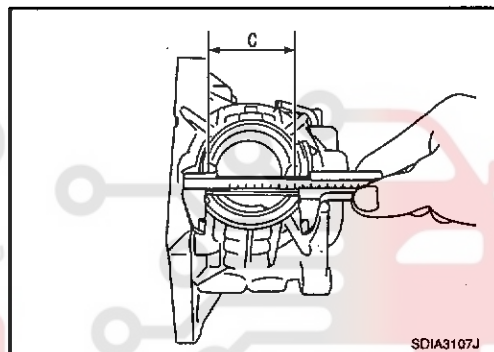

E
F

G

H

I

J

Dimension "D" measurement

- Measure dimension from adapter case mounting surface of transfer case to drive pinion bearing (rear side) mounting surface with a pair of vernier calipers and straightedge. Refer to "Measuring point".

CAUTION:

- Never damage transfer case.
- Consider the thickness of a straightedge.

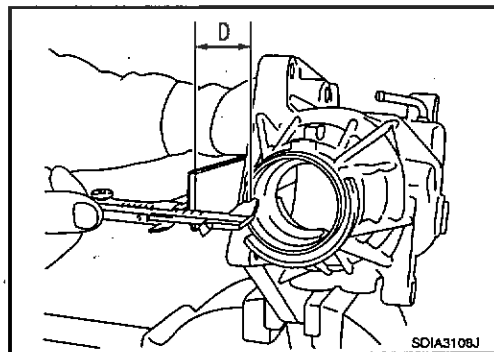

K

L

M

N

Dimension "F" measurement

- Measure dimension from adapter case mounting surface of transfer case to ring gear adjusting shim mounting surface with a depth gauge. Refer to "Measuring point".

CAUTION:

- Never damage transfer case.

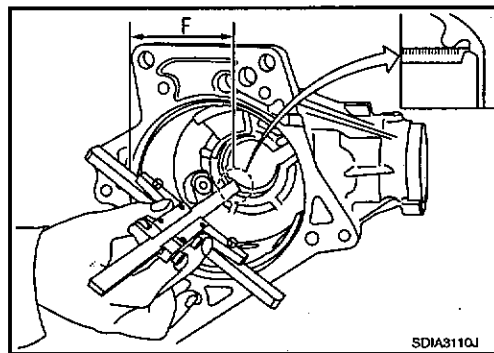

O

P

DRIVE PINION

< DISASSEMBLY AND ASSEMBLY >

[TRANSFER: TY30A]

Dimension "G" measurement

- Measure dimension from ring gear shaft bearing mounting surface of ring gear to transfer case side edge surface with a micrometer and straightedge. Refer to "Measuring point".

CAUTION:

Consider the thickness of a straightedge.

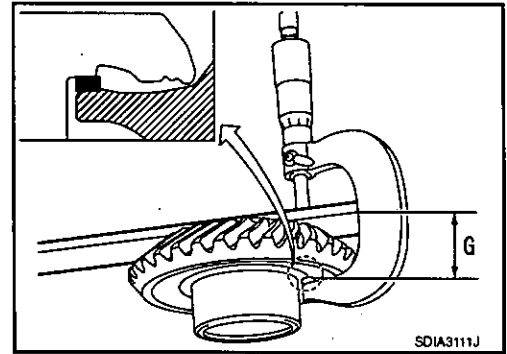

Dimension "H" measurement

- Measure dimension from transfer case side edge surface of ring gear to adapter case side edge surface with a pair of vernier calipers. Refer to "Measuring point".

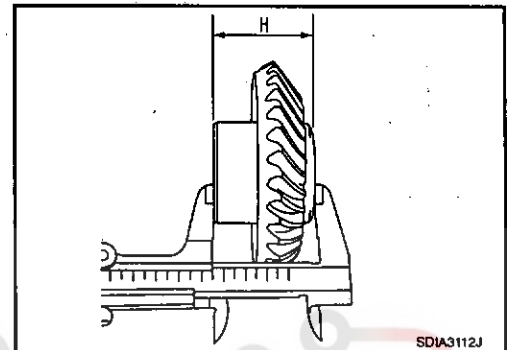

Dimension "I" measurement

- Measure dimension from ring gear mounting surface of ring gear shaft to ring gear shaft bearing (transfer case side) mounting surface with a pair of vernier calipers. Refer to "Measuring point".

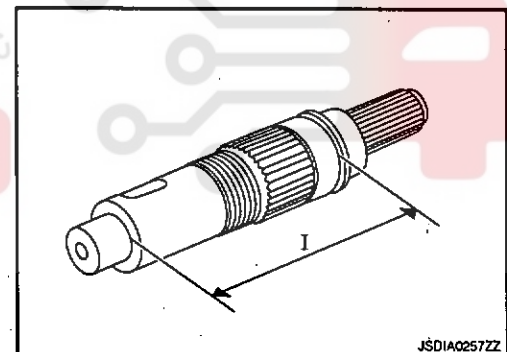

Dimension "J" measurement

- Measure dimension from outer race edge surface of ring gear shaft bearing (transfer case side) to inner race edge surface with a pair of vernier calipers. Refer to "Measuring point".

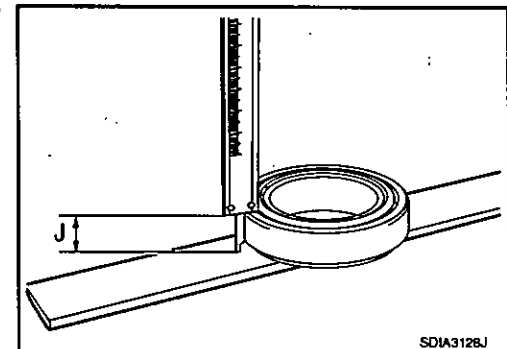

2. Calculate dimension "N" by the formula below.

$$\text{Dimension "N"} = \text{"C"} \times 0.5 \text{ mm (0.020 in)} + \text{"D"}$$

3. Convert the dimensions "F", "G", "H", "I", "J" and "N" according to the standards below.

DRIVE PINION

< DISASSEMBLY AND ASSEMBLY >

[TRANSFER: TY30A]

- "F" : Actual value regarding 122.60 mm (4.83 in) as 0 in increments of 0.01 mm (0.0004 in).
- "G" : Actual value regarding 26.60 mm (1.0472 in) as 0 in increments of 0.01 mm (0.0004 in).
- "H" : Actual value regarding 48.60 mm (1.9134 in) as 0 in increments of 0.01 mm (0.0004 in).
- "I" : Actual value regarding 119.40 mm (4.70 in) as 0 in increments of 0.01 mm (0.0004 in).
- "J" : Actual value regarding 16.25 mm (0.6398 in) as 0 in increments of 0.01 mm (0.0004 in).
- "N" : Actual value regarding 55.00 mm (2.1654 in) as 0 in increments of 0.01 mm (0.0004 in).

4. Check dimension "Z" (machining difference) on the ring gear back surface.

NOTE:

Dimension "Z" indicates difference between optimum engagement and the standard dimensions in increments of 0.01 mm (0.0004 in) written on the ring gear back surface.

5. Calculate the thickness of the ring gear adjusting shim (transfer case side) "T2" by the formula below.

$$"T_2" = ("F" - "G" + "H" - "I" - "J" - "N" + "Z") \times 0.01 \text{ mm (0.0004 in)} + 1.65 \text{ mm (0.0650 in)}$$

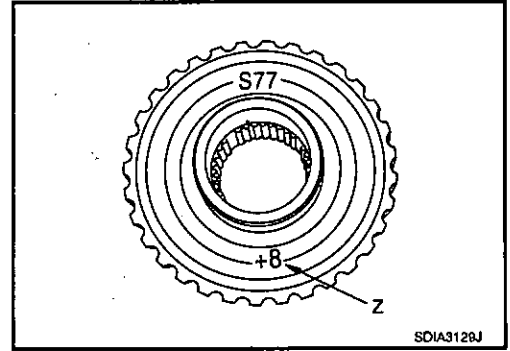

6. Select ring gear adjusting shim (transfer case side).

CAUTION:

- Only one adjusting shim can be selected.
- Select the closest one, favoring thicker over thinner when necessary if no adjusting shim with the calculated value is available.

Drive Pinion Adjusting Shim

1. Check the dimension "U" (machining difference) between old and new drive pinions when hypoid gear set (drive pinion and ring gear) has been replaced.

(Assemble new drive pinion adjusting shims with the same thickness as the ones removed prior to disassembly or removed drive pinion adjusting shims when reusing the hypoid gear set.)

NOTE:

Dimension "U" indicates the difference between optimum engagement and the standard dimensions in increments of 0.01 mm (0.0004 in). It is written on the gear end of the drive pinion for reference.

2. Calculate the thickness of the drive pinion adjusting shim "T" by the formula below.

$$"T" = T_0 + [(t_1 - t_2) \times 0.01 \text{ mm (0.0004 in)}]$$

"T" : Thickness of new shim

T₀ : Thickness of old shim

t₁ : Dimension "U" displayed on the gear end of old drive pinion

t₂ : Dimension "U" displayed on the gear end of new drive pinion

[Example]

$$"T" = 3.21 + [(2 + 1) \times 0.01 \text{ mm (0.0004 in)}]$$

T₀ : 3.21

t₁ : +2

t₂ : -1

3. Select drive pinion adjusting shim.

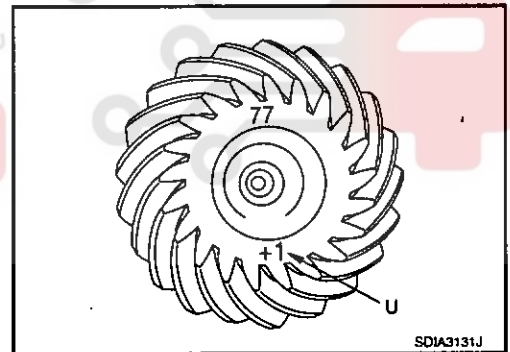

DRIVE PINION

< DISASSEMBLY AND ASSEMBLY >

[TRANSFER: TY30A]

CAUTION:

- Only one adjusting shim can be selected.
- Select the closest one, if no adjusting shim with the calculated value is available.

M/T : Inspection After Disassembly

INFOID:000000004905462

Check items below. If necessary, replace them with new ones.

GEAR AND SHAFT

Check gear face and shaft for wear, cracks, damage, and seizure.

CAUTION:

Replace ring gear and drive pinion as a set (hypoid gear set) if any malfunction is detected on the ring gear or drive pinion.

BEARING

Check for seizure, peeling, wear, corrosion, sticking, unusual noise, roughness in hand turning, and other damage.

CAUTION:

Always replace inner race and outer race as a pair when replacing the bearing.

SHIM

Check for seizure, damage, and unusual wear.

CASE

Check the bearing mounting surface for wear, cracks and damages.

CVT

دیجیتال خودرو

شرکت دیجیتال خودرو سامانه (مسئولیت محدود)

اولین سامانه دیجیتال تعمیرکاران خودرو در ایران



DRIVE PINION

< DISASSEMBLY AND ASSEMBLY >

[TRANSFER: TY30A]

CVT : Exploded View

INFOID:000000004995463

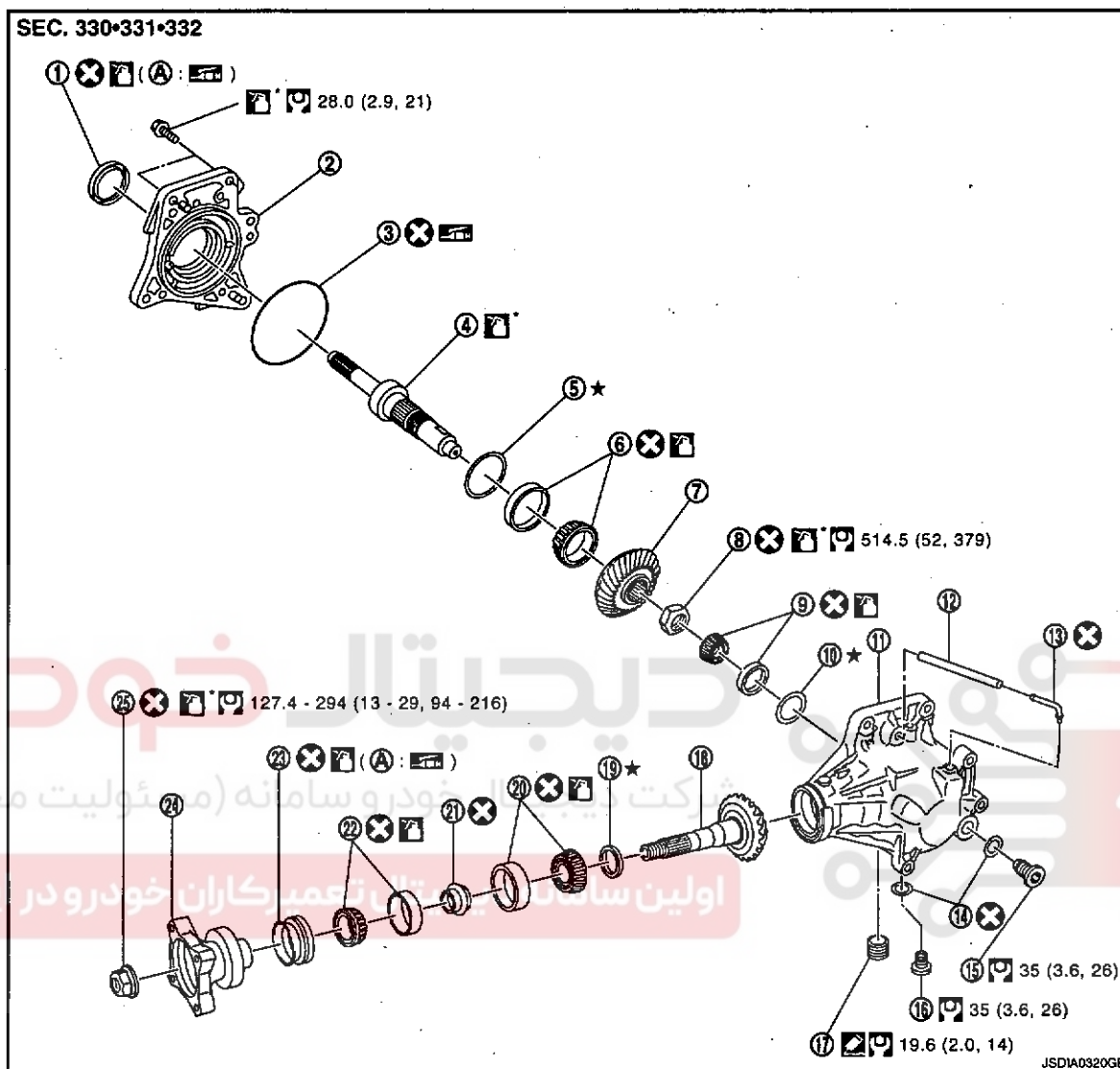

- | | | |
|---|---|---|
| 1. Adapter case oil seal | 2. Adapter case | 3. O-ring |
| 4. Ring gear shaft | 5. Ring gear adjusting shim (adapter case side) | 6. Ring gear shaft bearing (adapter case side) |
| 7. Ring gear | 8. Ring gear nut | 9. Ring gear shaft bearing (transfer case side) |
| 10. Ring gear adjusting shim (transfer case side) | 11. Transfer case | 12. Air breather hose |
| 13. Air breather tube | 14. Gasket | 15. Filler plug |
| 16. Drain plug | 17. Plug | 18. Drive pinion |
| 19. Drive pinion adjusting shim | 20. Drive pinion bearing (front side) | 21. Collapsible spacer |
| 22. Drive pinion bearing (rear side) | 23. Drive pinion oil seal | 24. Companion flange |
| 25. Lock nut | | |
- A: Oil seal lip

- : Apply gear oil.
- : Apply multi-purpose grease.
- : Apply anti-corrosive oil.

A
B
C
DLN
E
F
G
H
I
J
K
L
M
N
O
P

DRIVE PINION

< DISASSEMBLY AND ASSEMBLY >

[TRANSFER: TY30AJ]

-  Apply Genuine Liquid Gasket, Three Bond 1215 or an equivalent.
Refer to GI-3, "Components" for symbols not described on the above.

CVT : Disassembly

INFOID:000000004905464

1. Remove adapter case. Refer to DLN-60, "CVT : Disassembly".
2. Remove ring gear shaft assembly. Refer to DLN-67, "CVT : Disassembly".
3. Remove lock nut from the drive pinion.
4. Put matching marks (A) on screw ends of companion flange (1) and drive pinion.

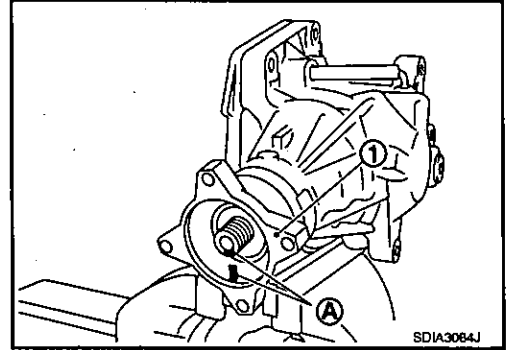
CAUTION:**Use paint to avoid scratching the surface.**

5. Remove companion flange from drive pinion with a puller.

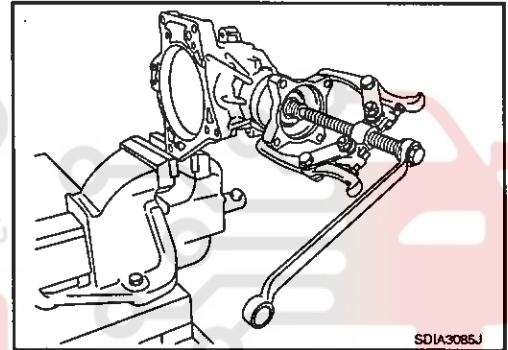

6. Remove drive pinion oil seal from the transfer case with a puller (A) (SST: KV381054S0).

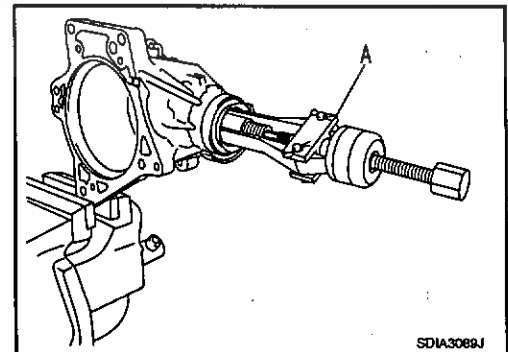
CAUTION:**Never damage transfer case.**

7. Remove drive pinion assembly from transfer case while tapping the drive pinion lightly with a plastic hammer.

CAUTION:**Never drop the drive pinion assembly.**

8. Remove collapsible spacer from the drive pinion.
9. Remove inner race of drive pinion bearing (rear side) from transfer case.

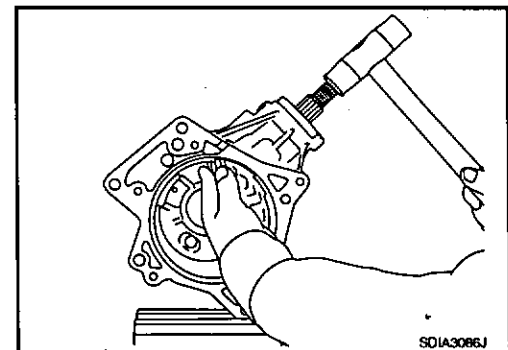

DRIVE PINION

< DISASSEMBLY AND ASSEMBLY >

[TRANSFER: TY30A]

10. Remove inner race of drive pinion bearing (front side) from drive pinion with a drift (A) (SST: ST33052000) and replacer (B) (SST: ST22730000).
11. Remove drive pinion adjusting shim from the drive pinion.

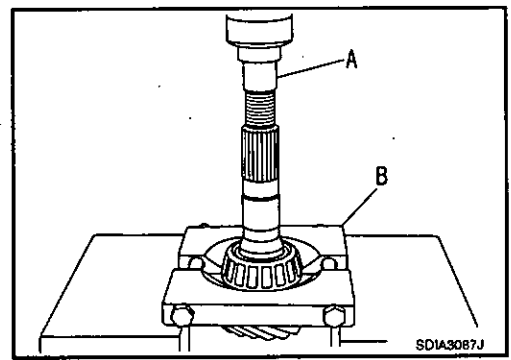

A
B
C

DLN

INFOID:000000004905465

CVT : Assembly

1. Select drive pinion adjusting shim. Refer to DLN-86, "CVT : Adjustment".
 2. Install selected drive pinion adjusting shim to drive pinion.
 3. Install inner race of drive pinion bearing (front side) to drive pinion with a drift (A) (SST: ST23860000).
- CAUTION:**
- Never reuse drive pinion bearing (front side).
 - Apply gear oil to the drive pinion bearing (front side).
4. Assemble the inner race of drive pinion bearing (rear side) into the transfer case.

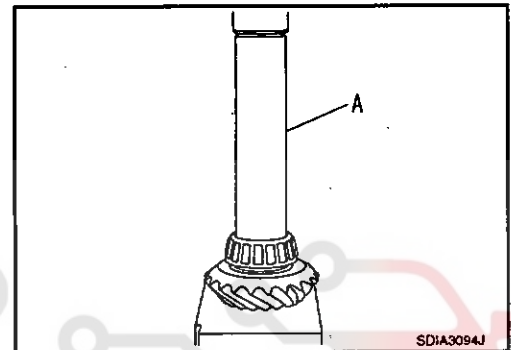

E
F
G
H

CAUTION:

- Never reuse drive pinion bearing (rear side).
- Apply gear oil to the drive pinion bearing (rear side).

5. Install drive pinion oil seal to transfer case with drifts so that it becomes flush with case end surface.

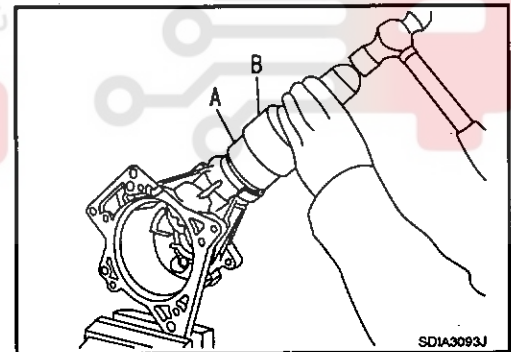

I
J
K
L

- A : Drift (SST: ST27861000)
B : Drift (SST: ST30720000)

CAUTION:

- Never reuse oil seal.
- Apply multi-purpose grease onto oil seal lips, and gear oil onto the circumference.

6. Assemble a collapsible spacer onto the drive pinion.

CAUTION:

Never reuse the collapsible spacer.

7. Assemble drive pinion assembly into the transfer case, and then install companion flange (1) to drive pinion.

NOTE:

Align matching marks (A) on the thread edge of companion flange and drive pinion and install companion flange if drive pinion is reused.

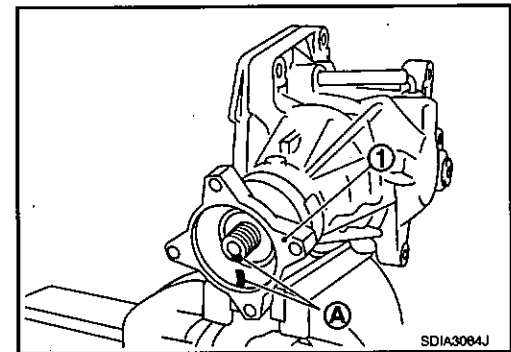

M
N
O
P

DRIVE PINION

< DISASSEMBLY AND ASSEMBLY >

[TRANSFER: TY30A]

8. Tap the companion flange with a plastic hammer as far as the lock nut can be tightened.

CAUTION:

Never damage drive pinion oil seal.

9. Apply anti-corrosive oil to the thread and seat of the lock nut, and temporarily tighten lock nut to the drive pinion.

CAUTION:

Never reuse lock nut.

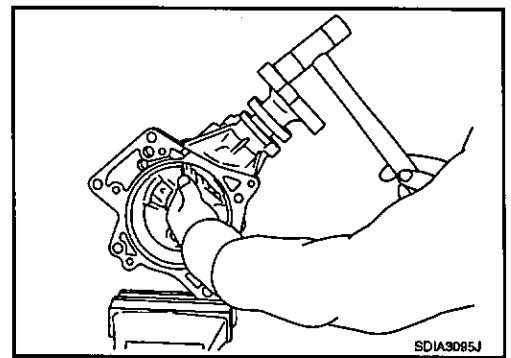

10. Tighten lock nut within the specified torque range with a preload gauge (A) (SST: ST3127S000) so that the drive pinion bearing preload is within standard.

Standard

Drive pinion bearing preload : Refer to DLN-102. "Pre-load Torque".

CAUTION:

- Start the tightening of lock nut from lower limit of the specified torque. Check the preload every 5° to 10° while tightening the lock nut.
- Replace the collapsible spacer and tighten it again to adjust if preload exceeds the specified value. Never loosen lock nut to adjust preload.
- After adjustment, rotate the drive pinion back and forth from 2 to 3 times to check for unusual noise, sticking, binding, and so on.

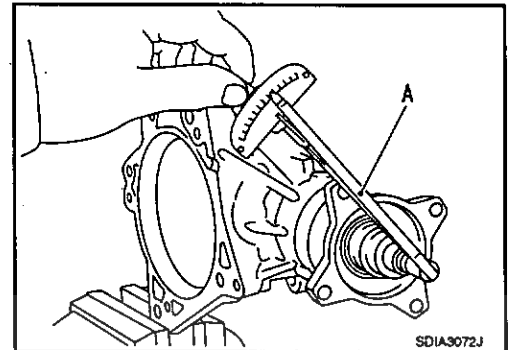

11. Install ring gear shaft assembly. Refer to DLN-68. "CVT : Assembly".

12. Install adapter case. Refer to DLN-60. "CVT : Assembly".

13. Check backlash, tooth contact, total preload and companion flange runout. Refer to DLN-86. "CVT : Adjustment".

CAUTION:

Measure the total preload without the adapter case oil seal.

CVT : Adjustment

INFOID:000000004905466

BACKLASH

1. Install the bolt (A) to the companion flange.
2. Fit a dial indicator onto the bolt.
3. Measure the circumference backlash of the companion flange.

Standard

Backlash : Refer to DLN-102. "Backlash".

Disassemble the transfer assembly to check and adjust each part if outside the standard.

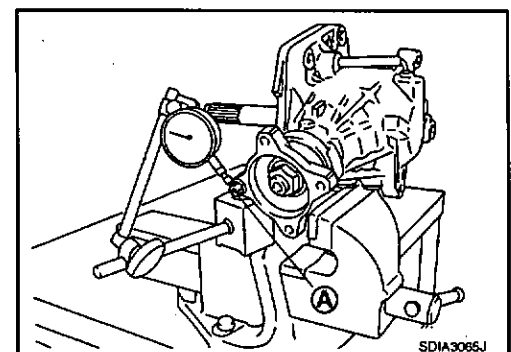

TOOTH CONTACT

1. Remove adapter case. Refer to DLN-60. "CVT : Disassembly".

DRIVE PINION

[TRANSFER: TY30A]

< DISASSEMBLY AND ASSEMBLY >

2. Remove ring gear shaft assembly from transfer case. Then apply red lead onto the ring gear.

CAUTION:

Apply red lead to both faces of 3 to 4 gears at 4 locations evenly spaced on the ring gear.

3. Assemble the ring gear shaft assembly to the transfer case.

4. Install adapter case. Refer to DLN-60, "CVT : Assembly".

5. Remove plug on the lower side of the transfer case.

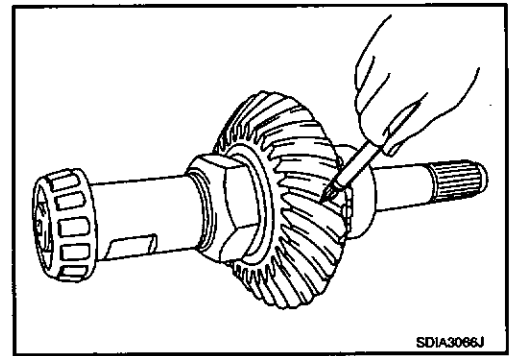

6. Rotate the companion flange back and forth several times. Then check drive pinion to ring gear tooth contact by viewing from the tooth contact test hole. (A: Drive side, B: Reverse side)

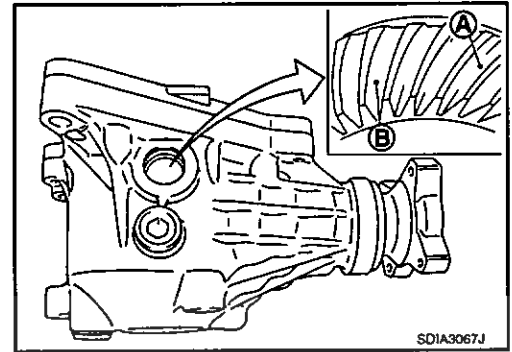

Tooth Contact Judgment Guide

Drive pinion adjusting shim selection value mm (in)	Tooth contact condition		Need for adjustment
	Drive side	Back	
Thicker ↑	+0.12 (+0.0047)	Heel side Toe side	Yes
	+0.09 (+0.0035)		
	+0.06 (+0.0024)		
	+0.03 (+0.0012)		
	0 (0.0)		
Thinner ↓	-0.03 (-0.0012)		Yes
	-0.06 (-0.0024)		
	-0.09 (-0.0035)		
-0.12 (-0.0047)			

JSDIA0219GB

A
B
C
DLN
E
F
G
H
I
J
K
L
M
N
O
P

DRIVE PINION

< DISASSEMBLY AND ASSEMBLY >

[TRANSFER: TY30A]

- Follow the procedure below to adjust pinion height (dimension X) if tooth contact is improper.

CAUTION:

If no adjusting shim with the calculated value is available, select the thicker and closest one.

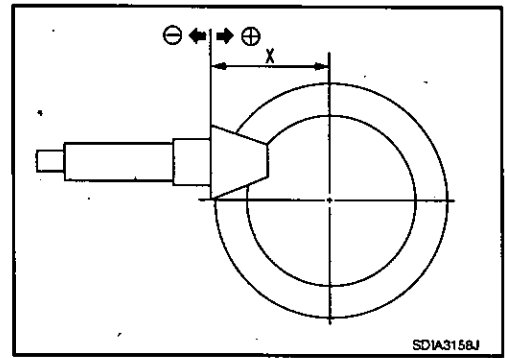

- Thicken the drive pinion adjusting shim to move the drive pinion closer to the ring gear in case of face contact or heel contact.

CAUTION:

Only one adjusting shim can be selected.

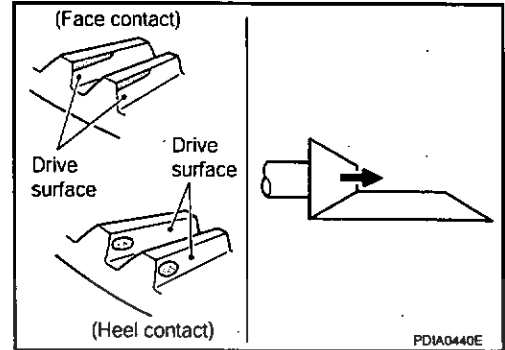

- Thin the drive pinion adjusting shim to move the drive pinion farther from the ring gear in case of flank contact or toe contact.

CAUTION:

Only one adjusting shim can be selected.

- Assemble the plug to the transfer case.

CAUTION:

- Remove old gasket on mounting surface, then remove any moisture, oil, and foreign material on the application and mounting surfaces.
- Apply liquid gasket to the thread, and tighten to the specified torque when installing plug.

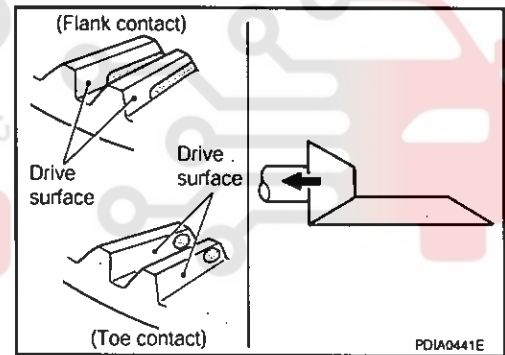

DRIVE PINION BEARING PRELOAD

- Remove adapter case. Refer to DLN-60. "CVT : Disassembly".
- Remove ring gear shaft assembly from the transfer case.
- Rotate the companion flange back and forth from 2 to 3 times to check for unusual noise, binding, sticking, and so on.
- Rotate the companion flange at least 20 times to check for smooth operation of the bearing.
- Measure the drive pinion bearing preload with a preload gauge (A) (SST: ST3127S000).

Standard

Drive pinion bearing preload : Refer to DLN-102. "Preload Torque".

CAUTION:

Each rotational part should rotate smoothly with the specified gear oil.

- Disassemble the drive pinion assembly to check and adjust each part if outside the standard.

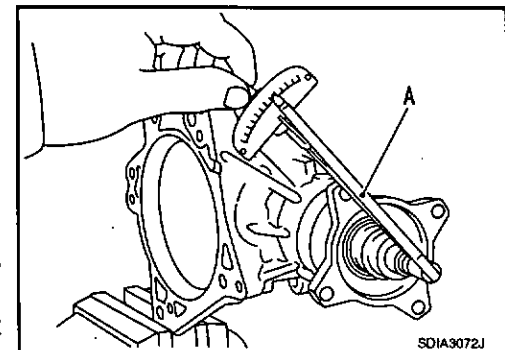

TOTAL PRELOAD

- Measure drive pinion bearing preload (P1). Refer to "DRIVE PINION BEARING PRELOAD".

DRIVE PINION

< DISASSEMBLY AND ASSEMBLY >

[TRANSFER: TY30A]

CAUTION:

Check that the drive pinion bearing preload is within the standard.

2. Assemble the ring gear shaft assembly to the transfer case.
3. Install adapter case. Refer to DLN-60 "CVT : Assembly".
4. Rotate the companion flange at least 20 times to check for smooth operation of the bearing.
5. Measure the total preload with a preload gauge (A) (SST: ST3127S000).

Standard

Total preload

All oil seals are installed : Refer to DLN-102 "Preload Torque".

Without adapter case oil seal : Refer to DLN-102 "Preload Torque".

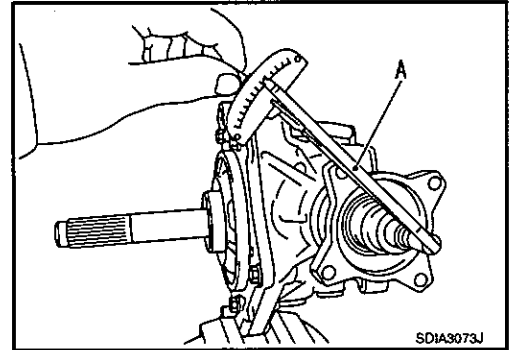

CAUTION:

- Each rotational part should rotate smoothly with the specified gear oil.
- Disassemble the transfer assembly to check and adjust each part if outside the standard. Measure it with the adapter case oil seals removed when measuring total preload after disassembly. Then install adapter case oil seals.

COMPANION FLANGE RUNOUT

1. Fit a dial indicator onto the companion flange face (inner side of the propeller shaft bolt holes).
2. Rotate the companion flange to check for runout.

Limit
Companion flange runout : Refer to DLN-102 "Companion Flange Runout".

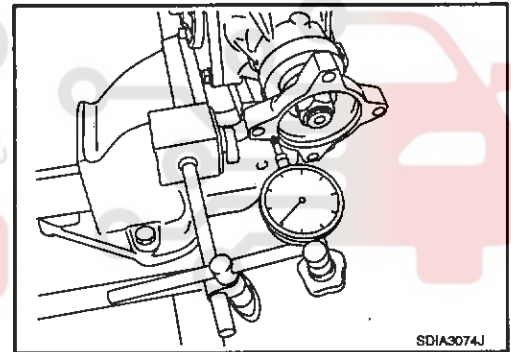

3. Fit a test indicator to the inner side of the companion flange (socket diameter).
4. Rotate the companion flange to check for runout.

Limit
Companion flange runout : Refer to DLN-102 "Companion Flange Runout".

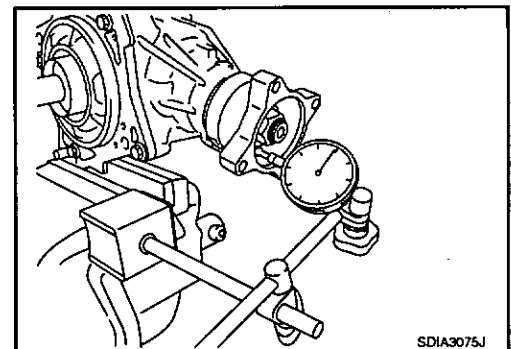

5. Follow the procedure below to adjust if runout value is outside the repair limit.

CAUTION:

Replace collapsible spacer to check and adjust each part when companion flange is adjusted or replaced.

- a. Check for runout while changing the phase between companion flange and drive pinion in 90° steps. Then search for the minimum point.
- b. Replace companion flange if runout value is still outside the limit after the phase has been changed.
- c. Adjust assembly status of the drive pinion bearings and drive pinion, or replace drive pinion bearings if runout is outside the standard after the companion flange is replaced.

ADJUSTING SHIM SELECTION

Measuring Point

A
B
C
DLN
E
F
G
H
I
J
K
L
M
N
O
P

DRIVE PINION

< DISASSEMBLY AND ASSEMBLY >

[TRANSFER: TY30A]

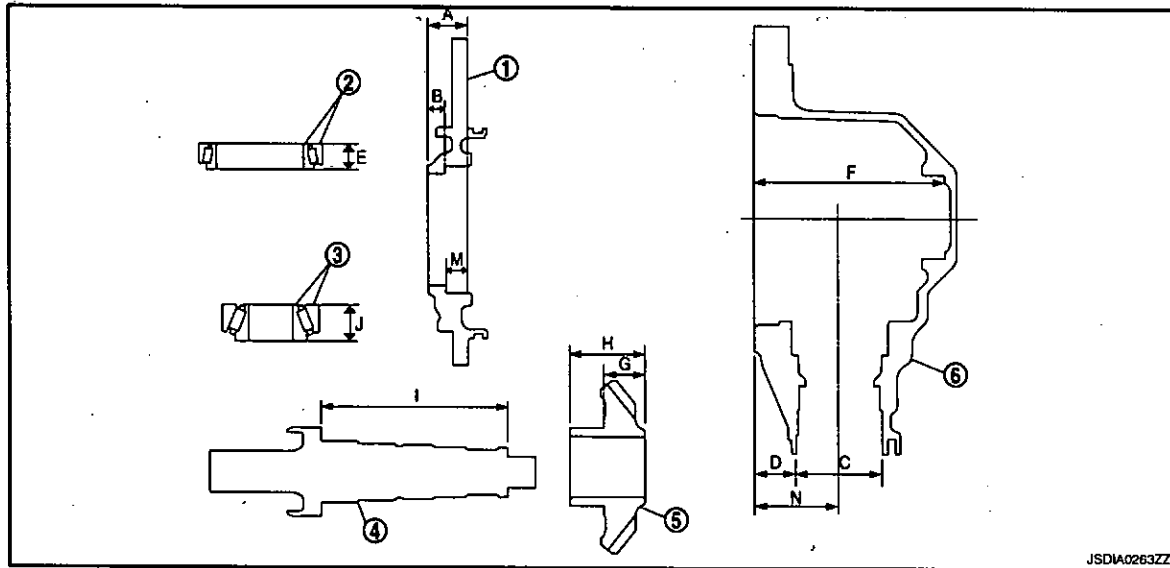

- | | | |
|--------------------|--|---|
| 1. Adapter case | 2. Ring gear shaft bearing (Adapter case side) | 3. Ring gear shaft bearing (Transfer case side) |
| 4. Ring gear shaft | 5. Ring gear | 6. Transfer case |

Ring Gear Adjusting Shim (Adapter Case Side)

1. Measure the dimensions of each measuring point with the following procedure:

Dimension "A" measurement

- Measure dimension from transfer case mounting surface of adapter case to adapter case edge surface with a pair of vernier calipers and straightedge. Refer to "Measuring point".

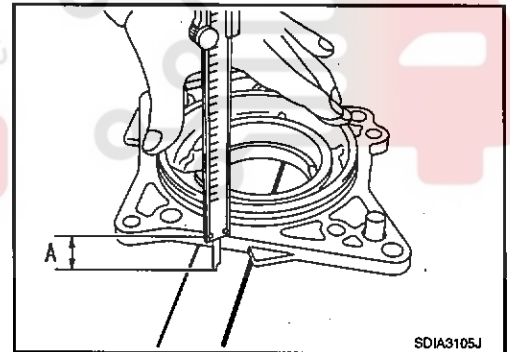

Dimension "B" measurement

- Measure dimension from ring gear adjusting shim mounting surface of adapter case to adapter case edge surface with a pair of vernier calipers and straightedge. Refer to "Measuring point".

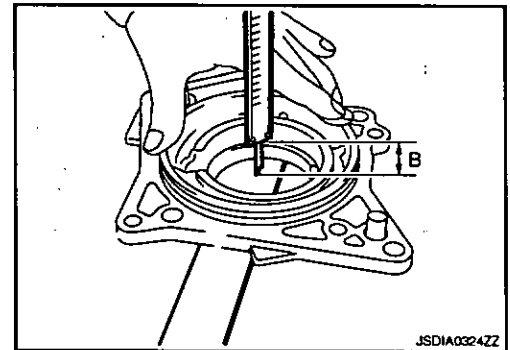

Dimension "C" measurement

DRIVE PINION

[TRANSFER: TY30A]

< DISASSEMBLY AND ASSEMBLY >

- Measure the diameter of drive pinion bearing (rear side) mounting area of transfer case with a pair of vernier calipers. Refer to "Measuring point".
CAUTION:
Never damage transfer case.

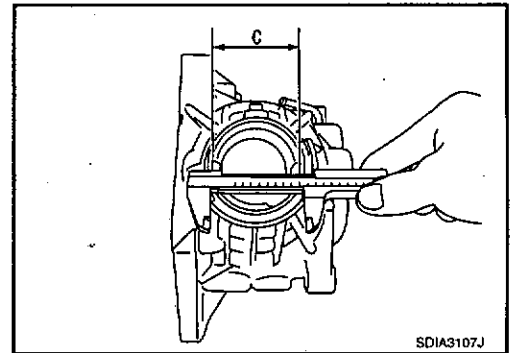

A
B
C

DLN

Dimension "D" measurement

- Measure dimension from adapter case mounting surface of transfer case to drive pinion bearing (rear side) mounting surface with a pair of vernier calipers and straightedge. Refer to "Measuring point".
CAUTION:
 - Never damage transfer case.
 - Consider the thickness of a straightedge.

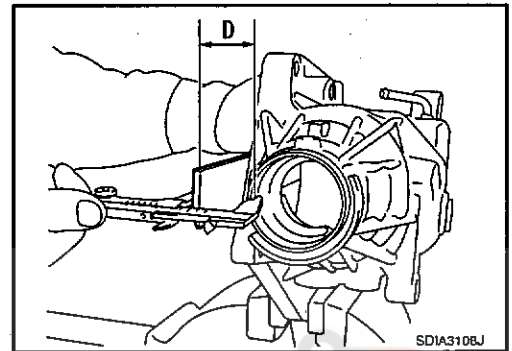

E
F
G

H

Dimension "E" measurement

- Measure dimension from outer race edge surface of ring gear shaft bearing (adapter case side) to inner race edge surface with a pair of vernier calipers. Refer to "Measuring point".

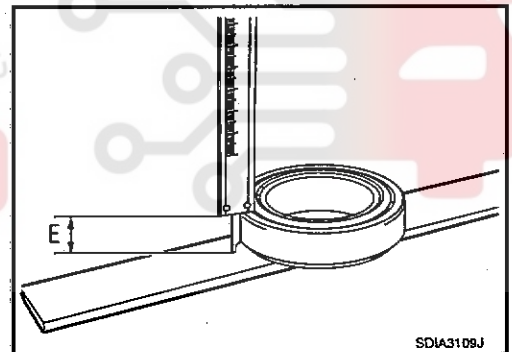

I
J
K

L

2. Calculate dimensions "M" and "N" by the formula below.

Dimension "M" = "A" - "B"

Dimension "N" = "C" × 0.5 mm (0.020 in) + "D"

M

3. Convert the dimensions "E", "M" and "N" according to the standards below.

N

"E" : Actual value regarding 20.00 mm (0.7874 in) as 0 in increments of 0.01 mm (0.0004 in).

"M" : Actual value regarding 13.90 mm (0.5472 in) as 0 in increments of 0.01 mm (0.0004 in).

O

"N" : Actual value regarding 55.00 mm (2.1654 in) as 0 in increments of 0.01 mm (0.0004 in).

P

DRIVE PINION

< DISASSEMBLY AND ASSEMBLY >

[TRANSFER: TY30AJ]

4. Check dimension "Z" (machining difference) on the ring gear back surface.

NOTE:

Dimension "Z" indicates difference between optimum engagement and the standard dimensions in increments of 0.01 mm (0.0004 in) written on the ring gear back surface.

5. Calculate the thickness of the ring gear adjusting shim (adapter case side) "T1" by the formula below.

$$"T_1" = ("M" + "N" - "E" - "Z") \times 0.01 \text{ mm (0.0004 in)} + 1.40 \text{ mm (0.0551 in)}$$

6. Select ring gear adjusting shim (adapter case side).

CAUTION:

- Only one adjusting shim can be selected.
- Select the closest one, favoring thicker over thinner when necessary if no adjusting shim with the calculated value is available.

Ring Gear Adjusting Shim (Transfer Case Side)

1. Measure the dimensions of each measuring point with the following procedure:

Dimension "C" measurement

- Measure the diameter of drive pinion bearing (rear side) mounting area of transfer case with a pair of vernier calipers. Refer to "Measuring point".

CAUTION:

- Never damage transfer case.

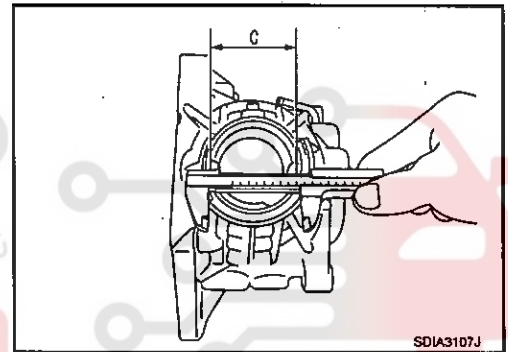

دیجیتال خودرو شرکت دیجیتال خودرو سامانه (مسئولیت محدود)

اولین سامانه دیجیتال تعمیرکاران خودرو در ایران

Dimension "D" measurement

- Measure dimension from adapter case mounting surface of transfer case to drive pinion bearing (rear side) mounting surface with a pair of vernier calipers and straightedge. Refer to "Measuring point".

CAUTION:

- Never damage transfer case.
- Consider the thickness of a straightedge.

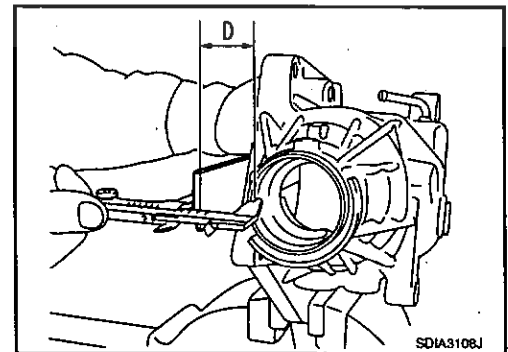

Dimension "F" measurement

- Measure dimension from adapter case mounting surface of transfer case to ring gear adjusting shim mounting surface with a depth gauge. Refer to "Measuring point".

CAUTION:

- Never damage transfer case.

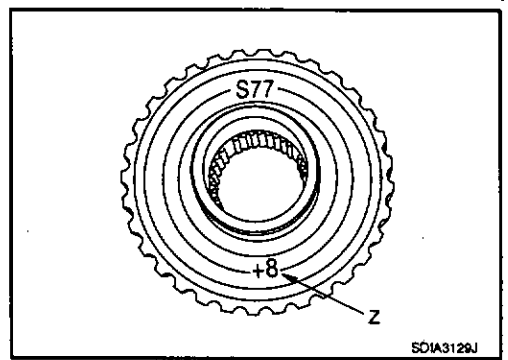
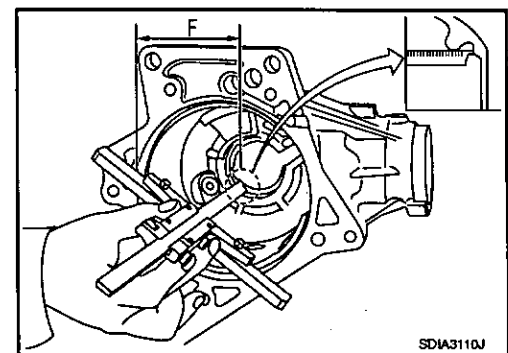

DRIVE PINION

< DISASSEMBLY AND ASSEMBLY >

[TRANSFER: TY30A]

Dimension "G" measurement

- Measure dimension from ring gear shaft bearing mounting surface of ring gear to transfer case side edge surface with a micrometer and straightedge. Refer to "Measuring point".

CAUTION:

Consider the thickness of a straightedge.

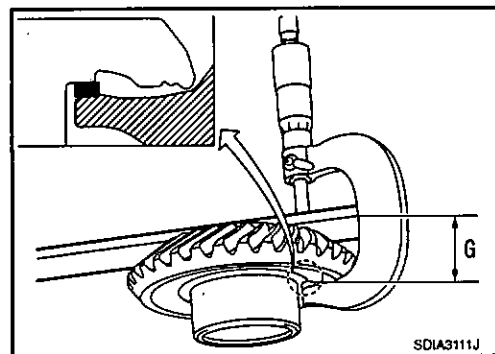

A
B
C

DLN

Dimension "H" measurement

- Measure dimension from transfer case side edge surface of ring gear to adapter case side edge surface with a pair of vernier calipers. Refer to "Measuring point".

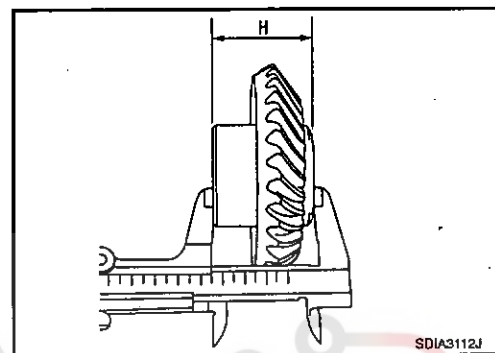

E
F
G
H

Dimension "I" measurement

- Measure dimension from ring gear mounting surface of ring gear shaft to ring gear shaft bearing (transfer case side) mounting surface with a pair of vernier calipers. Refer to "Measuring point".

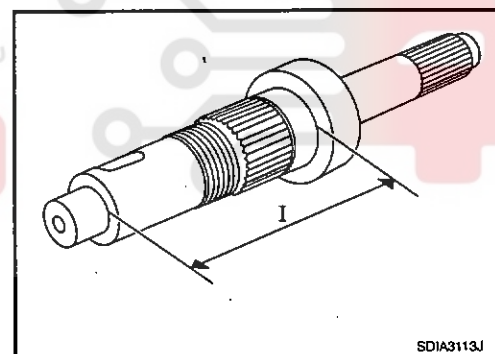

I
J
K
L

Dimension "J" measurement

- Measure dimension from outer race edge surface of ring gear shaft bearing (transfer case side) to inner race edge surface with a pair of vernier calipers. Refer to "Measuring point".

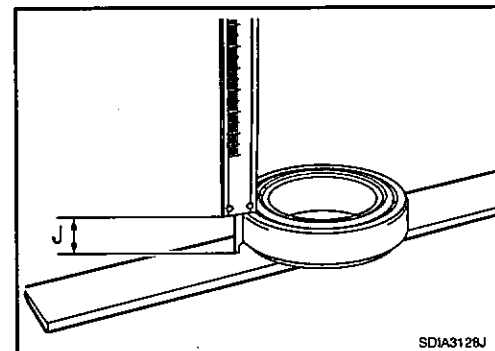

M
N
O
P

2. Calculate dimension "N" by the formula below.

$$\text{Dimension "N"} = \text{"C"} \times 0.5 \text{ mm (0.020 in)} + \text{"D"}$$

3. Convert the dimensions "F", "G", "H", "I", "J" and "N" according to the standards below.

DRIVE PINION

< DISASSEMBLY AND ASSEMBLY >

[TRANSFER: TY30A]

- "F" : Actual value regarding 122.60 mm (4.83 in) as 0 in increments of 0.01 mm (0.0004 in).
- "G" : Actual value regarding 26.60 mm (1.0472 in) as 0 in increments of 0.01 mm (0.0004 in).
- "H" : Actual value regarding 48.60 mm (1.9134 in) as 0 in increments of 0.01 mm (0.0004 in).
- "I" : Actual value regarding 119.40 mm (4.70 in) as 0 in increments of 0.01 mm (0.0004 in).
- "J" : Actual value regarding 16.25 mm (0.6398 in) as 0 in increments of 0.01 mm (0.0004 in).
- "N" : Actual value regarding 55.00 mm (2.1654 in) as 0 in increments of 0.01 mm (0.0004 in).

4. Check dimension "Z" (machining difference) on the ring gear back surface.

NOTE:

Dimension "Z" indicates difference between optimum engagement and the standard dimensions in increments of 0.01 mm (0.0004 in) written on the ring gear back surface.

5. Calculate the thickness of the ring gear adjusting shim (transfer case side) "T2" by the formula below.

$$"T_2" = ("F" - "G" + "H" - "I" - "J" - "N" + "Z") \times 0.01 \text{ mm (0.0004 in)} + 1.65 \text{ mm (0.0650 in)}$$

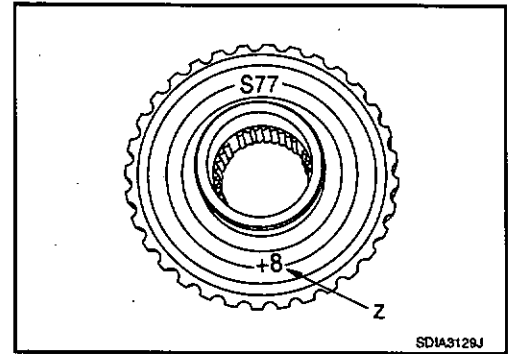

6. Select ring gear adjusting shim (transfer case side).

CAUTION:

- Only one adjusting shim can be selected.
- Select the closest one, favoring thicker over thinner when necessary if no adjusting shim with the calculated value is available.

Drive Pinion Adjusting Shim

1. Check the dimension "U" (machining difference) between old and new drive pinions when hypoid gear set (drive pinion and ring gear) has been replaced.

(Assemble new drive pinion adjusting shims with the same thickness as the ones removed prior to disassembly or removed drive pinion adjusting shims when reusing the hypoid gear set.)

NOTE:

Dimension "U" indicates the difference between optimum engagement and the standard dimensions in increments of 0.01 mm (0.0004 in). It is written on the gear end of the drive pinion for reference.

2. Calculate the thickness of the drive pinion adjusting shim "T" by the formula below.

$$"T" = T_0 + [(t_1 - t_2) \times 0.01 \text{ mm (0.0004 in)}]$$

- "T" : Thickness of new shim
- T₀ : Thickness of old shim
- t₁ : Dimension "U" displayed on the gear end of old drive pinion
- t₂ : Dimension "U" displayed on the gear end of new drive pinion

[Example]

$$"T" = 3.21 + [(2 + 1) \times 0.01 \text{ mm (0.0004 in)}]$$

- T₀ : 3.21
- t₁ : +2
- t₂ : -1

3. Select drive pinion adjusting shim.

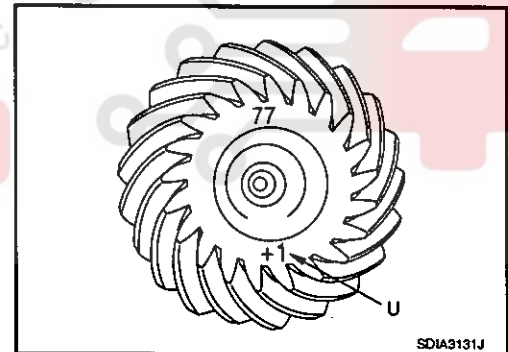

DRIVE PINION

< DISASSEMBLY AND ASSEMBLY >

[TRANSFER: TY30A]

CAUTION:

- Only one adjusting shim can be selected.
- Select the closest one, if no adjusting shim with the calculated value is available.

CVT : Inspection After Disassembly

INFOID:000000004905467

Check items below. If necessary, replace them with new ones.

GEAR AND SHAFT

Check gear face and shaft for wear, cracks, damage, and seizure.

CAUTION:

Replace ring gear and drive pinion as a set (hypoid gear set) if any malfunction is detected on the ring gear or drive pinion.

BEARING

Check for seizure, peeling, wear, corrosion, sticking, unusual noise, roughness in hand turning, and other damage.

CAUTION:

Always replace inner race and outer race as a pair when replacing the bearing.

SHIM

Check for seizure, damage, and unusual wear.

CASE

Check the bearing mounting surface for wear, cracks and damages.

دیجیتال خودرو

شرکت دیجیتال خودرو سامانه (مسئولیت محدود)

اولین سامانه دیجیتال تعمیرکاران خودرو در ایران

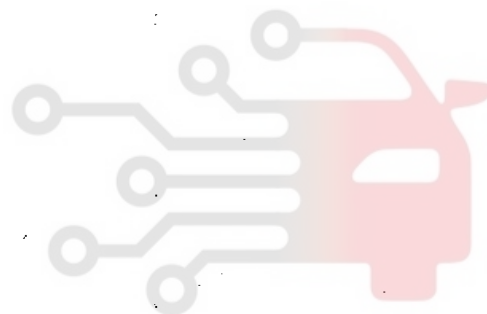

A
B
C
DLN
E
F
G
H
I
J
K
L
M
N
O
P

TRANSFER CASE

< DISASSEMBLY AND ASSEMBLY >

[TRANSFER: TY30A]

TRANSFER CASE

M/T

M/T : Exploded View

INFOID:000000004905468

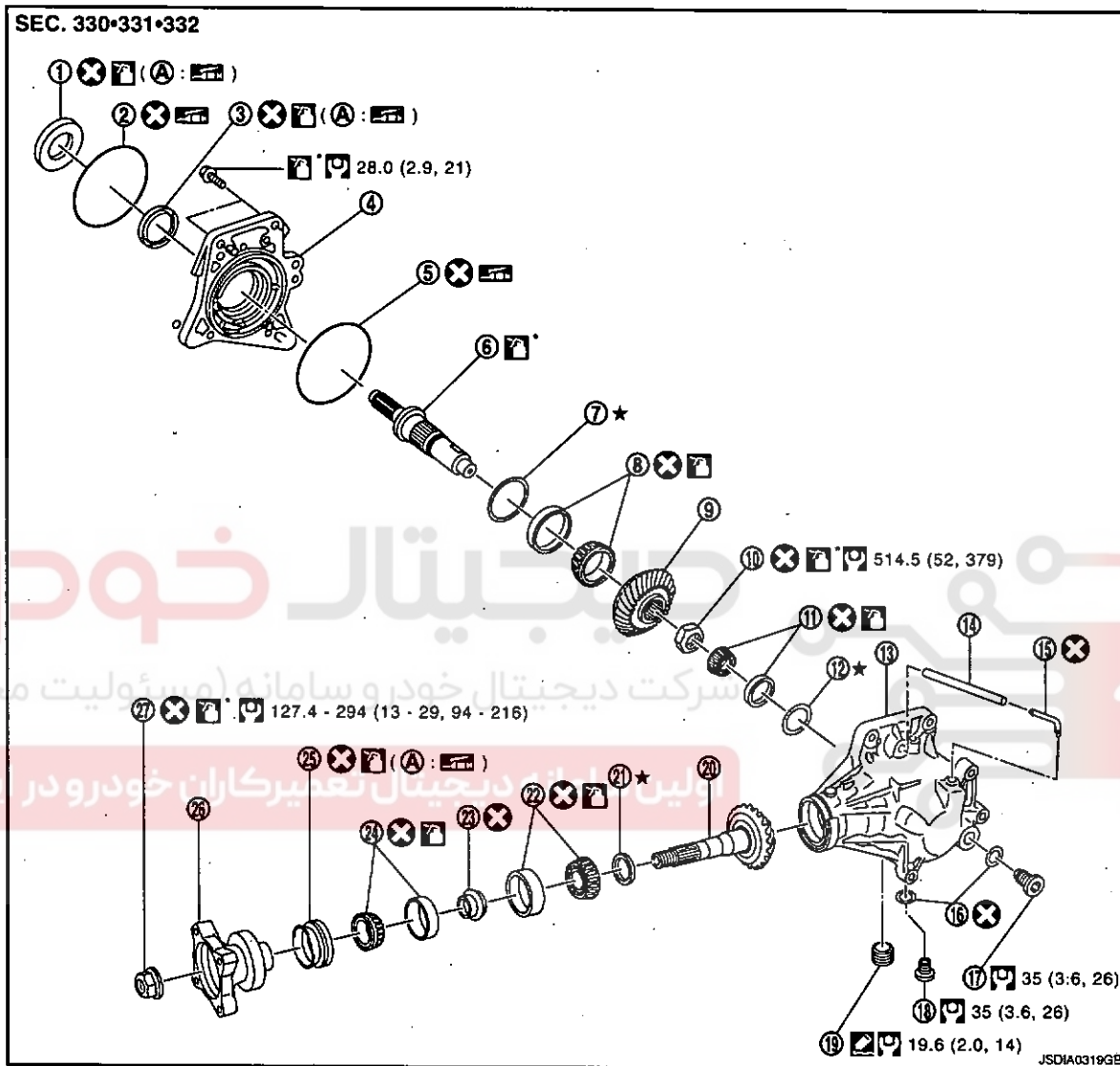

- | | | |
|---|--|---|
| 1. Adapter case oil seal (outer) | 2. O-ring (outer) | 3. Adapter case oil seal (inner) |
| 4. Adapter case | 5. O-ring (inner) | 6. Ring gear shaft |
| 7. Ring gear adjusting shim (adapter case side) | 8. Ring gear shaft bearing (adapter case side) | 9. Ring gear |
| 10. Ring gear nut | 11. Ring gear shaft bearing (transfer case side) | 12. Ring gear adjusting shim (transfer case side) |
| 13. Transfer case | 14. Air breather hose | 15. Air breather tube |
| 16. Gasket | 17. Filler plug | 18. Drain plug |
| 19. Plug | 20. Drive pinion | 21. Drive pinion adjusting shim |
| 22. Drive pinion bearing (front side) | 23. Collapsible spacer | 24. Drive pinion bearing (rear side) |
| 25. Drive pinion oil seal | 26. Companion flange | 27. Lock nut |

A: Oil seal lip

Apply gear oil.

Apply multi-purpose grease.

TRANSFER CASE

< DISASSEMBLY AND ASSEMBLY >

[TRANSFER: TY30A]

: Apply anti-corrosive oil.

: Apply Genuine Liquid Gasket, Three Bond 1215 or an equivalent.
Refer to GI-3, "Components" for symbols not described on the above.

M/T : Disassembly

INFOID:000000004905469

1. Remove adapter case. Refer to DLN-57, "M/T : Disassembly".
2. Remove ring gear shaft assembly. Refer to DLN-63, "M/T : Disassembly".
3. Remove drive pinion assembly. Refer to DLN-71, "M/T : Disassembly".
4. Tap the outer race of drive pinion bearing from transfer case with a brass rod to remove outer race of drive pinion bearing (front side and rear side).
CAUTION:
Never damage transfer case.
5. Remove air breather hose from transfer case.
CAUTION:
Never damage air breather hose.
6. Remove air breather tube from transfer case.
7. Remove the filler plug and drain plug from the transfer case, and then remove each gasket.
8. Remove plug from transfer case.

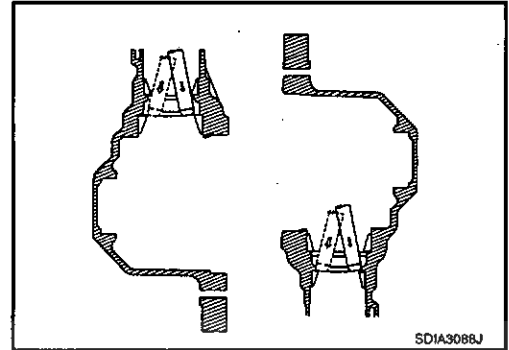

M/T : Assembly

INFOID:000000004905470

1. Install outer race of drive pinion bearing (front side) to the transfer case with drifts and bushing remover.
A : Drift (commercial service tool)
B : Drift (SST: ST35272000)
C : Bushing remover (SST: ST38280000)

CAUTION:
• Never reuse drive pinion bearing (front side).
• Apply gear oil to the drive pinion bearing (front side)

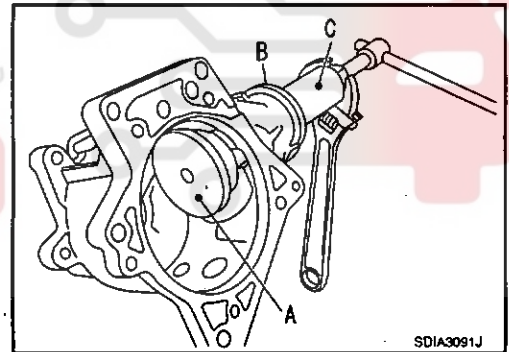

2. Install outer race of drive pinion bearing (rear side) to transfer case with a drift (A) (SST: ST33230000).
CAUTION:
• Never reuse drive pinion bearing (rear side).
• Apply gear oil to the drive pinion bearing (rear side).
3. Install drive pinion assembly. Refer to DLN-72, "M/T : Assembly".
4. Install ring gear shaft assembly. Refer to DLN-64, "M/T : Assembly".
5. Install adapter case. Refer to DLN-57, "M/T : Assembly".

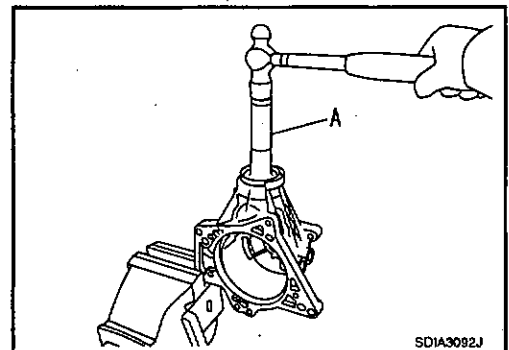

TRANSFER CASE

< DISASSEMBLY AND ASSEMBLY >

[TRANSFER: TY30A]

6. Install the air breather tube to the transfer case with its opening facing (A) rearward from transfer input shaft direction (B).

Angle "A" : 25° - 45°

CAUTION:

Never reuse air breather tube.

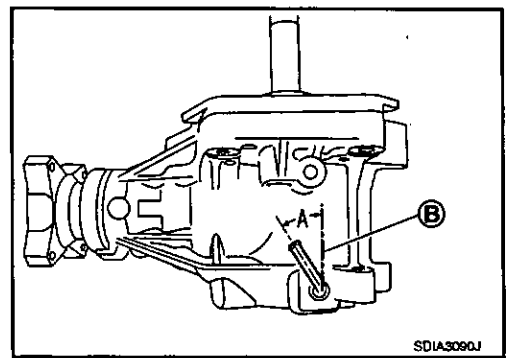

7. Install air breather hose.

CAUTION:

- Never damage air breather hose.
- Face the paint area (A) in the direction shown in the figure.

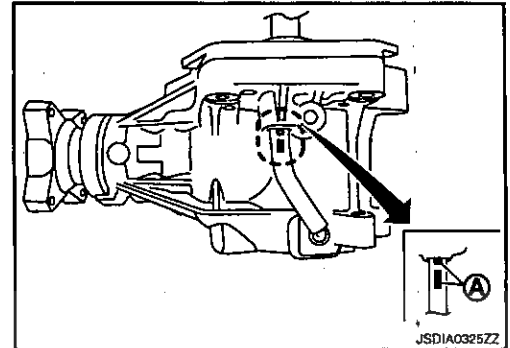

8. Check backlash, tooth contact, total preload and companion flange runout. Refer to DLN-73, "M/T : Adjustment".

CAUTION:

Measure the total preload without the adapter case oil seals.

9. Assemble the plug to the transfer case.

CAUTION:

- Remove old gasket on mounting surface, then remove any moisture, oil, and foreign material on the application and mounting surfaces.
- Apply liquid gasket to the threads of plug.

10. Install gaskets onto filler plug and drain plug and install them into transfer case.

CAUTION:

- Never reuse gaskets.
- Install filler plug after oil is filled.

M/T : Inspection

INFOID:000000004905471

Check items below. If necessary, replace them with new ones.

CASE

Check the bearing mounting surface for wear, cracks and damages.

CVT

TRANSFER CASE

< DISASSEMBLY AND ASSEMBLY >

[TRANSFER: TY30A]

CVT : Exploded View

INFOID.000000004905472

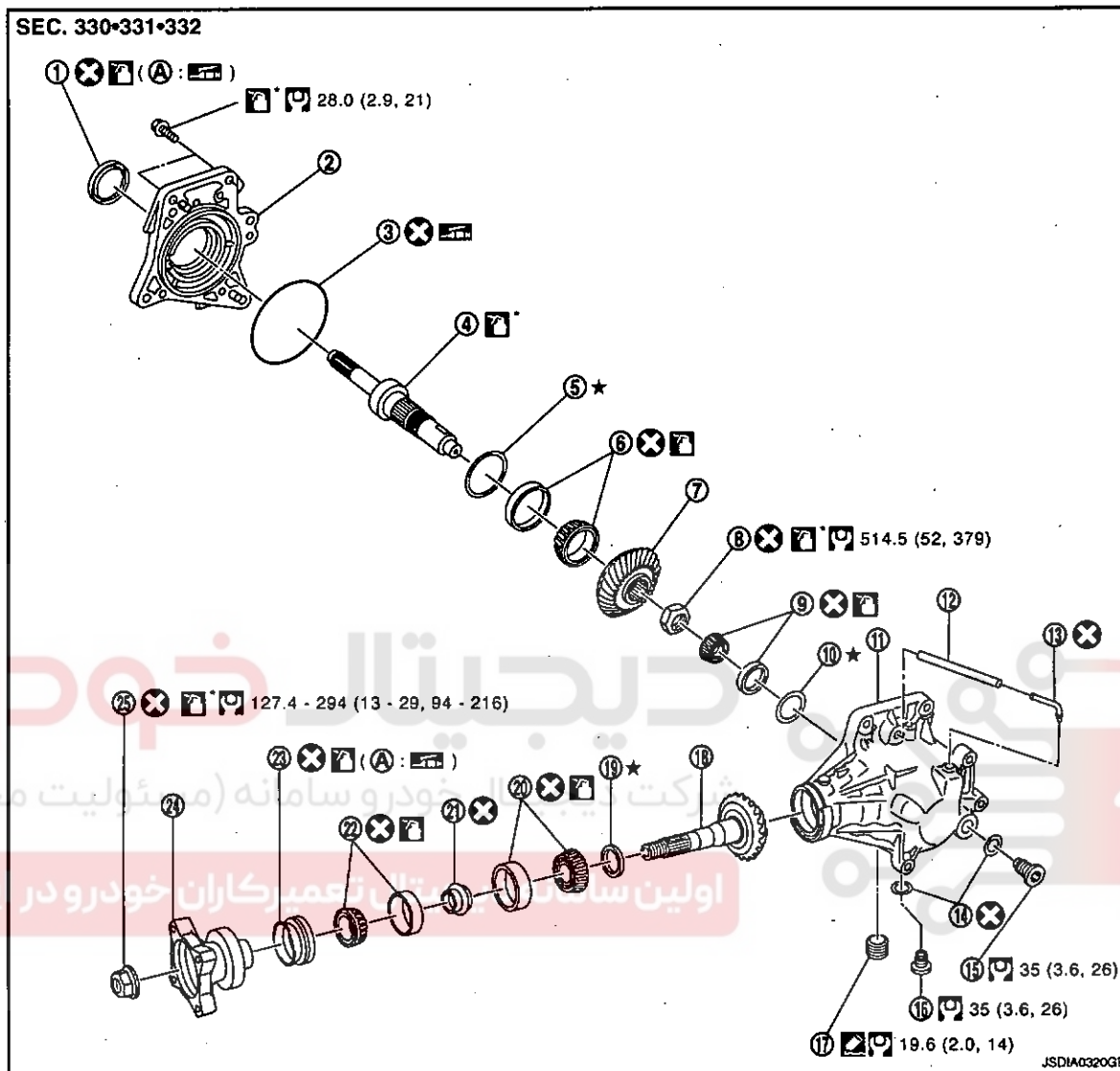

- | | | |
|---|---|---|
| 1. Adapter case oil seal | 2. Adapter case | 3. O-ring |
| 4. Ring gear shaft | 5. Ring gear adjusting shim (adapter case side) | 6. Ring gear shaft bearing (adapter case side) |
| 7. Ring gear | 8. Ring gear nut | 9. Ring gear shaft bearing (transfer case side) |
| 10. Ring gear adjusting shim (transfer case side) | 11. Transfer case | 12. Air breather hose |
| 13. Air breather tube | 14. Gasket | 15. Filler plug |
| 16. Drain plug | 17. Plug | 18. Drive pinion |
| 19. Drive pinion adjusting shim | 20. Drive pinion bearing (front side) | 21. Collapsible spacer |
| 22. Drive pinion bearing (rear side) | 23. Drive pinion oil seal | 24. Companion flange |
| 25. Lock nut | | |
- A: Oil seal lip

- : Apply gear oil.
- : Apply multi-purpose grease.
- : Apply anti-corrosive oil.

A
B
C
DLN
E
F
G
H
I
J
K
L
M
N
O
P

TRANSFER CASE

< DISASSEMBLY AND ASSEMBLY >

[TRANSFER: TY30A]

-  Apply Genuine Liquid Gasket, Three Bond 1215 or an equivalent.
Refer to GI-3, "Components" for symbols not described on the above.

CVT : Disassembly

INFOID:000000004905473

1. Remove adapter case. Refer to DLN-60, "CVT : Disassembly".
2. Remove ring gear shaft assembly. Refer to DLN-67, "CVT : Disassembly".
3. Remove drive pinion assembly. Refer to DLN-84, "CVT : Disassembly".
4. Tap the outer race of drive pinion bearing from transfer case with a brass rod to remove outer race of drive pinion bearing (front side and rear side).
CAUTION:
Never damage transfer case.
5. Remove air breather hose from transfer case.
CAUTION:
Never damage air breather hose.
6. Remove air breather tube from transfer case.
7. Remove the filler plug and drain plug from the transfer case, and then remove each gasket.
8. Remove plug from transfer case.

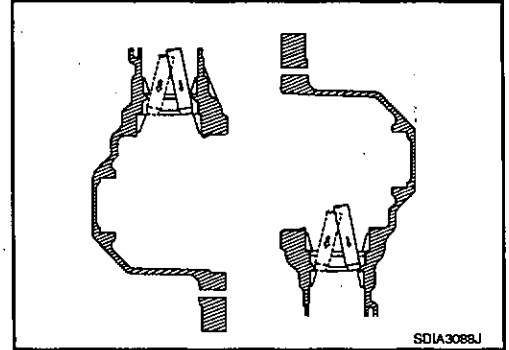

CVT : Assembly

INFOID:000000004905474

1. Install outer race of drive pinion bearing (front side) to the transfer case with drifts and bushing remover.

- A : Drift (SST: ST30621000)
B : Drift (SST: ST35272000)
C : Bushing remover (SST: ST38280000)

- CAUTION:**
- Never reuse drive pinion bearing (front side).
 - Apply gear oil to the drive pinion bearing (front side)

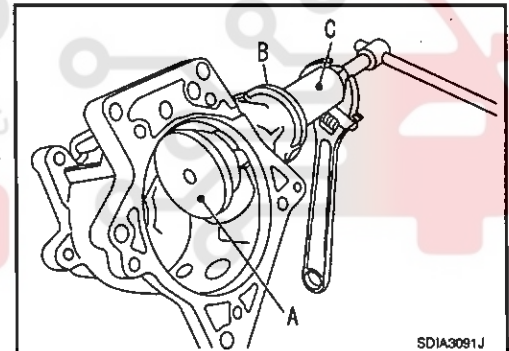

2. Install outer race of drive pinion bearing (rear side) to transfer case with a drift (A) (SST: ST33230000).

- CAUTION:**
- Never reuse drive pinion bearing (rear side).
 - Apply gear oil to the drive pinion bearing (rear side).

3. Install drive pinion assembly. Refer to DLN-85, "CVT : Assembly".
4. Install ring gear shaft assembly. Refer to DLN-68, "CVT : Assembly".
5. Install adapter case. Refer to DLN-60, "CVT : Assembly".

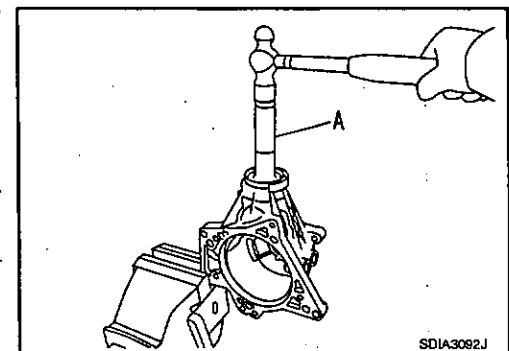

TRANSFER CASE

< DISASSEMBLY AND ASSEMBLY >

[TRANSFER: TY30A]

6. Install the air breather tube to the transfer case with its opening facing (A) rearward from transfer input shaft direction (B).

Angle "A" : 25° – 45 °

CAUTION:

Never reuse air breather tube.

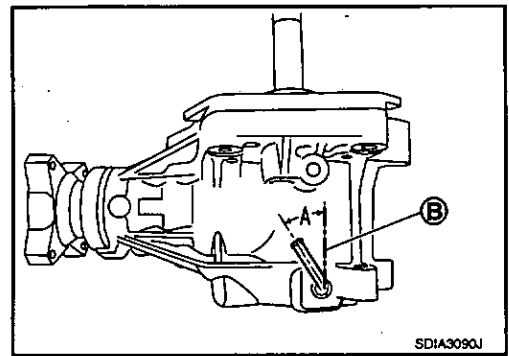

7. Install air breather hose.

CAUTION:

- Never damage air breather hose.
- Face the paint area (A) in the direction shown in the figure.

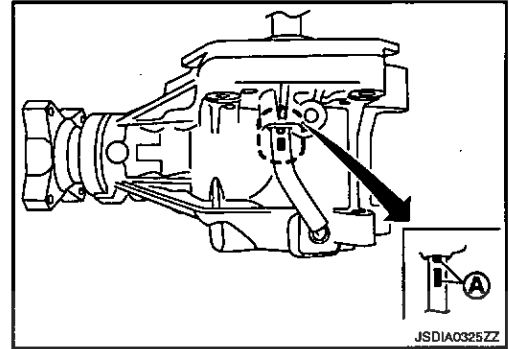

8. Check backlash, tooth contact, total preload and companion flange runout. Refer to [DLN-86](#), "CVT : Adjustment".

CAUTION:

Measure the total preload without the adapter case oil seals.

9. Assemble the plug to the transfer case.

CAUTION:

- Remove old gasket on mounting surface, then remove any moisture, oil, and foreign material on the application and mounting surfaces.
- Apply liquid gasket to the threads of plug.

10. Install gaskets onto filler plug and drain plug and install them into transfer case.

CAUTION:

- Never reuse gaskets.
- Install filler plug after oil is filled.

CVT : Inspection

INFOID.000000004905475

Check items below. If necessary, replace them with new ones.

CASE

Check the bearing mounting surface for wear, cracks and damages.

SERVICE DATA AND SPECIFICATIONS (SDS)

< SERVICE DATA AND SPECIFICATIONS (SDS)

[TRANSFER: TY30A]

SERVICE DATA AND SPECIFICATIONS (SDS)

SERVICE DATA AND SPECIFICATIONS (SDS)

General Specifications

INFOID:000000004905476

Applied model		4WD		
		MR20DE		M9R
		M/T	CVT	M/T
Transfer model		TY30A		
Oil capacity (Approx.)	ℓ (Imp pt)	0.38 (5/8)	0.36 (5/8)	0.38 (5/8)
Gear ratio		0.656		
Number of teeth	Drive pinion	32		
	Drive gear	21		

Preload Torque

INFOID:000000004905477

Unit: N·m (kg·m, in·lb)

Item	Standard	
	M/T	CVT
Drive pinion bearing preload (P1)	0.52 – 1.01 (0.06 – 0.10, 5 – 8)	
Total preload	With all oil seals	P1 + 0.76 – 0.96 (0.08 – 0.09, 7 – 8)
	Without adapter case oil seal	P1 + 0.55 – 0.75 (0.06 – 0.07, 5 – 6)

Backlash

INFOID:000000004905478

Unit: mm (in)

Item	Standard
Ring gear to drive pinion	0.13 – 0.19 (0.0051 – 0.0075)

Companion Flange Runout

INFOID:000000004905479

Unit: mm (in)

Item	Limit
Companion flange face (inner side of the propeller shaft bolt holes)	0.1 (0.004)
Inside of companion flange (socket diameter)	0.1 (0.004)

SYMPTOM DIAGNOSIS

NOISE, VIBRATION AND HARSHNESS (NVH) TROUBLESHOOTING

NVH Troubleshooting Chart

INFOID:000000004905480

Use the chart below to help you find the cause of the symptom. If necessary, repair or replace these parts.

Symptom	Noise	Shake	Vibration	Uneven rotating torque	Center bearing improper installation	Excessive center bearing axial end play	Center bearing mounting (insulator) cracks, damage or deterioration	Excessive joint angle	Rotation imbalance	Excessive runout	DIFFERENTIAL	AXLE AND SUSPENSION	TIRE	ROAD WHEEL	DRIVE SHAFT	BRAKE	STEERING
		x		x	x	x	x	x	x	x	x	x	x	x	x	x	x

x: Applicable

A
B
C
DLN
E
F
G
H
I
J
K
L
M
N
O
P

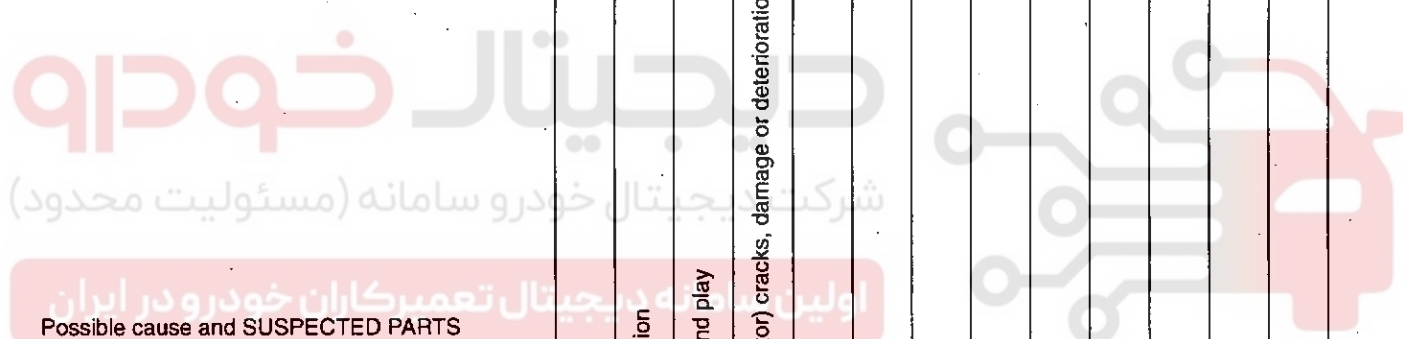

REAR PROPELLER SHAFT

< ON-VEHICLE MAINTENANCE >

[REAR PROPELLER SHAFT: 3F SPL18-DOJ75]

ON-VEHICLE MAINTENANCE

REAR PROPELLER SHAFT

Inspection

INFOID:000000004905481

NOISE

- Check the propeller shaft tube surface for dents or cracks. If damaged, replace propeller shaft assembly.
- If center bearing is noisy or damaged, replace propeller shaft assembly.

VIBRATION

If vibration is present at high speed, inspect propeller shaft runout first.

1. Measure propeller shaft runout at runout measuring points by rotating final drive companion flange with hands.

Limit

Propeller shaft runout : Refer to DLN-108. "Propeller Shaft Runout".

2. If runout still exceeds specifications, separate propeller shaft at final drive companion flange or transfer companion flange; then rotate companion flange 90 degrees and install propeller shaft. Check runout again. If the runout still exceeds the specifications, repeat the operation rotating the propeller shaft 90 more degrees until runout does not exceed the specifications or total rotation is 270 degrees.
3. If the runout still exceeds the specifications, replace the propeller shaft assembly.
4. Check the vibration by driving vehicle.

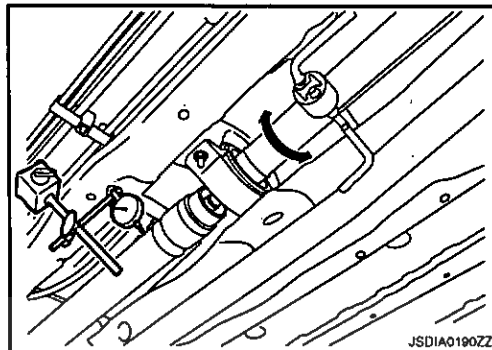

RUNOUT MEASURING POINT

Propeller shaft runout measuring point (Point "Δ").

- MR20DE

← : Vehicle front
اولین سامانه دیجیتال تعمیرکاران خودرو در ایران

Dimension

- A: 200 mm (7.87 in)
- B: 639 mm (25.16 in)
- C: 159 mm (6.26 in)

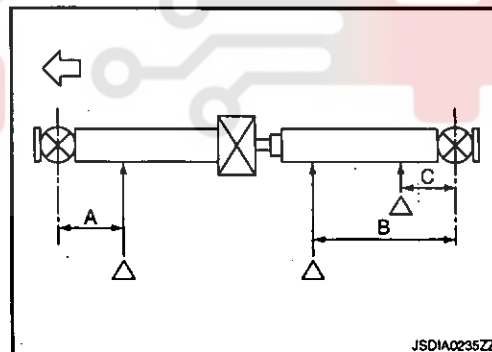

- M9R

← : Vehicle front

Dimension

- A: 495 mm (19.49 in)
- B: 416 mm (16.38 in)

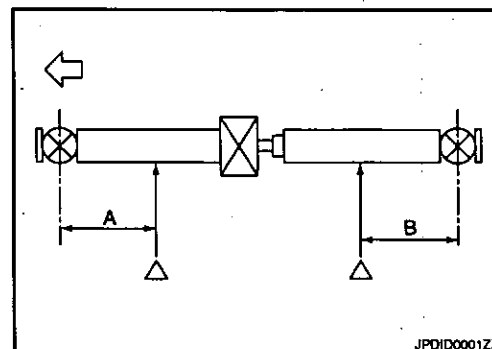

REAR PROPELLER SHAFT

[REAR PROPELLER SHAFT: 3F SPL18-DOJ75]

< ON-VEHICLE REPAIR >

ON-VEHICLE REPAIR

REAR PROPELLER SHAFT

Exploded View

INFOID:000000004905482

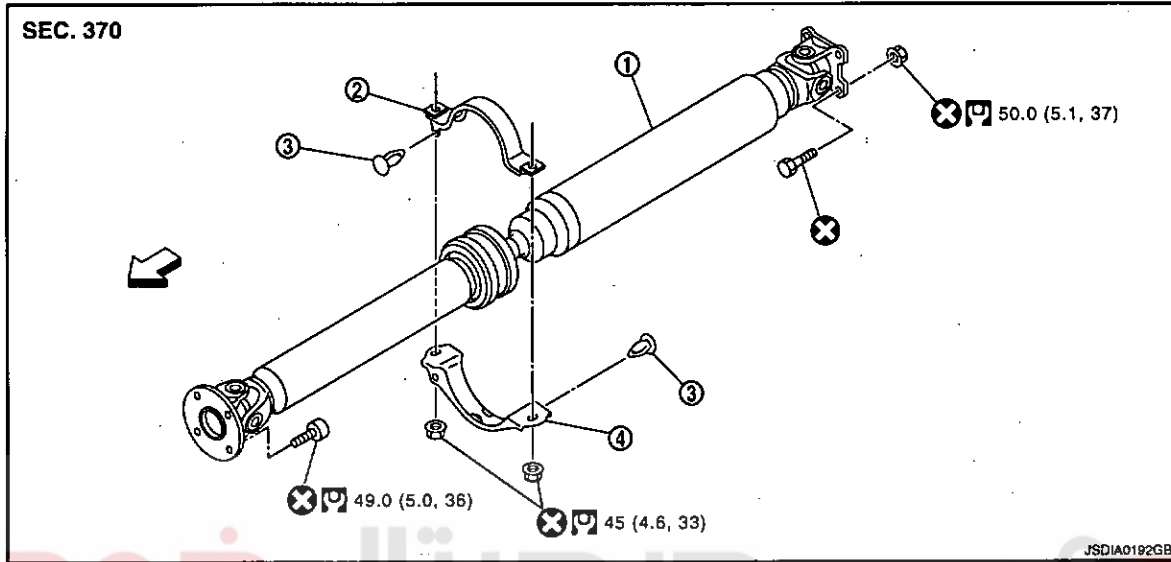

- 1. Propeller shaft assembly
- 2. Center bearing mounting bracket (upper)
- 3. Clip
- 4. Center bearing mounting bracket (lower)

↔: Vehicle front

Refer to GI-3, "Components" for symbols in the figure.

Removal and Installation

INFOID:000000004905483

REMOVAL

1. Shift the transaxle to the neutral position, and then release the parking brake.
2. Remove the main muffler and the exhaust front tube. Refer to EX-10, "Exploded View" (MR20DE), EX-15, "Exploded View" (M9R).
3. Put matching marks onto propeller shaft flange yoke and final drive and transfer companion flanges.

CAUTION:

For matching marks, use paint. Never damage propeller shaft flange yoke and transfer companion flange.

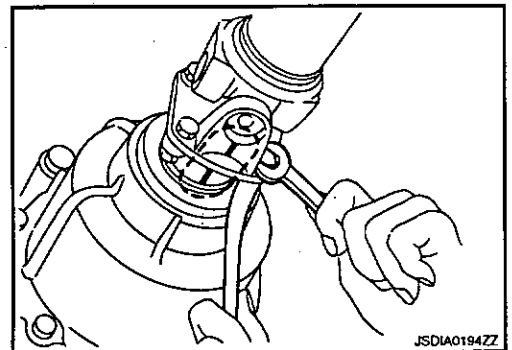

REAR PROPELLER SHAFT

< ON-VEHICLE REPAIR >

[REAR PROPELLER SHAFT: 3F SPL18-DOJ75]

- Loosen mounting nuts of center bearing mounting brackets.

↔ : Vehicle front

CAUTION:

Tighten mounting nuts temporarily.

- Remove propeller shaft assembly fixing bolts and nuts.
- Remove center bearing mounting bracket fixing nuts.
- Remove propeller shaft assembly.

CAUTION:

If constant velocity joint was bent during propeller shaft assembly removal, installation, or transportation, its boot may be damaged. Wrap boot interference area to metal part with shop cloth or rubber to protect boot from breakage.

- Remove clips and center bearing mounting bracket (upper/lower).

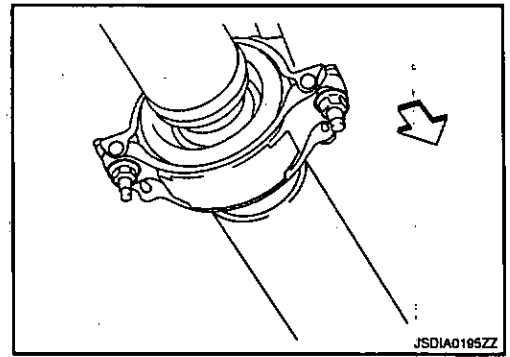

INSTALLATION

Note the following, and install in the reverse order of removal.

- Install center bearing mounting bracket (upper) (1) with its arrow mark (A) facing forward.
- Adjust position of center bearing mounting bracket (1), (2) sliding back and forth to prevent play in thrust direction of center bearing insulator (3). Install center bearing mounting bracket (upper/lower) to vehicle.
- Align matching marks to install propeller shaft assembly to final drive and transfer companion flanges.
- After assembly, perform a driving test to check propeller shaft vibration. If vibration occurred, separate propeller shaft from final drive. Reinstall companion flange after rotating it by 90 and perform driving test to check propeller shaft vibration again at each point. If vibration still exists, repeat the operation rotating the propeller shaft 90 degrees more until vibration disappears or rotating the propeller shaft 270 degrees.

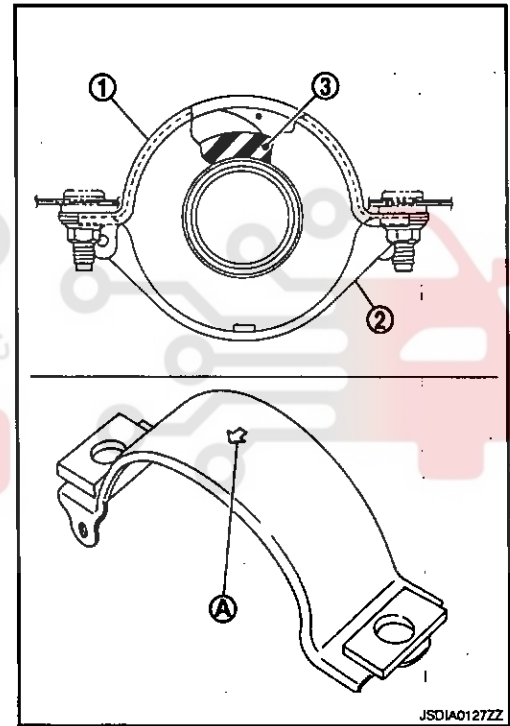

- After tightening the bolts and nuts to the specified torque, make sure that the bolts (3) on the flange side is tightened as shown in the figure.

- 1 : Final drive assembly
- 2 : Propeller shaft assembly

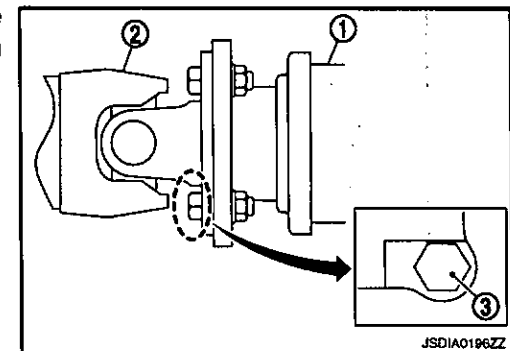

- If propeller shaft assembly or final drive assembly has been replaced, connect them as follows:

REAR PROPELLER SHAFT

[REAR PROPELLER SHAFT: 3F SPL18-DOJ75]

< ON-VEHICLE REPAIR >

- Face the companion flange mark (A) of the final drive (1) upward. With the mark (A) faced upward, couple the propeller shaft and the final drive so that the matching mark (B) of propeller shaft (2) can be positioned as close as possible with the matching mark (C) of the final drive companion flange.
- Push downwards the propeller shaft and, at the same time, tighten mounting bolts and nuts of propeller shaft and final drive to the specified torque.

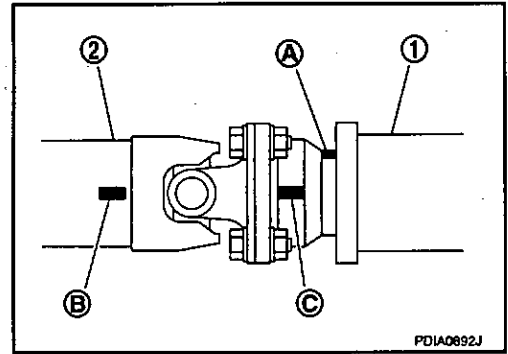

PDA0892J

INFOID:000000004905484

A
B
C

DLN

Inspection

APPEARANCE

Check propeller shaft for bend and damage. If damage is detected, replace propeller shaft assembly.

PROPELLER SHAFT RUNOUT

Check propeller shaft runout at measuring points. If runout exceeds specifications, replace propeller shaft assembly. For measuring point, refer to DLN-104, "Inspection".

Limit

Propeller shaft runout : Refer to DLN-108, "Propeller Shaft Runout".

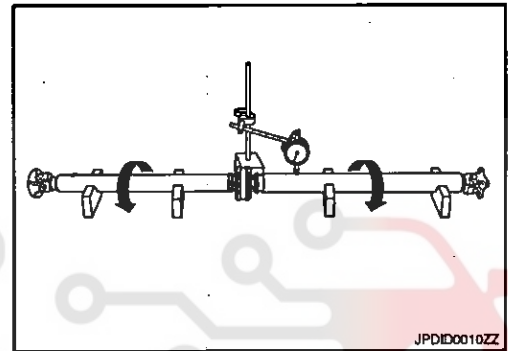

JPDID0010ZZ

E
F
G

H

I

JOURNAL AXIAL PLAY

As shown in the figure, while fixing yoke on one side, check axial play of joint. If outside the standard, replace propeller shaft assembly.

Standard

Journal axial play : Refer to DLN-108, "Journal Axial Play".

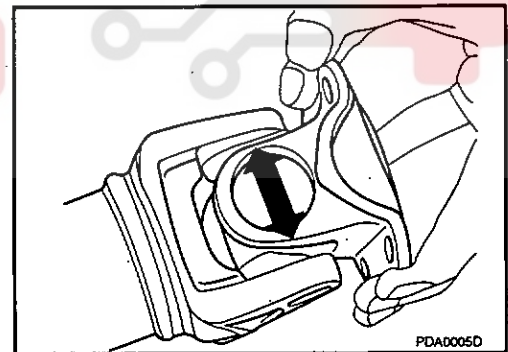

PDA0005D

J
K
L

M

CAUTION:
Never disassemble joints.

CENTER BEARING

Check center bearing for noise and damage. If noise or damage is detected, replace propeller shaft assembly.

CAUTION:
Never disassemble center bearing.

N

O

P

SERVICE DATA AND SPECIFICATIONS (SDS)

< SERVICE DATA AND SPECIFICATIONS (SDS) [REAR PROPELLER SHAFT: 3F SPL18-DOJ75]

SERVICE DATA AND SPECIFICATIONS (SDS)

SERVICE DATA AND SPECIFICATIONS (SDS)

General Specifications

INFOID:000000004905485

Applied model		4WD	
		MR20DE	M9R
		M/T	CVT
Propeller shaft model		3F SPL18-DOJ75	
Number of joints		3	
Type of journal bearings (Non-disassembly type)	1st joint	Cardan type	
	2nd joint	Constant velocity joint (CVJ)	
	3rd joint	Cardan type	
Coupling method with transfer		Flange type	
Coupling method with rear final drive		Flange type	
Shaft length	1st (cardan joint centre to CVJ balls centre)	1091 mm (42.95 in)	1106 mm (43.54 in)
	2nd (CVJ balls centre to cardan joint centre)	831 mm (32.72 in)	827 mm (32.56 in)
Shaft outer diameter	1st	57 mm (2.24 in)	
	2nd	70 mm (2.76 in)	

Propeller Shaft Runout

INFOID:000000004905486

Item	Limit	Unit: mm (in)
Propeller shaft runout	0.6 (0.024)	

Journal Axial Play

INFOID:000000004905487

Item	Standard	Unit: mm (in)
Journal axial play	0 (0)	

< SYMPTOM DIAGNOSIS >

SYMPTOM DIAGNOSIS

NOISE, VIBRATION AND HARSHNESS (NVH) TROUBLESHOOTING

NVH Troubleshooting Chart

INFOID:0000000004905488

Use the chart below to help you find the cause of the symptom. If necessary, repair or replace these parts:

Reference	Possible cause and SUSPECTED PARTS												
	DLN-147, "Inspection After Disassembly"	DLN-144, "Adjustment"	DLN-147, "Inspection After Disassembly"	DLN-144, "Adjustment"	DLN-144, "Adjustment"	DLN-115, "Inspection"	NVH in DLN section	NVH in FAX, RAX, FSU and RSU sections	NVH in WT section	NVH in WT section	NVH in FAX and RAX section	NVH in BR section	NVH in ST section
Possible cause and SUSPECTED PARTS	Gear tooth rough												
	Gear contact improper												
	Tooth surfaces worn												
	Backlash incorrect												
	Companion flange excessive runout												
	Gear oil improper												
	PROPELLER SHAFT												
	AXLE AND SUSPENSION												
	TIRE												
	ROAD WHEEL												
	DRIVE SHAFT												
BRAKE													
STEERING													
Symptom	Noise	x	x	x	x	x	x	x	x	x	x	x	x

x: Applicable

A
B
C
DLN
E
F
G
H
I
J
K
L
M
N
O
P

PRECAUTIONS

< PRECAUTION >

[REAR FINAL DRIVE: R145]

PRECAUTION

PRECAUTIONS

Service Notice or Precautions for Rear Final Drive

INFOID:000000004905489

CAUTION:

- Check for the correct installation status prior to removal or disassembly. If matching marks are required, be certain they do not interfere with the function of the parts when applied.
- Overhaul should be done in a clean work area, it is preferable to work in dustproof area.
- Before disassembly, using steam or white gasoline, completely remove sand and mud from the exterior of the unit, preventing them from entering into the unit during disassembly or assembly.
- Check appearance of the disassembled parts for damage, deformation, and unusual wear. Replace them with a new one if necessary.
- Gaskets, seals and O-rings should be replaced any time when the unit is disassembled.
- In principle, tighten bolts or nuts gradually in several steps working diagonally from inside to outside. If tightening sequence is specified, observe it.
- Clean and flush the parts sufficiently and blow-dry them.
- Be careful not to damage sliding surfaces and mating surfaces.
- When applying sealant, remove the old sealant from the mounting surface; then remove any moisture, oil, and foreign materials from the application and mounting surfaces.
- Always use shop paper for cleaning the inside of components.
- Avoid using cotton gloves or shop rags to prevent entering of lint.
- During assembly, observe the specified tightening torque, and apply new gear oil, petroleum jelly, or multi-purpose grease as specified for each vehicle, if necessary.

دیجیتال خودرو

شرکت دیجیتال خودرو سامانه (مسئولیت محدود)

اولین سامانه دیجیتال تعمیرکاران خودرو در ایران

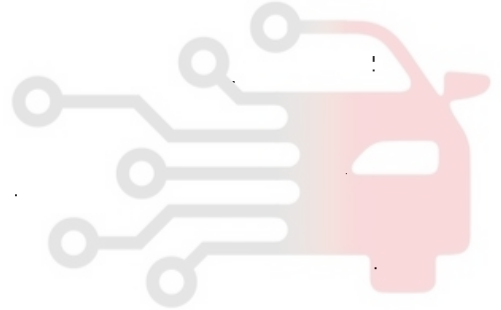

PREPARATION

[REAR FINAL DRIVE: R145]

< PREPARATION >

PREPARATION

PREPARATION

Special Service Tools

INFOID:000000004805490

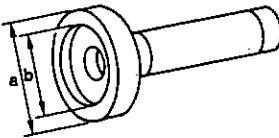
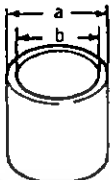
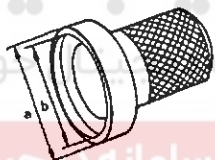
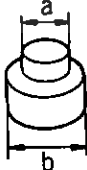
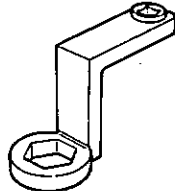
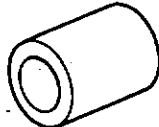
Tool number Tool name	Description
KV38100200 Drift a: 65 mm (2.56 in) dia. b: 49 mm (1.93 in) dia.	 <p>ZZA1143D</p> <ul style="list-style-type: none"> Installing front oil seal Installing side oil seal
ST27861000 Drift a: 62 mm (2.44 in) dia. b: 52 mm (2.05 in) dia.	 <p>ZZA0632D</p> <p>Installing front oil seal</p>
ST35271000 Drift a: 72 mm (2.83 in) dia. b: 63 mm (2.48 in) dia.	 <p>ZZA0814D</p> <p>Installing center oil seal</p>
ST33052000 Drift a: 22 mm (0.87 in) dia. b: 28 mm (1.10 in) dia.	 <p>ZZA1023D</p> <p>Removing side bearing inner race</p>
KV38108400 Pinion nut wrench	 <p>ZZA1206D</p> <p>Removing and installing drive pinion nut</p>
KV38108500 Drive pinion socket	 <p>ZZA1205D</p> <ul style="list-style-type: none"> Removing and installing drive pinion nut Measuring preload torque

A
B
C
DLN
E
F
G
H
I
J
K
L
M
N
O
P

PREPARATION

< PREPARATION >

[REAR FINAL DRIVE: R145]

Tool number Tool name	Description
ST33230000 Drift a: 51 mm (2.01 in) dia. b: 41 mm (1.61 in) dia. c: 28.5 mm (1.122 in) dia.	Installing pinion front bearing outer race
ST23860000 Drift a: 38 mm (1.50 in) dia. b: 33 mm (1.30 in) dia.	<ul style="list-style-type: none"> • Installing pinion rear bearing inner race • Installing pinion front bearing inner race
ST3127S000 Preload gauge	Measuring preload torque
KV389L0010 Dummy cover set	<ul style="list-style-type: none"> • Checking backlash • Checking drive gear runout • Checking tooth contact

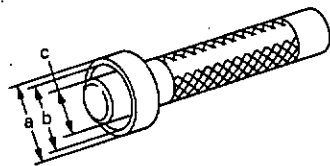

ZZA1046D

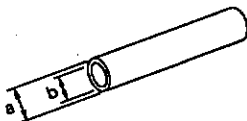

ZZA0534D

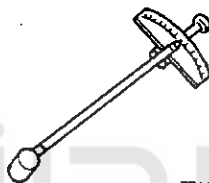

ZZA0503D

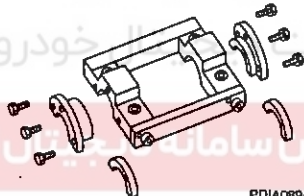

PDIA0894E

Commercial Service Tools

INFOID:0000000004905491

Tool name	Description
Flange wrench	Removing and installing companion flange lock nut
Drift a: 54.5 mm (2.146 in) dia.	Removing and installing gear carrier and rear cover (2 pieces are used)

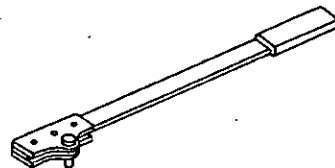

NT771

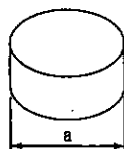

PDIA0893E

PREPARATION

[REAR FINAL DRIVE: R145]

< PREPARATION >

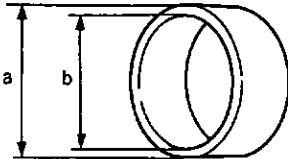
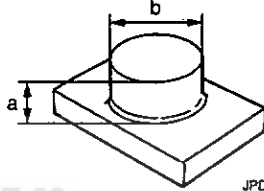
<p>Pin punch a: 4.5 mm (0.177 in) dia.</p>  <p>NT410</p>	<p>Removing and installing lock pin</p>	<p>A B C</p>
<p>Drift a: 39.7 mm (1.563 in) dia. b: 35 mm (1.38 in) dia.</p>  <p>ZZA0936D</p>	<p>Installing side bearing inner race</p>	<p>DLN E</p>
<p>Stand a: Approx. 60 mm (2.36 in) b: Approx. 90 mm (3.54 in) dia</p>  <p>JPDID0011ZZ</p>	<p>Installing pinion front bearing inner race</p>	<p>F G H</p>

دیجیتال خودرو

شرکت دیجیتال خودرو سامانه (مسئولیت محدود)

اولین سامانه دیجیتال تعمیرکاران خودرو در ایران



A
B
C
DLN
E
F
G
H
I
J
K
L
M
N
O
P

REAR FINAL DRIVE ASSEMBLY

< FUNCTION DIAGNOSIS >

[REAR FINAL DRIVE: R145]

FUNCTION DIAGNOSIS
REAR FINAL DRIVE ASSEMBLY

System Diagram

INFOID:000000004905492

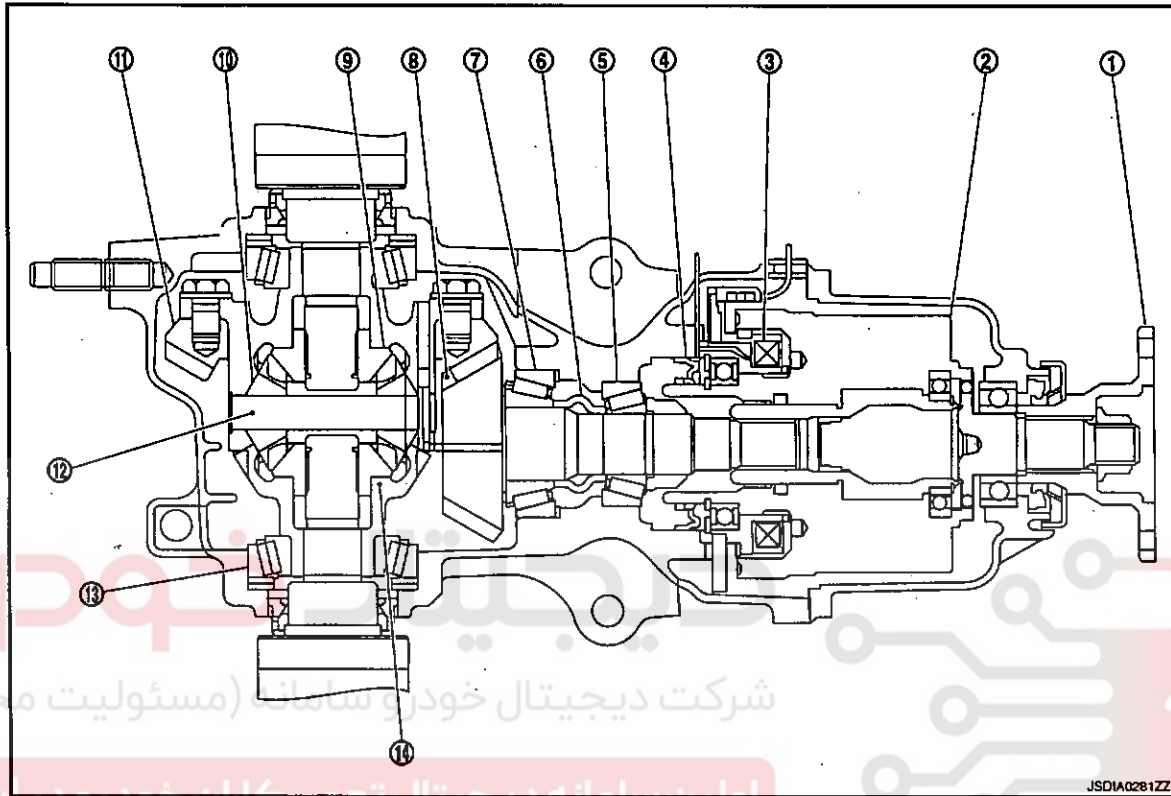

- | | | |
|------------------------|---------------------------------|-----------------------|
| 1. Companion flange | 2. Electric controlled coupling | 3. 4WD solenoid |
| 4. Center oil seal | 5. Pinion front bearing | 6. Collapsible spacer |
| 7. Pinion rear bearing | 8. Drive pinion | 9. Side gear |
| 10. Pinion mate gear | 11. Drive gear | 12. Pinion mate shaft |
| 13. Side bearing | 14. Differential case | |

REAR DIFFERENTIAL GEAR OIL

[REAR FINAL DRIVE: R145]

< ON-VEHICLE MAINTENANCE >

ON-VEHICLE MAINTENANCE

REAR DIFFERENTIAL GEAR OIL

Inspection

INFOID:000000004905493

OIL LEAKAGE

Make sure that oil is not leaking from final drive assembly or around it.

OIL LEVEL

- Remove filler plug (1) and check oil level from filler plug mounting hole as shown in the figure.

CAUTION:

Never start engine while checking oil level.

- Set a new gasket on filler plug and install it on final drive assembly. Refer to DLN-126, "Exploded View".

CAUTION:

Never reuse gasket.

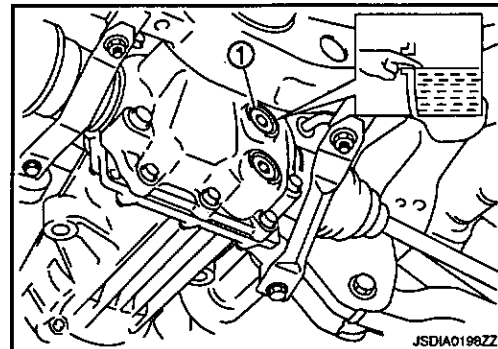

Draining

INFOID:000000004905494

1. Stop engine.
2. Remove drain plug (1) and drain gear oil.
3. Set a new gasket on drain plug and install it to final drive assembly and tighten to the specified torque. Refer to DLN-126, "Exploded View".

CAUTION:

Never reuse gasket.

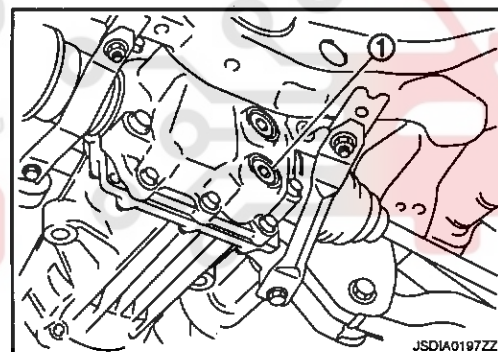

Refilling

INFOID:000000004905495

1. Remove filler plug (1). Fill with new gear oil until oil level reaches the specified level near filler plug mounting hole.

Oil grade and viscosity : Refer to MA-13, "Fluids and Lubricants".

Oil capacity : Refer to DLN-149, "General Specification".

2. After refilling oil, check oil level. Set a new gasket to filler plug, then install it to final drive assembly. Refer to DLN-126, "Exploded View".

CAUTION:

Never reuse gasket.

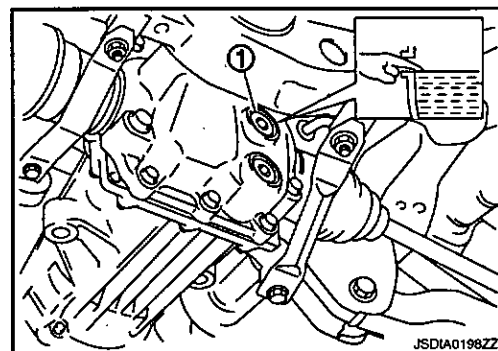

FRONT OIL SEAL

< ON-VEHICLE REPAIR >

[REAR FINAL DRIVE: R145]

ON-VEHICLE REPAIR

FRONT OIL SEAL

Exploded View

INFOID:000000004905496

MR20DE

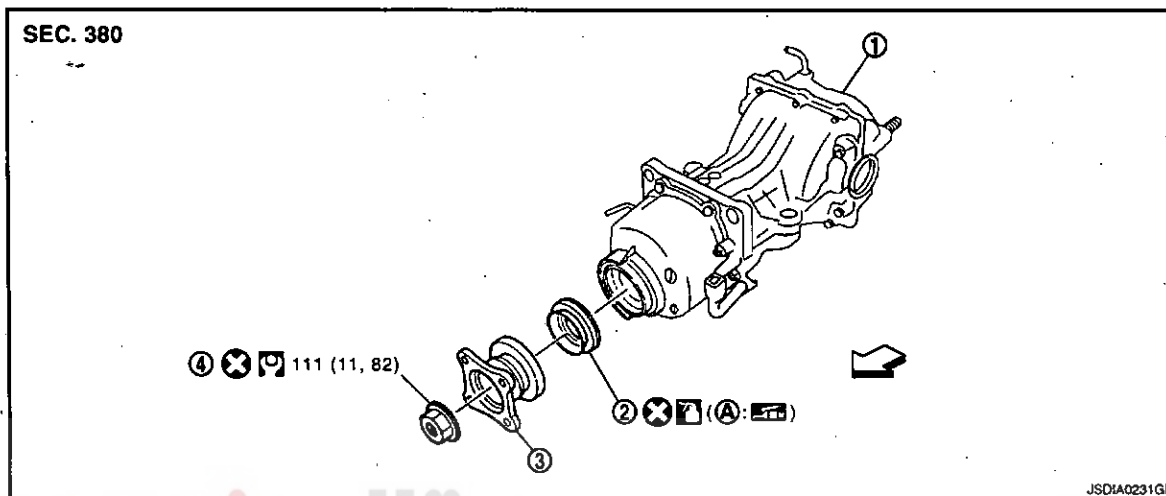

1. Final drive assembly

2. Front oil seal

3. Companion flange

4. Companion flange lock nut

A: Oil seal lip

← Vehicle front

☑ Apply gear oil.

Refer to GI-3, "Components" for symbols not described on the above.

M9R

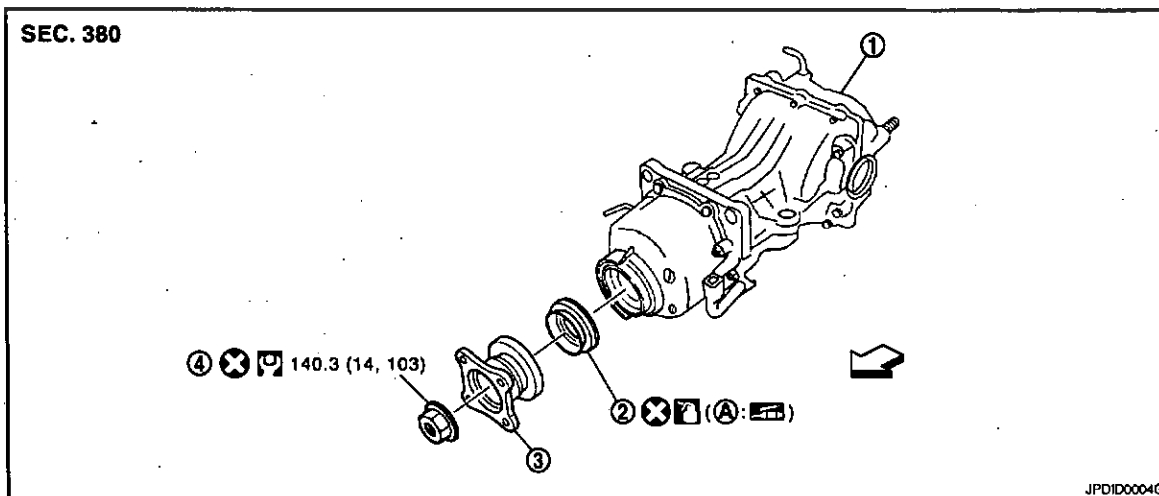

1. Final drive assembly

2. Front oil seal

3. Companion flange

4. Companion flange lock nut

A: Oil seal lip

← Vehicle front

: Apply gear oil.

Refer to GI-3, "Components" for symbols not described on the above.

Removal and Installation

INFOID:000000004905497

REMOVAL

1. Remove rear propeller shaft. Refer to DLN-105, "Exploded View".
2. Put matching mark on the thread edge of electric controlled coupling. The matching mark should be in line with the matching mark on companion flange.

CAUTION:

For matching mark, use paint. Never damage electric controlled coupling.

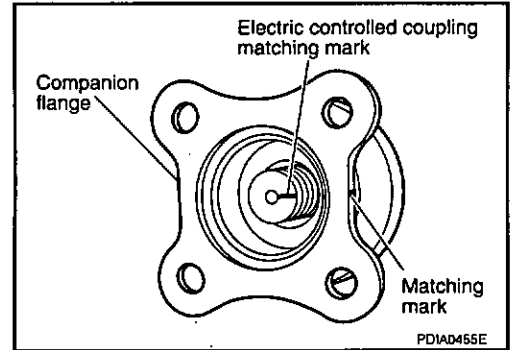

3. Remove companion flange lock nut, using a flange wrench (commercial service tool). Then remove companion flange.

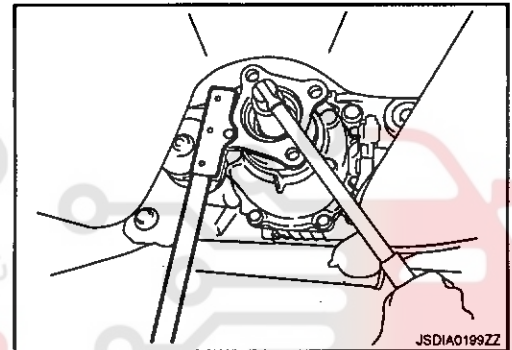

4. Remove front oil seal from coupling cover, using a flat-bladed screwdriver.

CAUTION:

Be careful not to damage coupling cover.

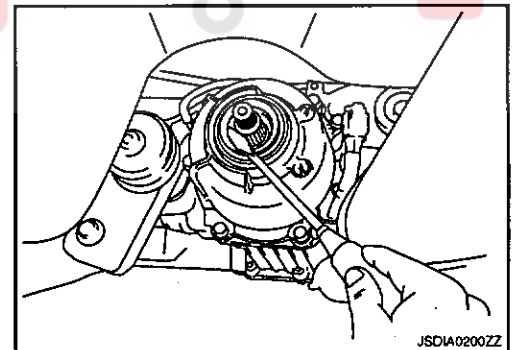

INSTALLATION

1. Install front oil seal until it becomes flush with the coupling cover end, using the drifts.

A : Drift (SST: KV38100200)

B : Drift (SST: ST27861000)

CAUTION:

- Never reuse oil seal.
- When installing, never incline oil seal.
- Apply multi-purpose grease onto oil seal lips, and gear oil onto the circumference of oil seal.

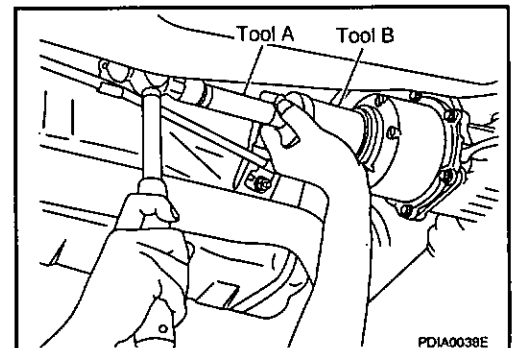

A
B
C
DLN
E
F
G
H
I
J
K
L
M
N
O
P

FRONT OIL SEAL

< ON-VEHICLE REPAIR >

[REAR FINAL DRIVE: R145]

2. Align the matching mark of electric controlled coupling with the matching mark of companion flange, then install the companion flange.
3. Install companion flange lock nut with a flange wrench (commercial service tool), tighten to the specified torque.

CAUTION:**Never reuse companion flange lock nut.**

4. Install rear propeller shaft. Refer to DLN-105, "Exploded View".
5. When oil leaks while removing, check oil level after the installation. Refer to DLN-115, "Inspection".

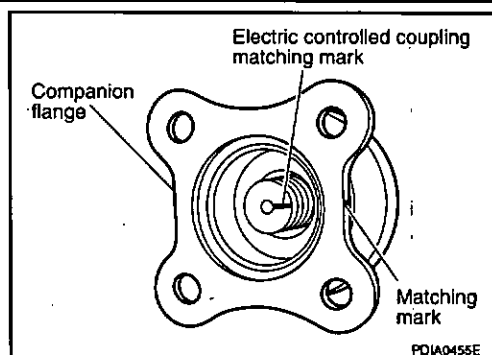

دیجیتال خودرو

شرکت دیجیتال خودرو سامانه (مسئولیت محدود)

اولین سامانه دیجیتال تعمیرکاران خودرو در ایران



< ON-VEHICLE REPAIR >

SIDE OIL SEAL

Exploded View

INFOID:000000004905498

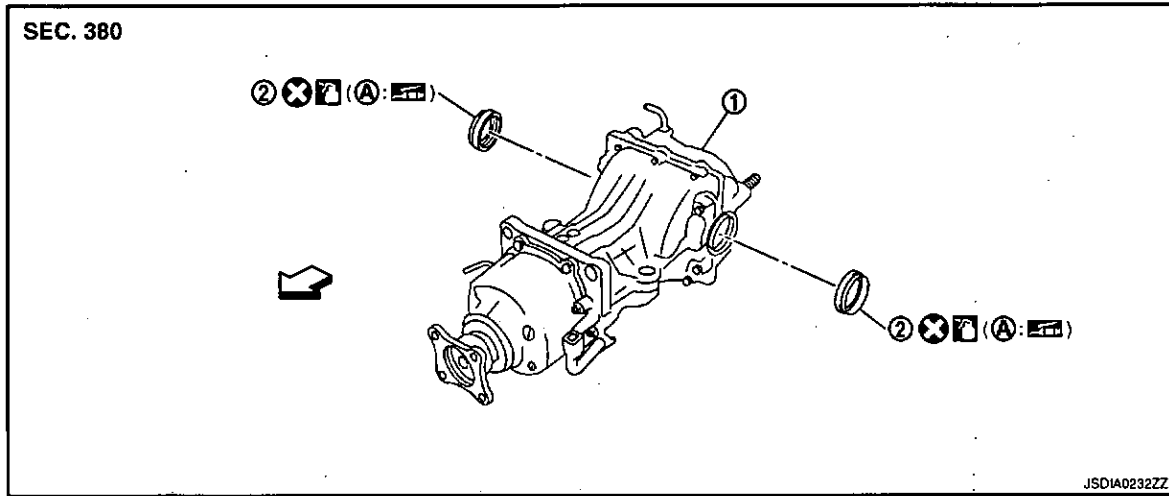

- 1. Final drive assembly
- 2. Side oil seal

A: Oil seal lip

↔: Vehicle front

☒: Apply gear oil.

Refer to GI-3, "Components" for symbols not described on the above.

Removal and Installation

INFOID:000000004905499

REMOVAL اولین سامانه دیجیتال تعمیرکاران خودرو

1. Remove rear drive shafts. Refer to RAX-13, "Exploded View".
2. Remove side oil seals, using a flat-bladed screwdriver.

CAUTION:
Be careful not to damage gear carrier and rear cover.

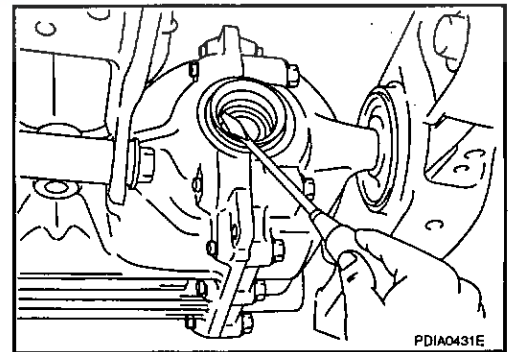

INSTALLATION

1. Install side oil seals until it becomes flush with the carrier end, using the drift (A) (SST: KV38100200).
CAUTION:
 - Never reuse oil seals.
 - When installing, never incline oil seals.
 - Apply multi-purpose grease onto oil seal lips, and gear oil onto the circumference of oil seal.
2. Install rear drive shafts. Refer to RAX-13, "Exploded View".
3. When oil leaks while removing, check oil level after the installation. Refer to DLN-115, "Inspection".

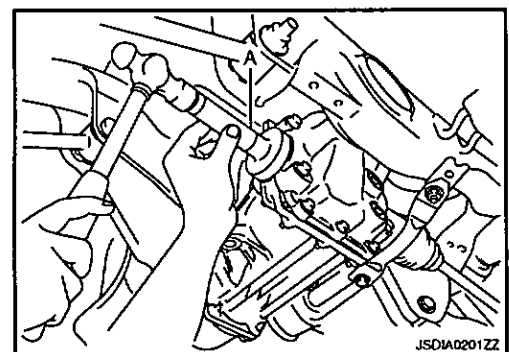

ELECTRIC CONTROLLED COUPLING

< ON-VEHICLE REPAIR >

[REAR FINAL DRIVE: R145]

ELECTRIC CONTROLLED COUPLING

Exploded View

INFOID:000000004905500

MR20DE

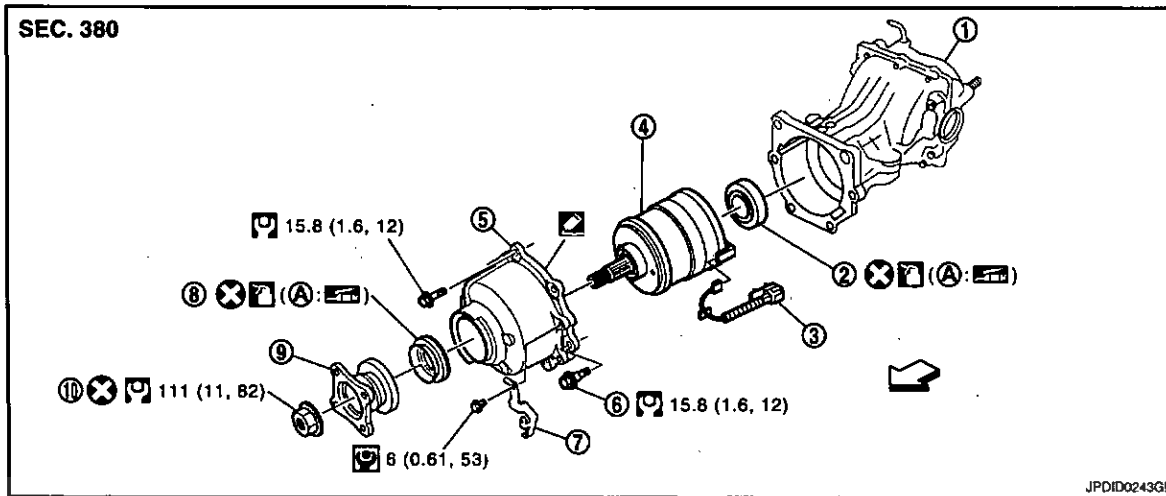

JPDID0243GB

- | | | |
|---------------------------------|--------------------|-------------------------|
| 1. Final drive assembly | 2. Center oil seal | 3. 4WD solenoid harness |
| 4. Electric controlled coupling | 5. Coupling cover | 6. Reamer bolt |
| 7. Connector bracket | 8. Front oil seal | 9. Companion flange |
| 10. Companion flange lock nut | | |

A: Oil seal lip

←: Vehicle front

Apply gear oil.

Apply Genuine Liquid Gasket, Three Bond 1217 or an equivalent.

Refer to GI-3, "Components" for symbols not described on the above.

M9R

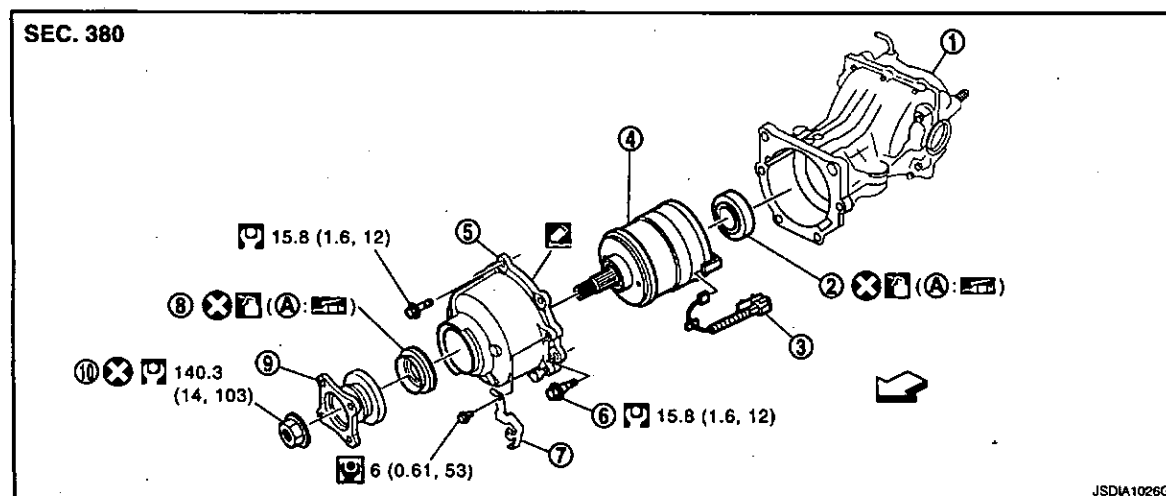

JSDIA1026GB

- | | | |
|---------------------------------|--------------------|-------------------------|
| 1. Final drive assembly | 2. Center oil seal | 3. 4WD solenoid harness |
| 4. Electric controlled coupling | 5. Coupling cover | 6. Reamer bolt |
| 7. Connector bracket | 8. Front oil seal | 9. Companion flange |
| 10. Companion flange lock nut | | |

A: Oil seal lip

ELECTRIC CONTROLLED COUPLING

[REAR FINAL DRIVE: R145]

< ON-VEHICLE REPAIR >

↔: Vehicle front

☑: Apply gear oil.

☑: Apply Genuine Liquid Gasket, Three Bond 1217 or an equivalent.

Refer to GI-3, "Components" for symbols not described on the above.

Removal and Installation

INFOID:000000004905501

REMOVAL

1. Remove rear propeller shaft. Refer to DLN-105, "Exploded View".
2. Disconnect 4WD solenoid harness connector.
3. Remove connector bracket.
4. Put matching mark on the thread edge of electric controlled coupling. The matching mark should be in line with the matching mark on the companion flange.

CAUTION:

For matching mark, use paint. Never damage electric controlled coupling.

NOTE:

When replacing electric controlled coupling, matching mark is not necessary.

5. Remove companion flange lock nut, using a flange wrench (commercial service tool).
6. Remove companion flange.
7. Remove electric controlled coupling breather hose from coupling cover.

8. Remove coupling cover with electric controlled coupling from final drive assembly.
9. Remove electric controlled coupling from coupling cover.
10. Remove 4WD solenoid harness.

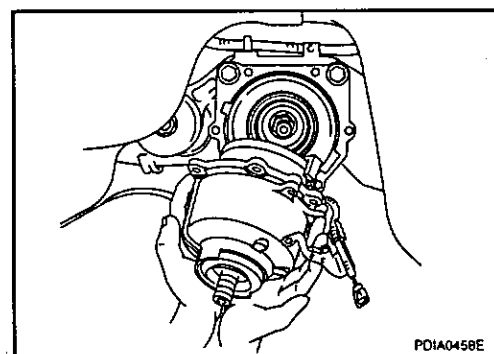
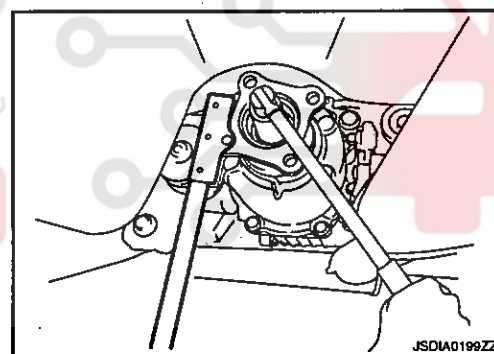
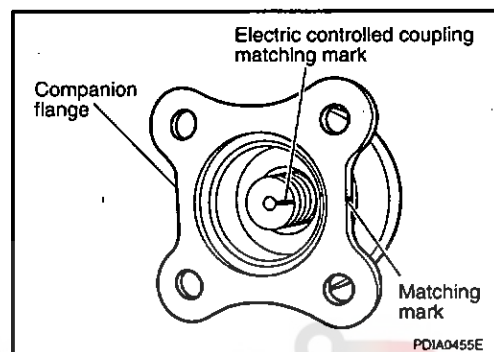

A

B

C

DLN

E

F

G

H

I

J

K

L

M

N

O

P

ELECTRIC CONTROLLED COUPLING

< ON-VEHICLE REPAIR >

[REAR FINAL DRIVE: R145]

- Remove front oil seal from coupling cover, using a flat-bladed screwdriver.
- Remove center oil seal from final drive assembly.

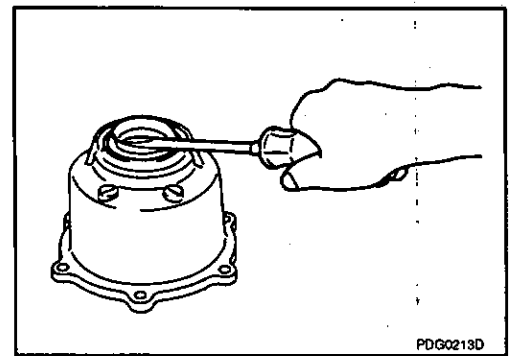

INSTALLATION

- Using the drift (A) (SST: ST35271000), install center oil seal (1) as shown in the figure.

Dimension "D" : 0.8 – 1.2 mm (0.031 – 0.047 in)

CAUTION:

- Never reuse oil seal.
- When installing, never incline oil seal.
- Apply multi-purpose grease onto oil seal lips, and gear oil onto the circumference of oil seal.

- Connect 4WD solenoid harness to electric controlled coupling.

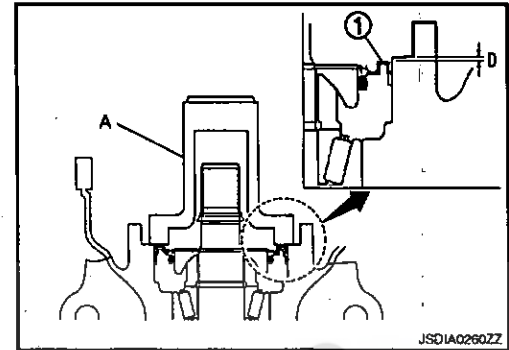

- Install electric controlled coupling to spline of drive pinion inside gear carrier.

CAUTION:

- Align the pin on electric controlled coupling with the groove of gear carrier.
- Be careful not to damage center oil seal.

- Set 4WD solenoid harness guide to gear carrier.

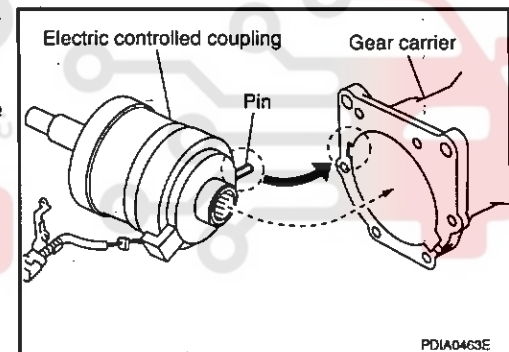

- Using the drifts, drive front oil seal until it becomes flush with the coupling cover end.

A : Drift (SST: KV38100200)

B : Drift (SST: ST27861000)

CAUTION:

- Never reuse oil seal.
- When installing, never incline oil seal.
- Apply multi-purpose grease onto oil seal lips, and gear oil onto the circumference of oil seal.

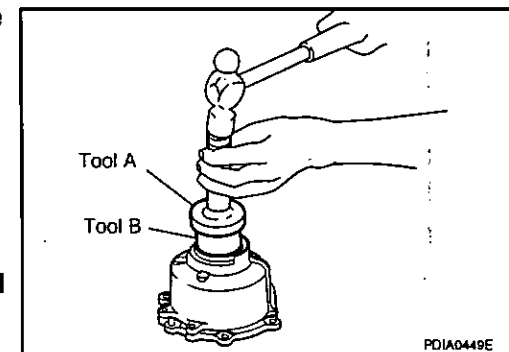

ELECTRIC CONTROLLED COUPLING

[REAR FINAL DRIVE: R145]

< ON-VEHICLE REPAIR >

6. Apply liquid gasket to mating surface of coupling cover. Overlap both ends of the bead for at least 3 mm (0.12 in).

CAUTION:

Remove old gasket adhering to the mounting surfaces. Also remove any moisture, oil, or foreign material adhering to the mounting surfaces.

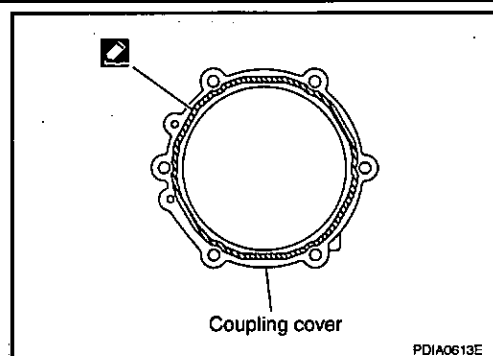

7. Install coupling cover to final drive assembly with arrow facing upward, temporarily tighten reamer bolts to the positions shown in the figure.
8. Tighten reamer bolts and coupling cover mounting bolts to the specified torque.
9. Install electric controlled coupling breather hose to coupling cover.
10. Install connector bracket, and tighten bolts to the specified torque.
11. Connect 4WD solenoid harness connector.

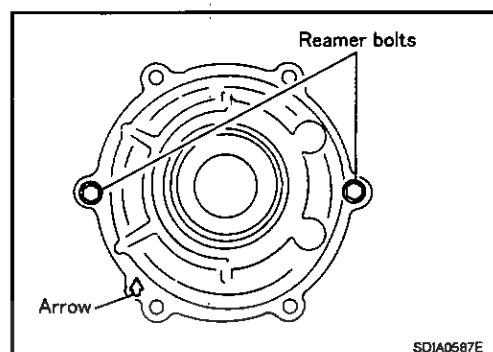

12. Install companion flange.

NOTE:

When reusing electric controlled coupling, align the matching mark of electric controlled coupling with the matching mark of companion flange, then install companion flange.

13. Install companion flange lock nut with flange wrench (commercial service tool), tighten to the specified torque.

CAUTION:

Never reuse companion flange lock nut.

14. Check companion flange runout. Refer to [DLN-130](#), "Adjustment".
15. Install rear propeller shaft. Refer to [DLN-105](#), "Exploded View".
16. When oil leaks while removing, check oil level after the installation. Refer to [DLN-115](#), "Inspection".

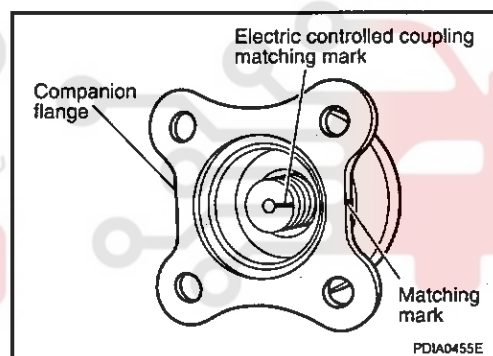

A
B
C
DLN
E
F
G
H
I
J
K
L
M
N
O
P

REAR FINAL DRIVE ASSEMBLY

< REMOVAL AND INSTALLATION >

[REAR FINAL DRIVE: R145]

REMOVAL AND INSTALLATION

REAR FINAL DRIVE ASSEMBLY

Exploded View

INFOID:000000004905502

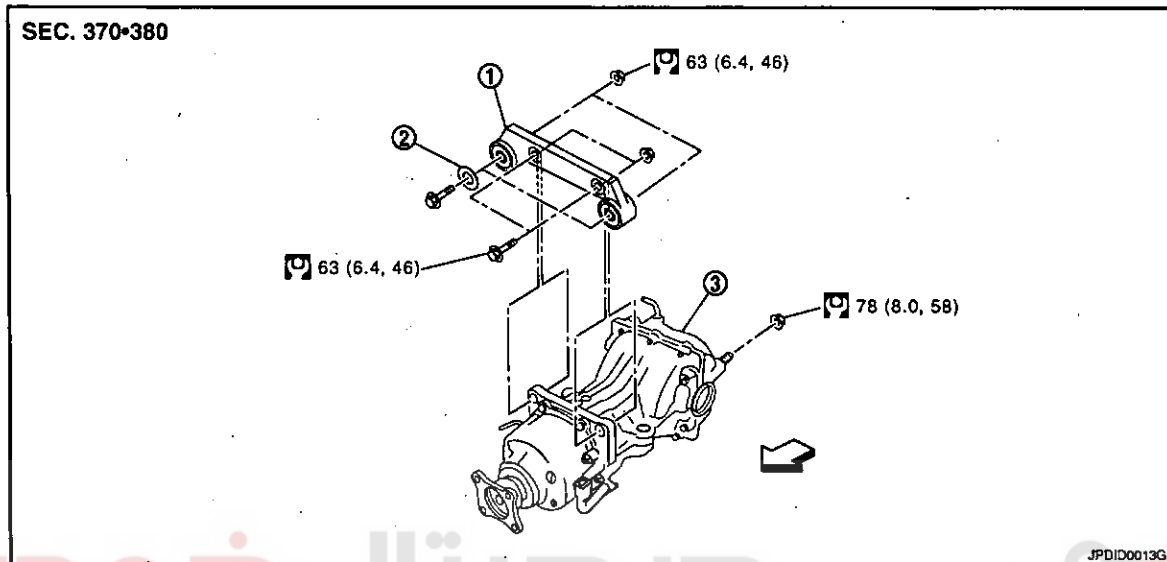

1. Final drive mounting bracket

2. Washer

3. Final drive assembly

← Vehicle front

Refer to GI-3, "Components" for symbols in the figure.

Removal and Installation

INFOID:000000004905503

REMOVAL

1. Remove rear propeller shaft. Refer to DLN-105, "Exploded View".
2. Remove rear drive shafts. Refer to RAX-13, "Exploded View".
3. Disconnect 4WD solenoid harness connector.
4. Remove rear final drive breather hose and electric controlled coupling breather hose.
5. Support final drive assembly with a suitable jack.
6. Remove final drive mounting nuts and final drive mounting bolts.
If necessary, remove final drive mounting bracket.

CAUTION:**Secure final drive assembly to a suitable jack while removing it.**

INSTALLATION

Note the following, and install in the reverse order of removal.

- When installing each breather hoses, refer to the figure and following.

CAUTION:**Make sure there are no pinched or restricted areas on the breather hose caused by bending or winding when installing it.**

REAR FINAL DRIVE ASSEMBLY

[REAR FINAL DRIVE: R145]

< REMOVAL AND INSTALLATION >

- Install rear final drive breather hose (1) to breather connector (2). Install bracket (3) to the breather connector. Check that the paint mark (A) of metal connector (4) faces forward of the vehicle as shown by the arrow.

↔ : Vehicle front

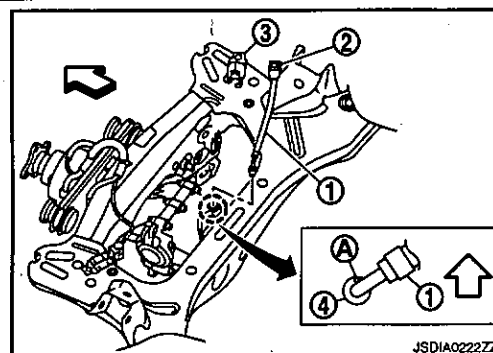

- Install electric controlled coupling breather hose (1) to metal tube all way to the point shown by the solid arrow (↔). Check that the coupling cover (2) of metal tube (3) faces forward of the vehicle as shown by the outline arrow.

↔ : Vehicle front

- When oil leaks while removing final drive assembly, check oil level after the installation. Refer to DLN-115, "Inspection".

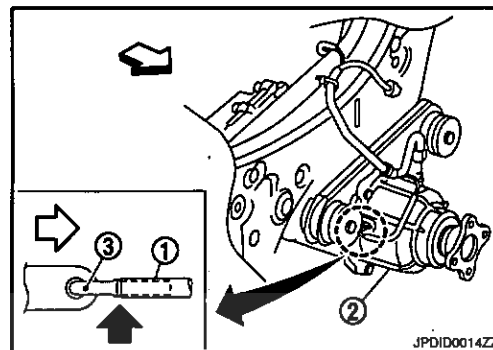

دیجیتال خودرو

شرکت دیجیتال خودرو سامانه (مسئولیت محدود)

اولین سامانه دیجیتال تعمیرکاران خودرو در ایران



A
B
C
DLN
E
F
G
H
I
J
K
L
M
N
O
P

ELECTRIC CONTROLLED COUPLING

< DISASSEMBLY AND ASSEMBLY >

[REAR FINAL DRIVE: R145]

DISASSEMBLY AND ASSEMBLY
ELECTRIC CONTROLLED COUPLING

Exploded View

INFOID:000000004905504

MR20DE

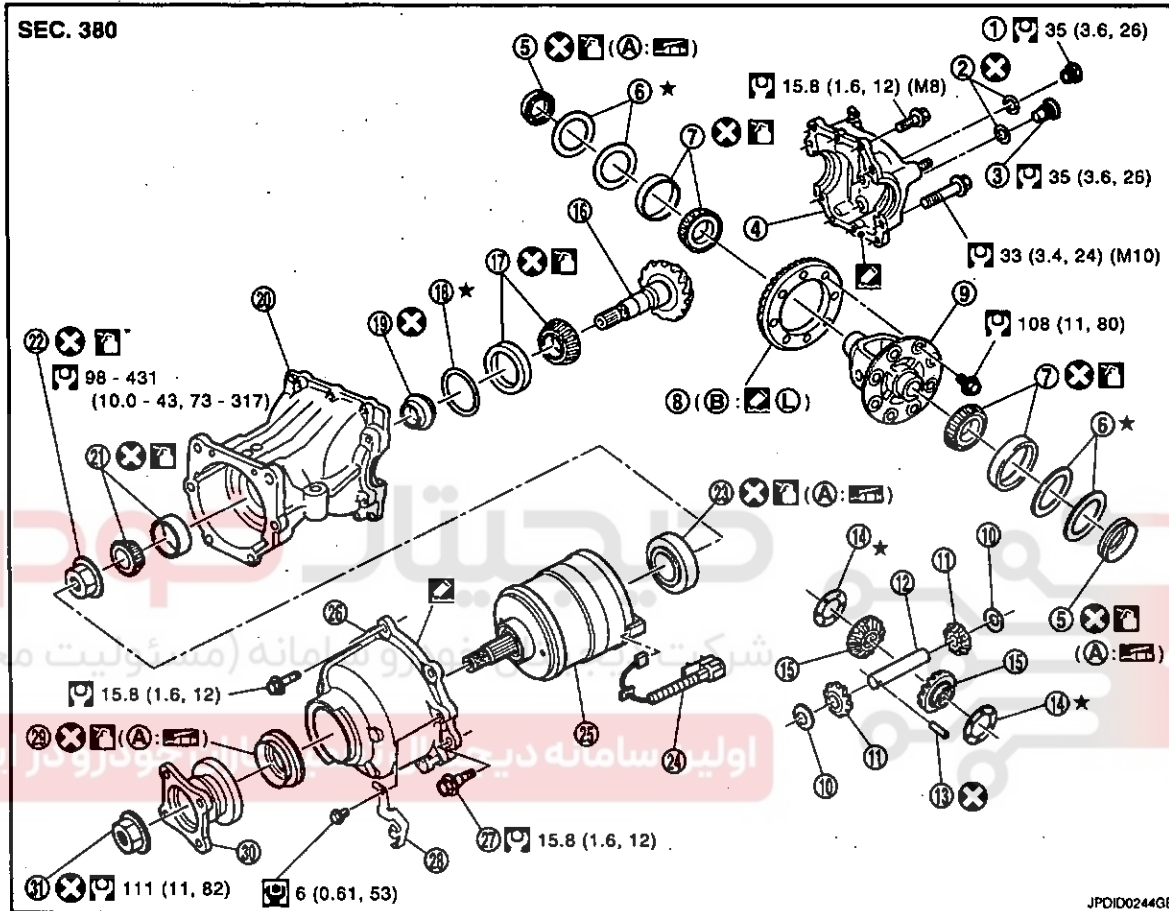

- | | | |
|----------------------------------|-----------------------------|---------------------------------|
| 1. Filler plug | 2. Gasket | 3. Drain plug |
| 4. Rear cover | 5. Side oil seal | 6. Side bearing adjusting shim |
| 7. Side bearing | 8. Drive gear | 9. Differential case |
| 10. Pinion mate thrust washer | 11. Pinion mate gear | 12. Pinion mate shaft |
| 13. Lock pin | 14. Side gear thrust washer | 15. Side gear |
| 16. Drive pinion | 17. Pinion rear bearing | 18. Drive pinion adjusting shim |
| 19. Collapsible spacer | 20. Gear carrier | 21. Pinion front bearing |
| 22. Drive pinion nut | 23. Center oil seal | 24. 4WD solenoid harness |
| 25. Electric controlled coupling | 26. Coupling cover | 27. Reamer bolt |
| 28. Connector bracket | 29. Front oil seal | 30. Companion flange |
| 31. Companion flange lock nut | | |

A: Oil seal lip

B: Screw hole

: Apply gear oil.

: Apply anti-corrosive oil.

: Apply Genuine Liquid Gasket, Three Bond 1217 or an equivalent.

ELECTRIC CONTROLLED COUPLING

< DISASSEMBLY AND ASSEMBLY >

[REAR FINAL DRIVE: R145]

: Apply Genuine Medium Strength Thread Locking Sealant, Three Bond 1322B or an equivalent.
Refer to GI-3. "Components" for symbols not described on the above.

M9R

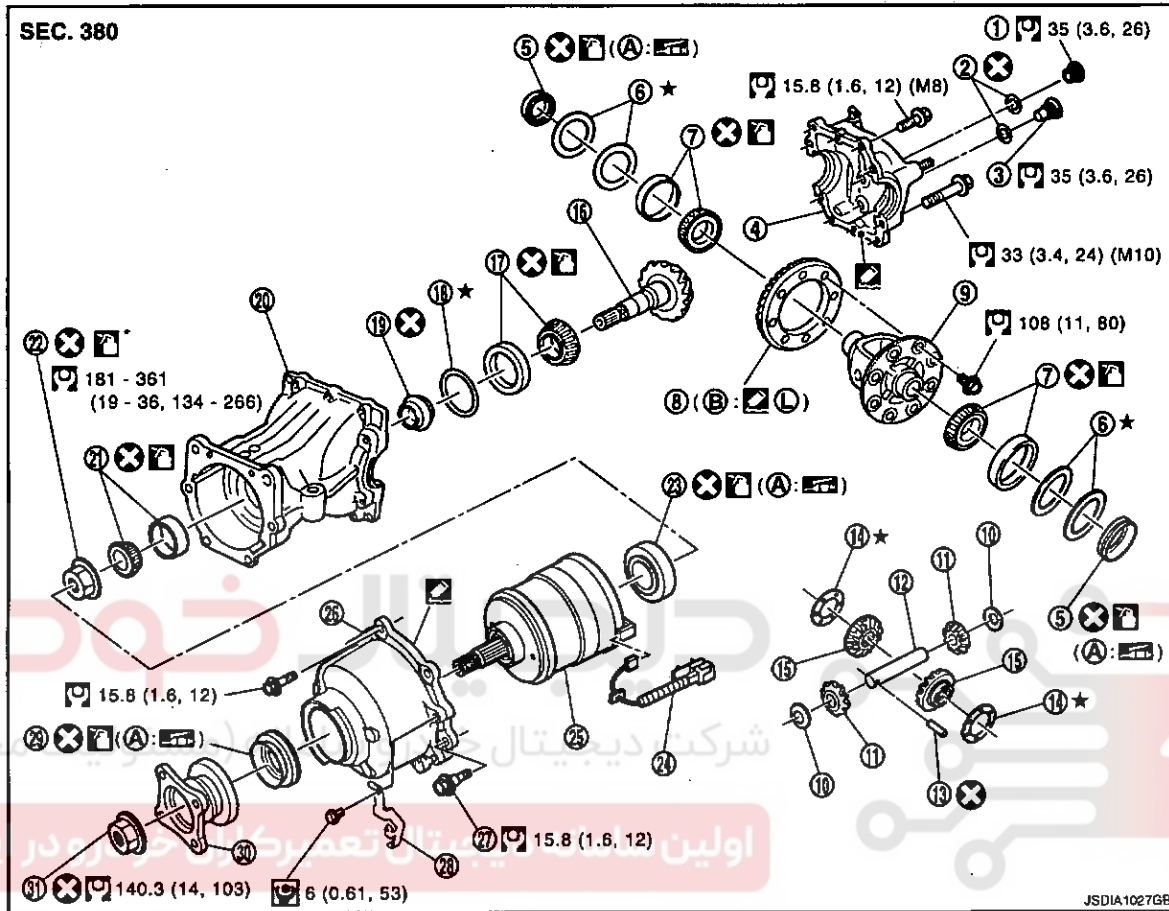

- | | | |
|----------------------------------|-----------------------------|---------------------------------|
| 1. Filler plug | 2. Gasket | 3. Drain plug |
| 4. Rear cover | 5. Side oil seal | 6. Side bearing adjusting shim |
| 7. Side bearing | 8. Drive gear | 9. Differential case |
| 10. Pinion mate thrust washer | 11. Pinion mate gear | 12. Pinion mate shaft |
| 13. Lock pin | 14. Side gear thrust washer | 15. Side gear |
| 16. Drive pinion | 17. Pinion rear bearing | 18. Drive pinion adjusting shim |
| 19. Collapsible spacer | 20. Gear carrier | 21. Pinion front bearing |
| 22. Drive pinion nut | 23. Center oil seal | 24. 4WD solenoid harness |
| 25. Electric controlled coupling | 26. Coupling cover | 27. Reamer bolt |
| 28. Connector bracket | 29. Front oil seal | 30. Companion flange |
| 31. Companion flange lock nut | | |

A: Oil seal lip
B: Screw hole

: Apply gear oil.

*: Apply anti-corrosive oil.

: Apply Genuine Liquid Gasket, Three Bond 1217 or an equivalent.

: Apply Genuine Medium Strength Thread Locking Sealant, Three Bond 1322B or an equivalent.
Refer to GI-3. "Components" for symbols not described on the above.

A
B
C
DLN
E
F
G
H
I
J
K
L
M
N
O
P

ELECTRIC CONTROLLED COUPLING

< DISASSEMBLY AND ASSEMBLY >

[REAR FINAL DRIVE: R145]

Disassembly

INFOID:000000004905505

1. Remove connector bracket.
2. Put matching mark on the thread edge of electric controlled coupling. The matching mark should be in line with the matching mark on companion flange.

CAUTION:

For matching mark, use paint. Never damage electric controlled coupling.

NOTE:

When replacing electric controlled coupling, matching mark is not necessary.

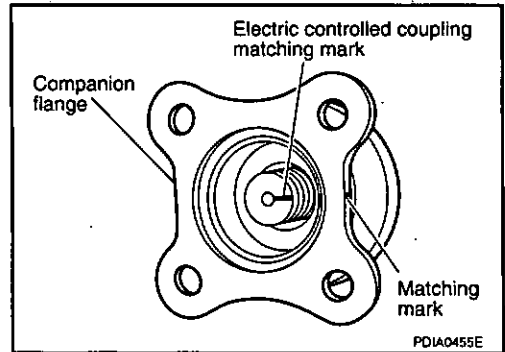

3. Remove companion flange lock nut, using a flange wrench (commercial service tool).
4. Remove companion flange.
5. Remove coupling cover.

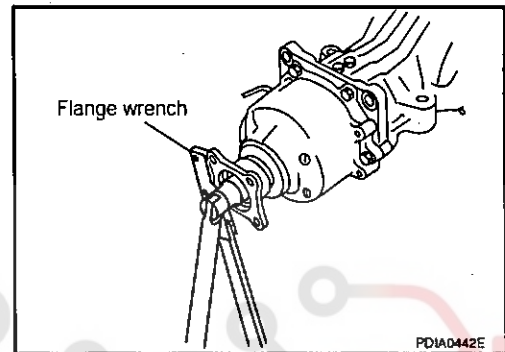

6. Remove front oil seal from coupling cover, using flat-bladed screwdriver.

CAUTION:

Be careful not to damage coupling cover.

7. Remove electric controlled coupling.
8. Remove 4WD solenoid harness.
9. Remove center oil seal from gear carrier.

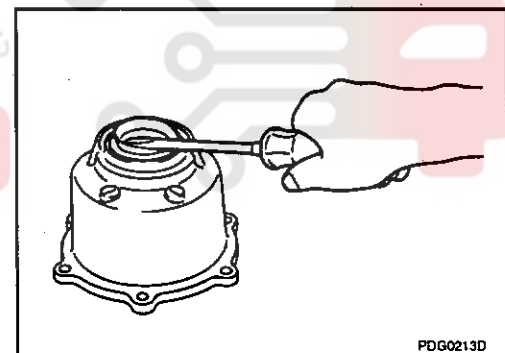

Assembly

INFOID:000000004905506

1. Using the drift (A) (SST: ST35271000), install center oil seal (1) as shown in the figure.

Dimension "D" : 0.8 – 1.2 mm (0.031 – 0.047 in)

CAUTION:

- Never reuse oil seal.
- When installing, never incline oil seal.
- Apply multi-purpose grease onto oil seal lips, and gear oil onto the circumference of oil seal.

2. Connect 4WD solenoid harness to electric controlled coupling.

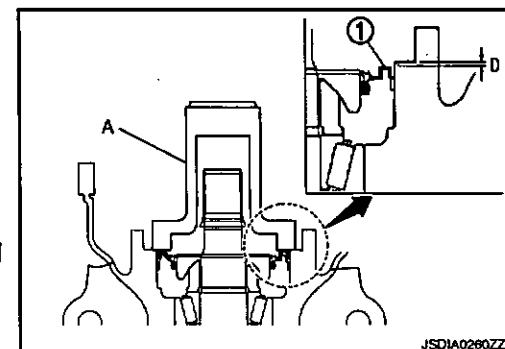

ELECTRIC CONTROLLED COUPLING

[REAR FINAL DRIVE: R145]

< DISASSEMBLY AND ASSEMBLY >

3. Install electric controlled coupling to spline of drive pinion inside gear carrier.
CAUTION:
 - Align the pin on electric controlled coupling with the groove of gear carrier.
 - Be careful not to damage center oil seal.
4. Set 4WD solenoid harness guide to gear carrier.

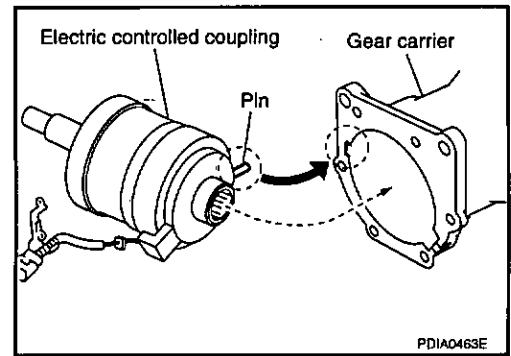

5. Using the drifts, drive front oil seal until it becomes flush with the coupling cover end.

- A : Drift (SST: KV38100200)
- B : Drift (SST: ST27861000)

CAUTION:

- Never reuse oil seal.
- When installing, never incline oil seal.
- Apply multi-purpose grease onto oil seal lips, and gear oil onto the circumference of oil seal.

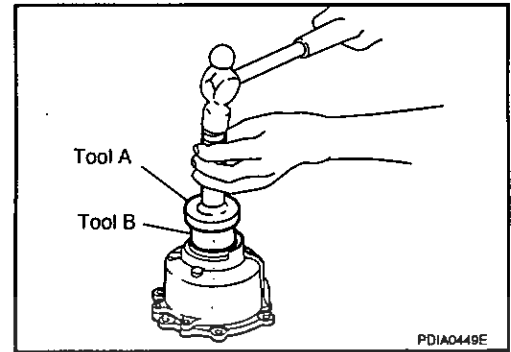

6. Apply liquid gasket to mating surface of coupling cover. Overlap both ends of the bead for at least 3 mm (0.12 in).

CAUTION:

- Remove old gasket adhering to the mounting surfaces.
- Also remove any moisture, oil, or foreign material adhering to the mounting surfaces.

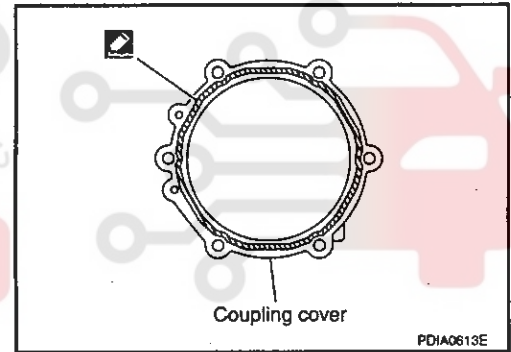

7. Install coupling cover to gear carrier with arrow facing upward, temporarily tighten reamer bolts to the positions shown in the figure.
8. Tighten reamer bolts and coupling cover mounting bolts to the specified torque.
9. Install connector bracket, and tighten bolts to the specified torque.

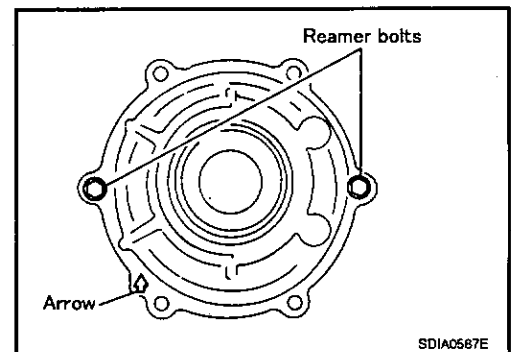

10. Install companion flange.

NOTE:

When reusing electric controlled coupling, align the matching mark of electric controlled coupling with the matching mark of companion flange, then install companion flange.

11. Install companion flange lock nut with flange wrench (commercial service tool), tighten to the specified torque.

CAUTION:

Never reuse companion flange lock nut.

12. Check companion flange runout. Refer to DLN-130, "Adjustment".

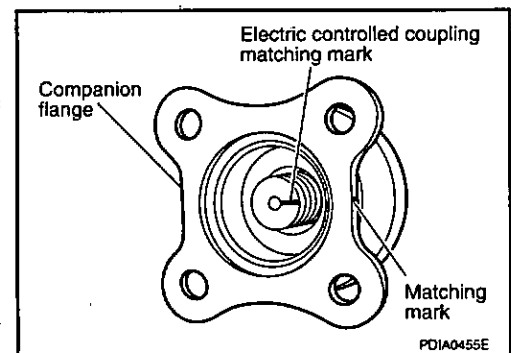

A
B
C
DLN
E
F
G
H
I
J
K
L
M
N
O
P

ELECTRIC CONTROLLED COUPLING

< DISASSEMBLY AND ASSEMBLY >

[REAR FINAL DRIVE: R145]

Adjustment

INFOID:000000004905507

COMPANION FLANGE RUNOUT

1. Fit a dial indicator onto the companion flange face (inner side of the rear propeller shaft mounting bolt holes).
2. Rotate companion flange to check for runout.

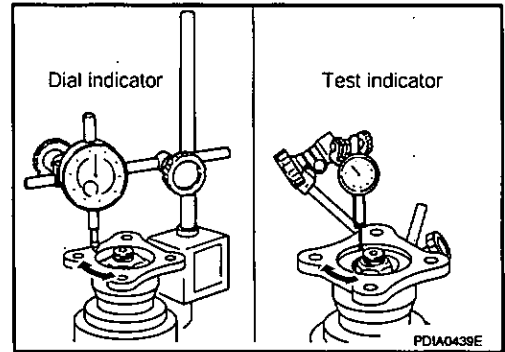

Limit

Companion flange runout : Refer to DLN-149, "Companion Flange Runout".

3. Fit a test indicator to the inner side of companion flange (socket diameter).
4. Rotate companion flange to check for runout.

Limit

Companion flange runout : Refer to DLN-149, "Companion Flange Runout".

5. If the runout value is outside the runout limit, follow the procedure below to adjust.
 - a. Check for runout while changing the phase between companion flange and drive pinion by 90° step, and search for the position where the runout is the minimum.
 - b. If the runout value is still outside of the limit after the phase has been changed, replace companion flange.
 - c. If the runout value is still outside of the limit after companion flange has been replaced, possible cause will be an assembly malfunction of drive pinion and electric controlled coupling, malfunctioning coupling bearing, or malfunctioning of electric controlled coupling.

Inspection After Disassembly

INFOID:000000004905508

Clean up the disassembled parts. Then, inspect if the parts are worn or damaged. If so, follow the measures below.

Content	Conditions and Measures
Hypoid gear	<ul style="list-style-type: none"> • If the gear teeth do not mesh or line-up correctly, determine the cause and adjust or replace as necessary. • If the gears are worn, cracked, damaged, pitted or chipped (by friction) noticeably, replace with new drive gear and drive pinion as a set.
Bearing	If any chipped (by friction), pitted, worn, rusted or scratched mark, or unusual noise from the bearing is observed, replace as a bearing assembly (as a new set).
Side gear and Pinion mate gear	<ul style="list-style-type: none"> • If any cracks or damage on the surface of the tooth is found, replace. • If any worn or chipped mark on the contact sides of the thrust washer is found, replace.
Side gear thrust washer and pinion mate thrust washer	If it is chipped (by friction), damaged, or unusually worn, replace.
Differential case	If any wear or crack on the contact sides of the differential case is found, replace.
Companion flange	If any chipped mark (about 0.1 mm, 0.004 in) or other damage on the contact sides of the lips of the companion flange is found, replace.

DIFFERENTIAL ASSEMBLY

< DISASSEMBLY AND ASSEMBLY >

[REAR FINAL DRIVE: R145]

DIFFERENTIAL ASSEMBLY

Exploded View

INFOID:000000004905509

MR20DE

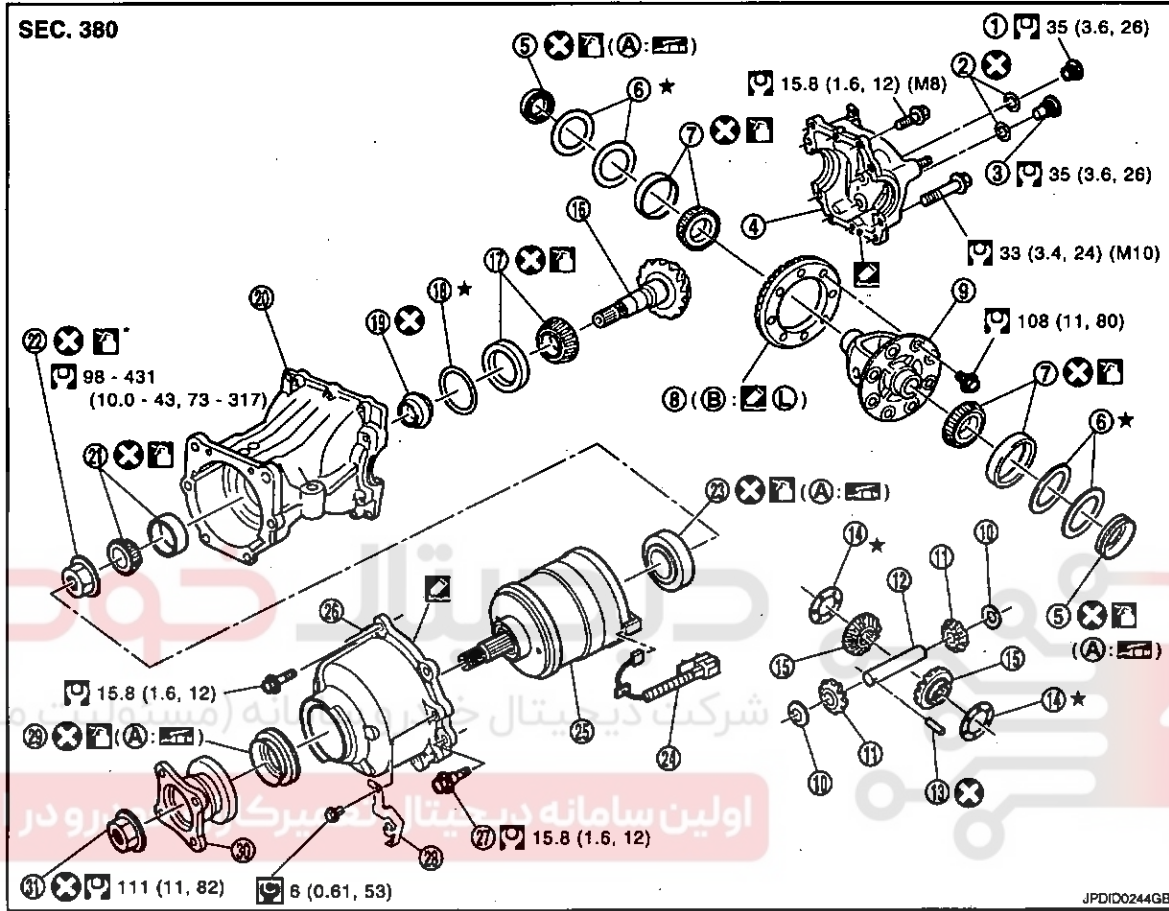

- | | | |
|----------------------------------|-----------------------------|---------------------------------|
| 1. Filler plug | 2. Gasket | 3. Drain plug |
| 4. Rear cover | 5. Side oil seal | 6. Side bearing adjusting shim |
| 7. Side bearing | 8. Drive gear | 9. Differential case |
| 10. Pinion mate thrust washer | 11. Pinion mate gear | 12. Pinion mate shaft |
| 13. Lock pin | 14. Side gear thrust washer | 15. Side gear |
| 16. Drive pinion | 17. Pinion rear bearing | 18. Drive pinion adjusting shim |
| 19. Collapsible spacer | 20. Gear carrier | 21. Pinion front bearing |
| 22. Drive pinion nut | 23. Center oil seal | 24. 4WD solenoid harness |
| 25. Electric controlled coupling | 26. Coupling cover | 27. Reamer bolt |
| 28. Connector bracket | 29. Front oil seal | 30. Companion flange |
| 31. Companion flange lock nut | | |

A: Oil seal lip

B: Screw hole

: Apply gear oil.

: Apply anti-corrosive oil.

: Apply Genuine Liquid Gasket, Three Bond 1217 or an equivalent.

: Apply Genuine Medium Strength Thread Locking Sealant, Three Bond 1322B or an equivalent.

Refer to G-3, "Components" for symbols not described on the above.

DIFFERENTIAL ASSEMBLY

< DISASSEMBLY AND ASSEMBLY >

[REAR FINAL DRIVE: R145]

M9R

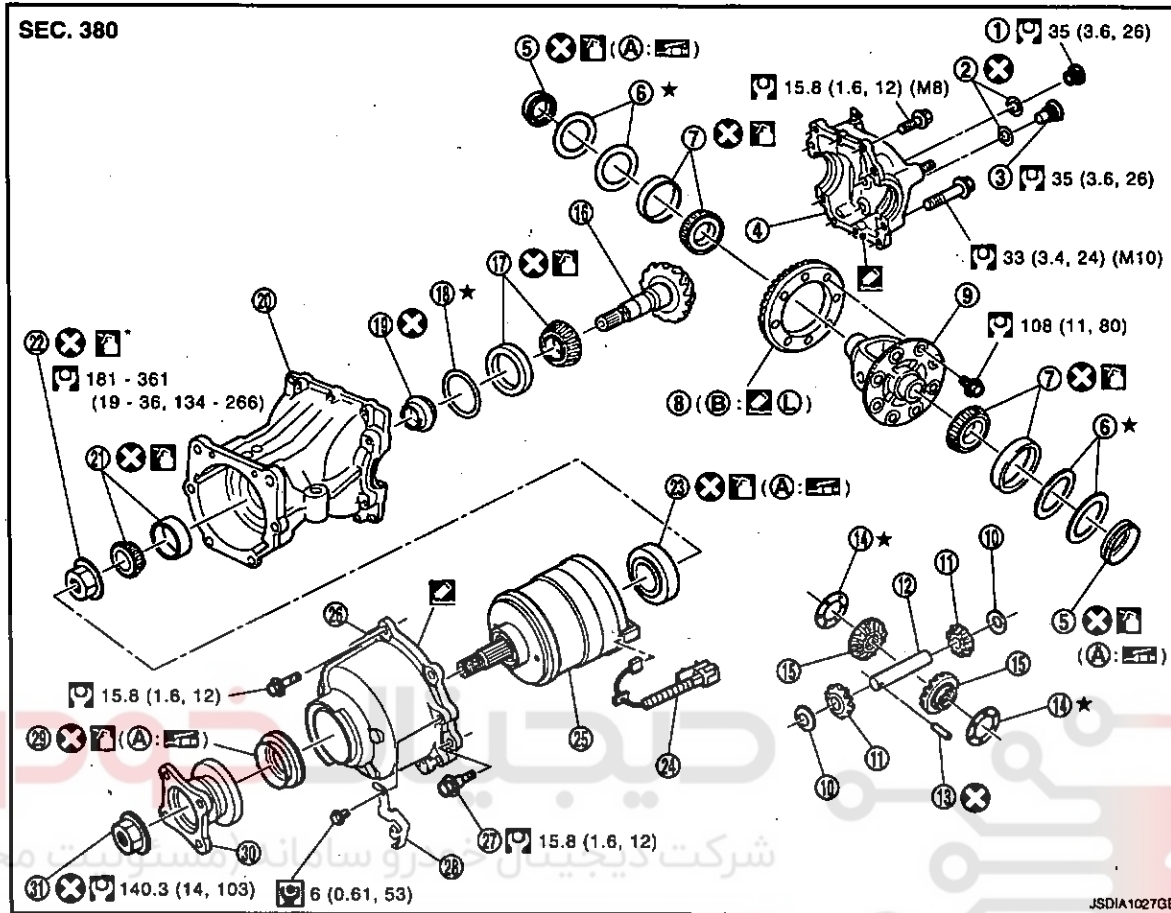

JSDIA1027GB

- | | | |
|----------------------------------|-----------------------------|---------------------------------|
| 1. Filler plug | 2. Gasket | 3. Drain plug |
| 4. Rear cover | 5. Side oil seal | 6. Side bearing adjusting shim |
| 7. Side bearing | 8. Drive gear | 9. Differential case |
| 10. Pinion mate thrust washer | 11. Pinion mate gear | 12. Pinion mate shaft |
| 13. Lock pin | 14. Side gear thrust washer | 15. Side gear |
| 16. Drive pinion | 17. Pinion rear bearing | 18. Drive pinion adjusting shim |
| 19. Collapsible spacer | 20. Gear carrier | 21. Pinion front bearing |
| 22. Drive pinion nut | 23. Center oil seal | 24. 4WD solenoid harness |
| 25. Electric controlled coupling | 26. Coupling cover | 27. Reamer bolt |
| 28. Connector bracket | 29. Front oil seal | 30. Companion flange |
| 31. Companion flange lock nut | | |

A: Oil seal lip

B: Screw hole

: Apply gear oil.

: Apply anti-corrosive oil.

: Apply Genuine Liquid Gasket, Three Bond 1217 or an equivalent.

: Apply Genuine Medium Strength Thread Locking Sealant, Three Bond 1322B or an equivalent.

Refer to GI-3, "Components" for symbols not described on the above.

DIFFERENTIAL ASSEMBLY

< DISASSEMBLY AND ASSEMBLY >

[REAR FINAL DRIVE: R145]

Disassembly

INFOID:000000004905510

1. Remove side oil seals, using flat-bladed screwdriver.
CAUTION:
Be careful not to damage gear carrier and rear cover.
2. Remove rear cover mounting bolts.

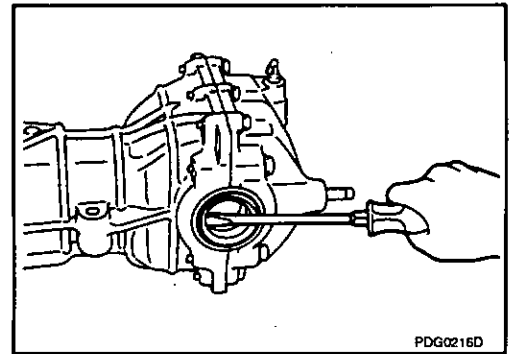

3. Set drifts (commercial service tool) to the right and left side bearing adjusting shims individually. Press differential case assembly with side bearing to remove gear carrier assembly and rear cover assembly.

CAUTION:

The pressure shall be as low as possible to remove gear carrier assembly and rear cover assembly. The maximum pressure shall be 10 kN (1 ton, 1.0 Imp ton).

NOTE:

Differential case assembly, side bearings, and adjusting shims are compressed and integrated in gear carrier and rear cover.

4. Remove drain plug and filler plug.
5. Remove side bearing adjusting shims and side bearing outer races.

CAUTION:

Mark the side bearing adjusting shims so that the original mounting positions (right/left) can be identified later.

6. Remove drive gear mounting bolts and then remove drive gear from differential case.

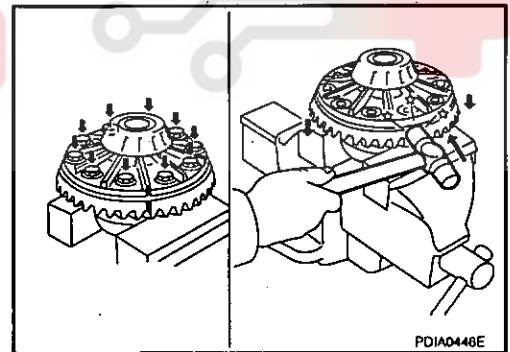
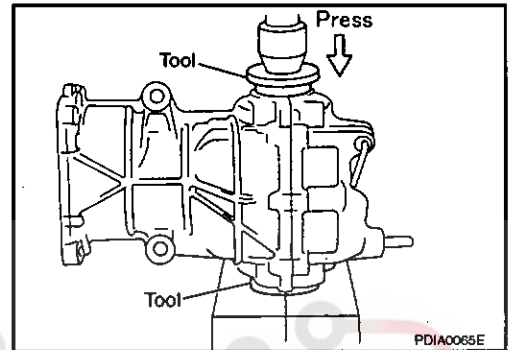

7. Remove side bearing inner races, using pullers and the drift (SST: ST33052000).

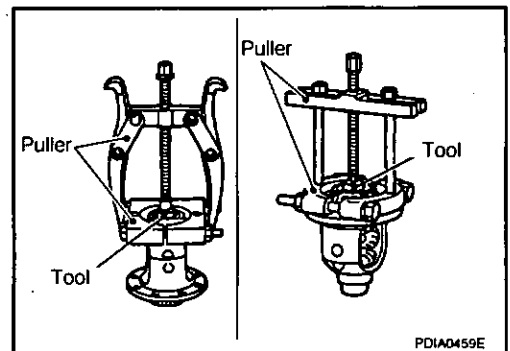

A
B
C
DLN
E
F
G
H
I
J
K
L
M
N
O
P

DIFFERENTIAL ASSEMBLY

< DISASSEMBLY AND ASSEMBLY >

[REAR FINAL DRIVE: R145]

- Pull the lock pin out of pinion mate shaft, using the pin punch (commercial service tool).

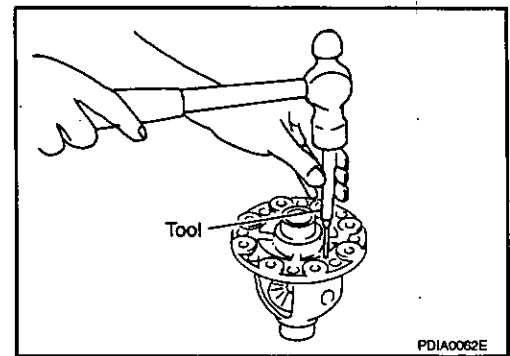

- Remove pinion mate shaft, pinion mate gears, pinion mate thrust washers, side gears, side gear thrust washers from differential case.

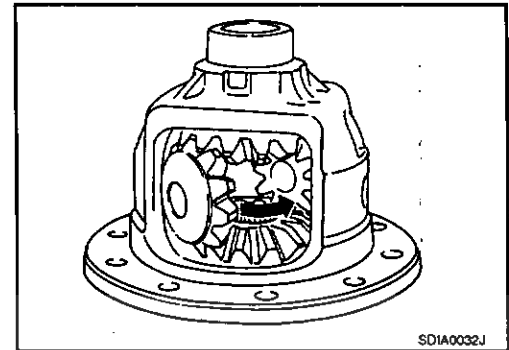

Assembly

- Install side gear thrust washers with the same thickness as the ones installed prior to disassembly or reinstall the old ones on the side gears.
- Install side gears and side gear thrust washers into differential case.

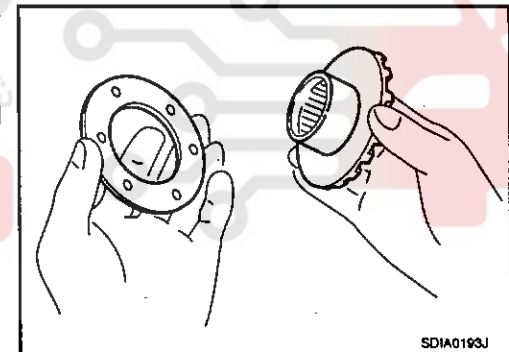

- Align 2 pinion mate gears in diagonally opposite positions, then rotate and install them into differential case after installing pinion mate thrust washer to pinion mate gear.

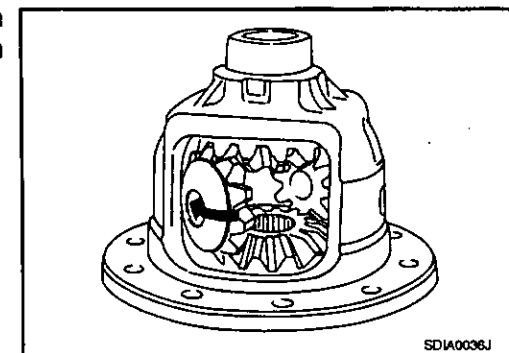

DIFFERENTIAL ASSEMBLY

< DISASSEMBLY AND ASSEMBLY >

[REAR FINAL DRIVE: R145]

- 4. Align the lock pin holes on differential case with shaft, and install pinion mate shaft.

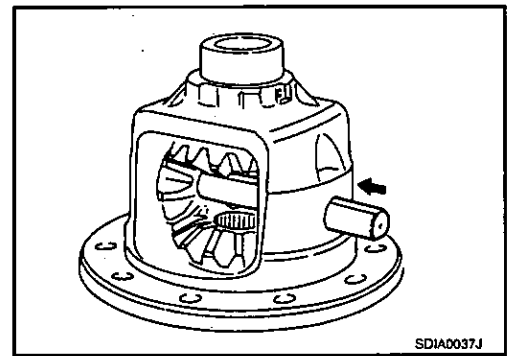

A
B
C

DLN

- 5. Measure side gear end play following the procedure below, and select the appropriate side gear thrust washers.

- a. Place differential case straight up so that side gear to be measured comes upward.

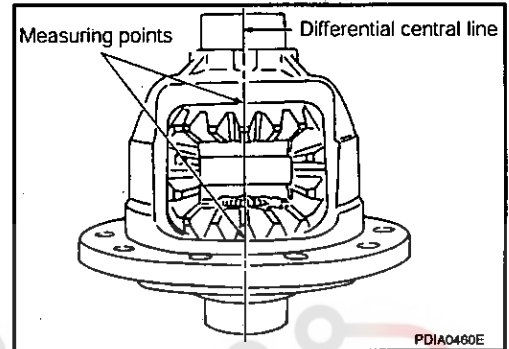

E
F
G
H

- b. Using thickness gauges, measure the clearance between side gear back and differential case at 3 different positions, while rotating side gear. Average the 3 readings, and then measure the clearance. (Measure the clearance of the other side as well.)

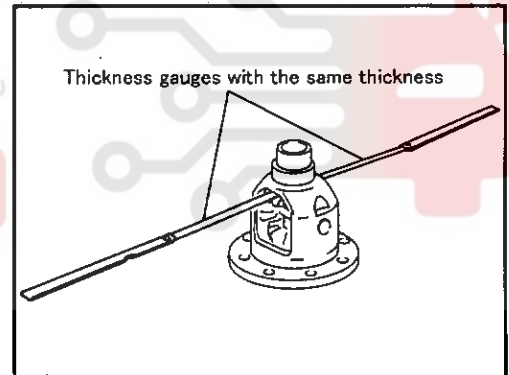

I
J
K
L

Standard

Side gear back clearance : Refer to DLN-149. "Differential Side Gear Clearance".

CAUTION:

To prevent side gear from tilting, insert thickness gauges with the same thickness from both sides.

- c. If the back clearance is outside the specification, use a thicker/thinner side gear thrust washer to adjust.

When the back clearance is large:

Use a thicker thrust washer.

When the back clearance is small:

Use a thinner thrust washer.

CAUTION:

Select a side gear thrust washer for right and left individually.

M
N
O
P

DIFFERENTIAL ASSEMBLY

< DISASSEMBLY AND ASSEMBLY >

[REAR FINAL DRIVE: R145]

6. Drive a lock pin into pinion mate shaft, using the pin punch (commercial service tool).

CAUTION:

Never reuse lock pin.

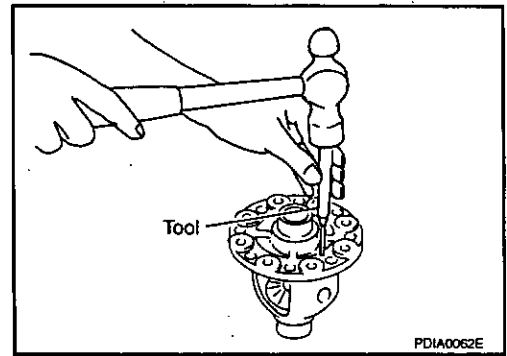

7. Press side bearing inner races to differential case, using the drift (commercial service tool).

CAUTION:

Never reuse side bearing inner races.

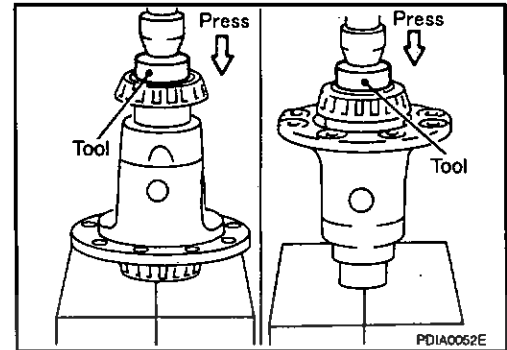

8. Apply locking sealant into the thread hole of drive gear.

CAUTION:

The drive gear back and threaded holes shall be cleaned and decreased sufficiently.

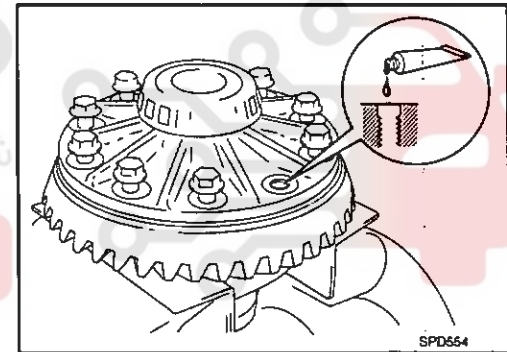

شرکت دیجیتال خودرو سامانه (مسئولیت محدود)

اولین سامانه دیجیتال تعمیرکاران خودرو در ایران

9. Install drive gear to the differential case, and then tighten to the specified torque.

10. Apply gear oil to side bearings, and install new side bearing adjusting shims (2 pieces for one side) with the same thickness as the ones installed prior to disassembly or re-install the old ones, with side bearing outer race to differential case.

If side bearing adjusting shims have been already selected, use them.

CAUTION:

Never reuse side bearing outer race.

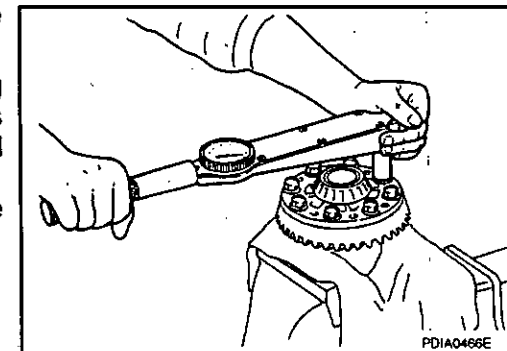

11. Set the drifts (commercial service tool) to the right and left side bearing adjusting shims individually. Compress differential case assembly and side bearing to install gear carrier assembly to differential case assembly.

CAUTION:

- The drift shall be placed on the center of the adjusting shims.
- The pressure shall be as low as possible to install differential assembly into gear carrier assembly. The maximum pressure shall be 10 kN (1 ton, 1.0 Imp ton).
- If the adjusting shims are installed by tapping, the gear carrier may be damaged. Avoid tapping.

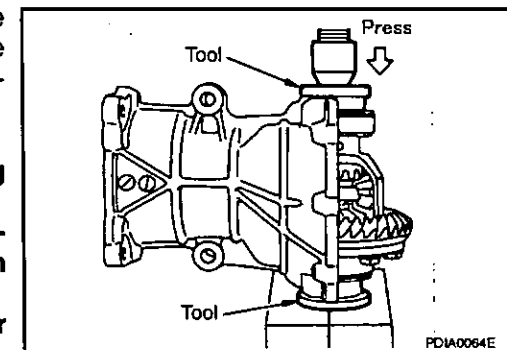

DIFFERENTIAL ASSEMBLY

[REAR FINAL DRIVE: R145]

< DISASSEMBLY AND ASSEMBLY >

- 12. Install dummy cover set, check and adjust drive gear runout, tooth contact, backlash, and total preload torque. Refer to DLN-144, "Adjustment".
- 13. Remove dummy cover set.
- 14. Apply liquid gasket to mating surface of rear cover. Overlap both ends of the bead for at least 3 mm (0.12 in).

CAUTION:

Remove old gasket adhering to the mounting surfaces. Also remove any moisture, oil, or foreign material adhering to the mounting surfaces.

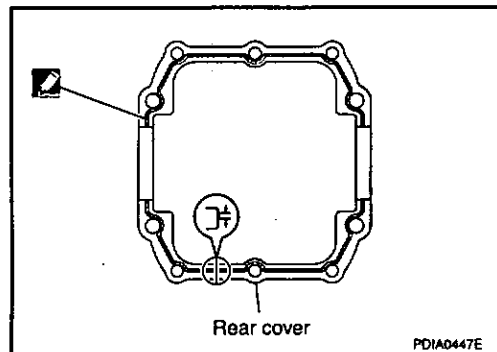

- 15. Set the drifts (commercial service tool) to the right and left side bearing adjusting shims individually. Compress differential case assembly and side bearing to install rear cover.

CAUTION:

- The drift shall be placed on the center of the adjusting shims.
- The pressure shall be as low as possible to install the rear cover. The maximum pressure shall be 10 kN (1 ton, 1.0 Imp ton).
- If rear cover is forced in by tapping, rear cover may be damaged by adjusting shims. Avoid tapping.

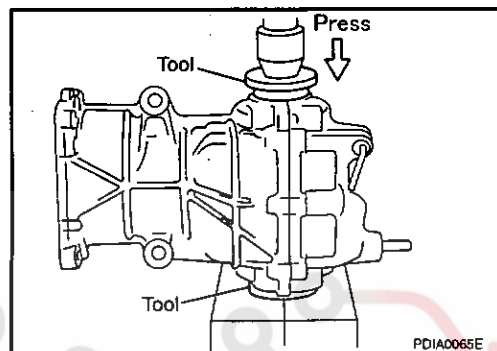

- 16. Tighten rear cover mounting bolts to the specified torque.
- 17. Using the drift (SST: KV38100200), drive side oil seals until it becomes flush with the carrier end.

CAUTION:

- Never reuse oil seals.
- When installing, do not incline oil seals.
- Apply multi-purpose grease onto oil seal lips, and gear oil onto the circumference of oil seal.

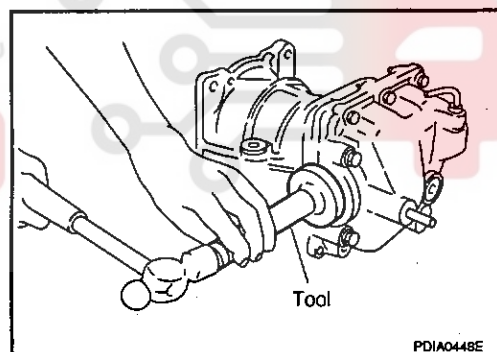

- 18. Check total preload torque. Refer to DLN-144, "Adjustment".

Inspection After Disassembly

INFOID:000000004905512

Clean up the disassembled parts. Then, inspect if the parts are worn or damaged. If so, follow the measures below.

Content	Conditions and Measures
Hypoid gear	<ul style="list-style-type: none"> • If the gear teeth do not mesh or line-up correctly, determine the cause and adjust or replace as necessary. • If the gears are worn, cracked, damaged, pitted or chipped (by friction) noticeably, replace with new drive gear and drive pinion as a set.
Bearing	If any chipped (by friction), pitted, worn, rusted or scratched mark, or unusual noise from the bearing is observed, replace as a bearing assembly (as a new set).
Side gear and Pinion mate gear	<ul style="list-style-type: none"> • If any cracks or damage on the surface of the tooth is found, replace. • If any worn or chipped mark on the contact sides of the thrust washer is found, replace.
Side gear thrust washer and pinion mate thrust washer	If it is chipped (by friction), damaged, or unusually worn, replace.
Differential case	If any wear or crack on the contact sides of the differential case is found, replace.
Companion flange	If any chipped mark (about 0.1 mm, 0.004 in) or other damage on the contact sides of the lips of the companion flange is found, replace.

DRIVE PINION

< DISASSEMBLY AND ASSEMBLY >

[REAR FINAL DRIVE: R145]

DRIVE PINION

Exploded View

INFOID:000000004905513

MR20DE

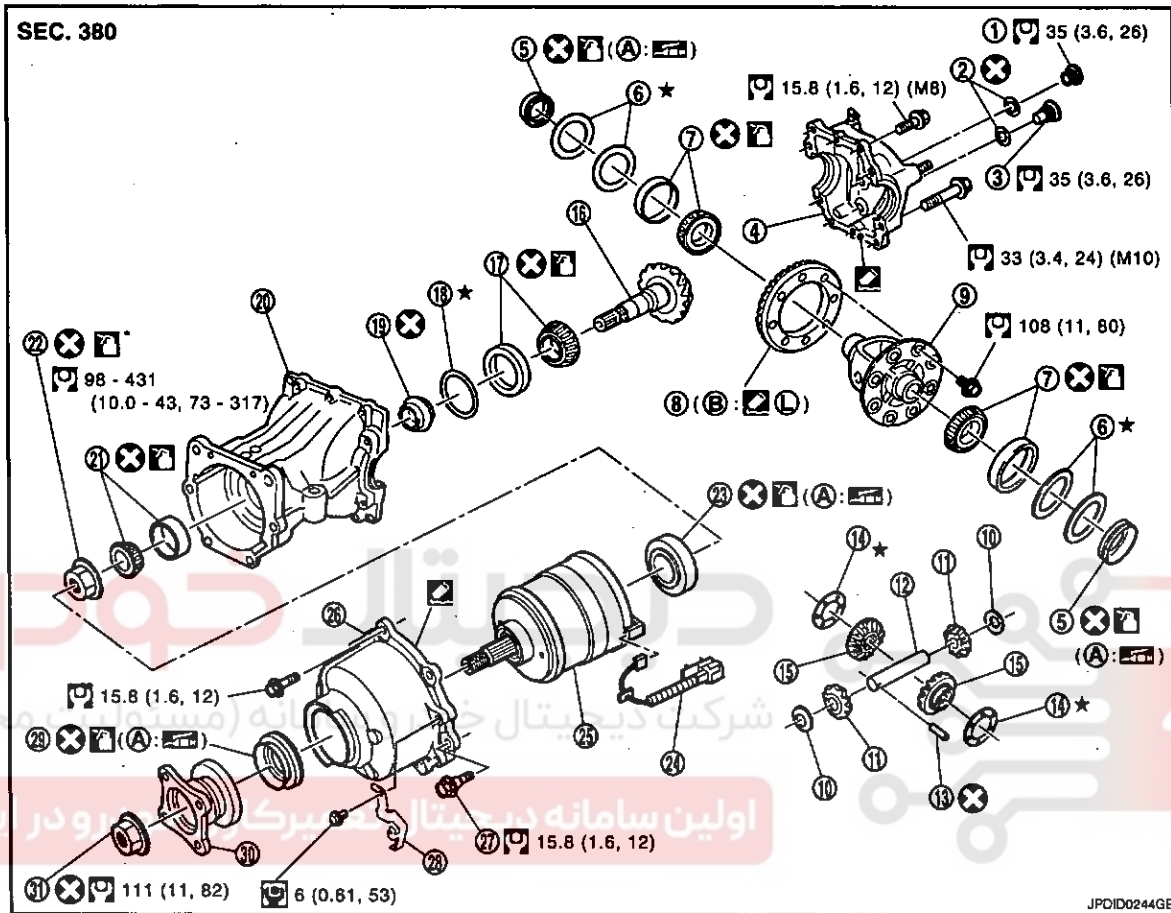

- | | | |
|----------------------------------|-----------------------------|---------------------------------|
| 1. Filler plug | 2. Gasket | 3. Drain plug |
| 4. Rear cover | 5. Side oil seal | 6. Side bearing adjusting shim |
| 7. Side bearing | 8. Drive gear | 9. Differential case |
| 10. Pinion mate thrust washer | 11. Pinion mate gear | 12. Pinion mate shaft |
| 13. Lock pin | 14. Side gear thrust washer | 15. Side gear |
| 16. Drive pinion | 17. Pinion rear bearing | 18. Drive pinion adjusting shim |
| 19. Collapsible spacer | 20. Gear carrier | 21. Pinion front bearing |
| 22. Drive pinion nut | 23. Center oil seal | 24. 4WD solenoid harness |
| 25. Electric controlled coupling | 26. Coupling cover | 27. Reamer bolt |
| 28. Connector bracket | 29. Front oil seal | 30. Companion flange |
| 31. Companion flange lock nut | | |

A: Oil seal lip

B: Screw hole

: Apply gear oil.

: Apply anti-corrosive oil.

: Apply Genuine Liquid Gasket, Three Bond 1217 or an equivalent.

: Apply Genuine Medium Strength Thread Locking Sealant, Three Bond 1322B or an equivalent.

Refer to GI-3, "Components" for symbols not described on the above.

DRIVE PINION

< DISASSEMBLY AND ASSEMBLY >

[REAR FINAL DRIVE: R145]

M9R

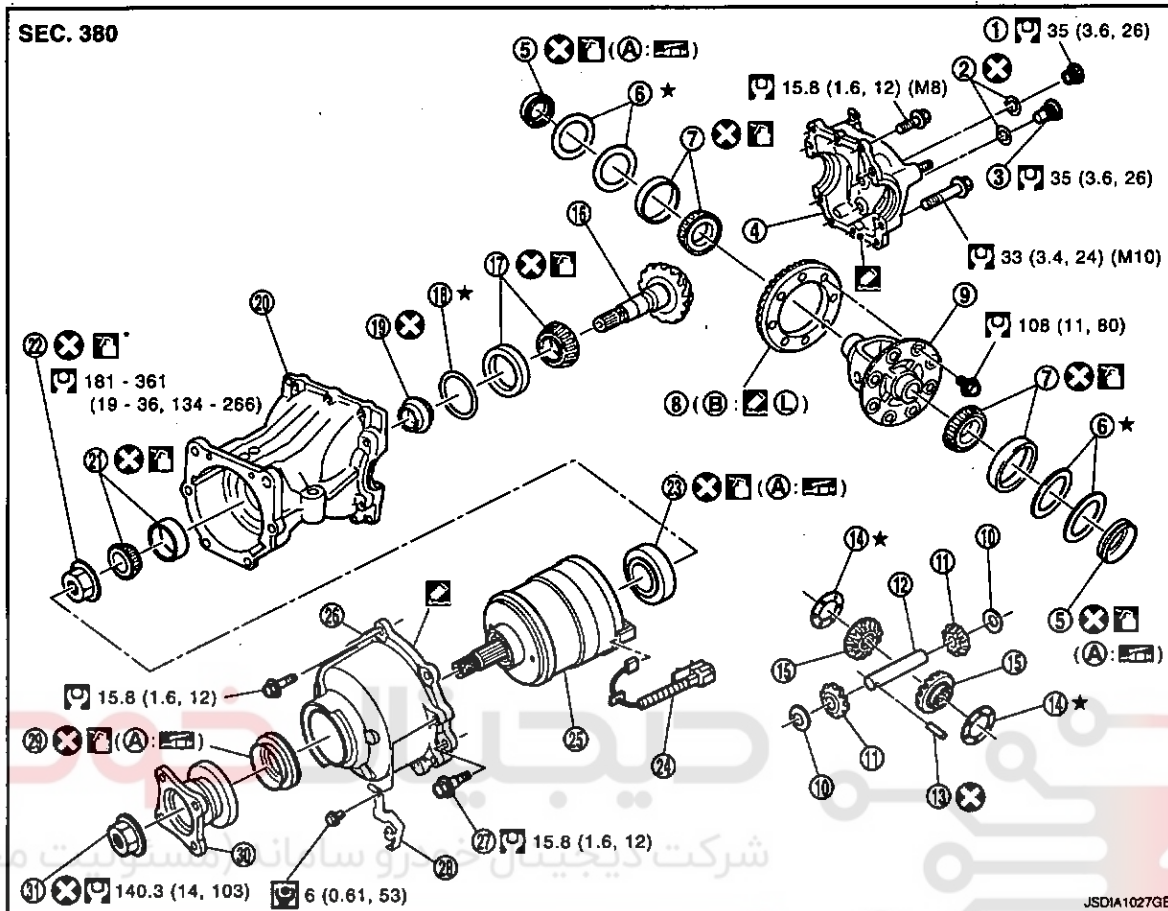

A
B
C
DLN
E
F
G
H
I
J
K
L
M
N
O
P

- | | | |
|----------------------------------|-----------------------------|---------------------------------|
| 1. Filler plug | 2. Gasket | 3. Drain plug |
| 4. Rear cover | 5. Side oil seal | 6. Side bearing adjusting shim |
| 7. Side bearing | 8. Drive gear | 9. Differential case |
| 10. Pinion mate thrust washer | 11. Pinion mate gear | 12. Pinion mate shaft |
| 13. Lock pin | 14. Side gear thrust washer | 15. Side gear |
| 16. Drive pinion | 17. Pinion rear bearing | 18. Drive pinion adjusting shim |
| 19. Collapsible spacer | 20. Gear carrier | 21. Pinion front bearing |
| 22. Drive pinion nut | 23. Center oil seal | 24. 4WD solenoid harness |
| 25. Electric controlled coupling | 26. Coupling cover | 27. Reamer bolt |
| 28. Connector bracket | 29. Front oil seal | 30. Companion flange |
| 31. Companion flange lock nut | | |

A: Oil seal lip
B: Screw hole

- : Apply gear oil.
 - : Apply anti-corrosive oil.
 - : Apply Genuine Liquid Gasket, Three Bond 1217 or an equivalent.
 - : Apply Genuine Medium Strength Thread Locking Sealant, Three Bond 1322B or an equivalent.
- Refer to GI-3, "Components" for symbols not described on the above.

Disassembly

1. Remove electric controlled coupling assembly. Refer to DLN-128, "Disassembly".
2. Remove differential case assembly. Refer to DLN-133, "Disassembly".

INFOID:000000004905514

DRIVE PINION

< DISASSEMBLY AND ASSEMBLY >

[REAR FINAL DRIVE: R145]

- Fit drive pinion socket (A) (SST: KV38108500) onto drive pinion spline. Remove drive pinion nut, using the pinion nut wrench (B) (SST: KV38108400).

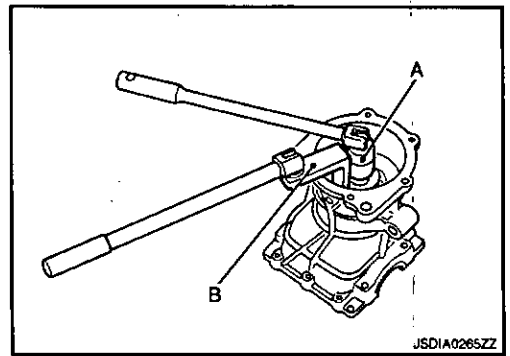

- Press drive pinion assembly out of gear carrier.

CAUTION:

Never drop drive pinion assembly.

- Remove pinion front bearing inner race.
- Remove collapsible spacer.

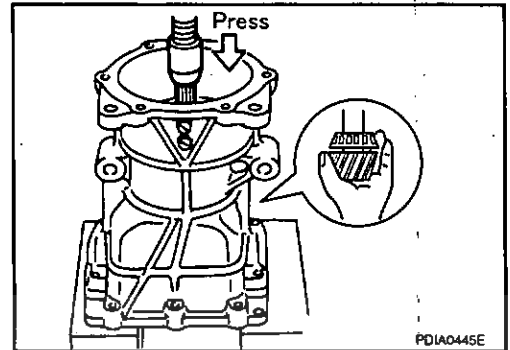

- Remove pinion rear bearing inner race from drive pinion, using puller and bearing puller.

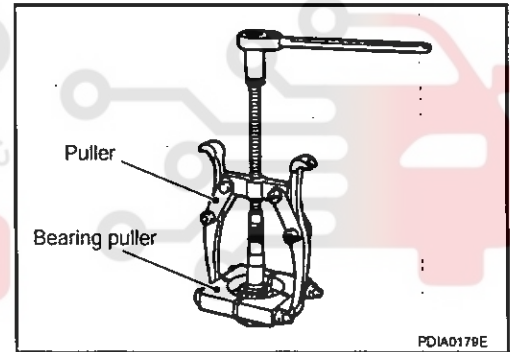

- Using a brass rod, tap pinion front bearing outer race evenly from the 2 cutouts on gear carrier and remove pinion front bearing outer race.

CAUTION:

Be careful not to damage gear carrier.

- Using a brass rod, tap drive pinion adjusting shim evenly from the 2 cutouts on gear carrier and remove drive pinion adjusting shim and pinion rear bearing outer race.

CAUTION:

Be careful not to damage the gear carrier.

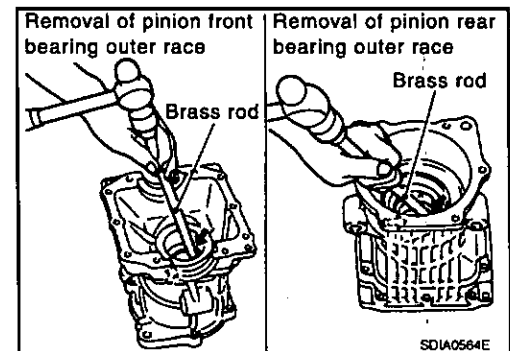

DRIVE PINION

< DISASSEMBLY AND ASSEMBLY >

[REAR FINAL DRIVE: R145]

Assembly

INFOID.000000004905515

1. Install a drive pinion adjusting shim of the same thickness as was installed prior to disassembly. Press pinion rear bearing outer race into gear carrier, using the suitable drift.

CAUTION:

- At first, using a hammer, tap bearing outer race until it becomes flush to gear carrier.
- Never reuse pinion rear bearing outer race.

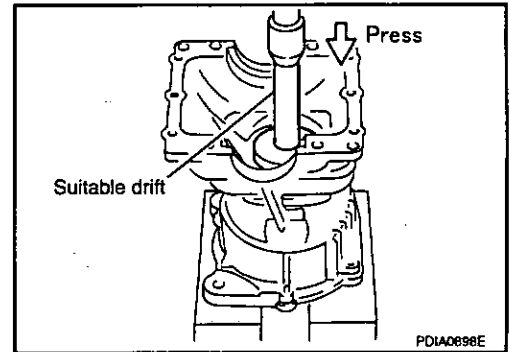

A
B
C

DLN

2. Press pinion front bearing outer race into gear carrier, using the drift (SST: 33230000).

CAUTION:

- At first, using a hammer, tap bearing outer race until it becomes flush to gear carrier.
- Never reuse pinion front bearing outer race.

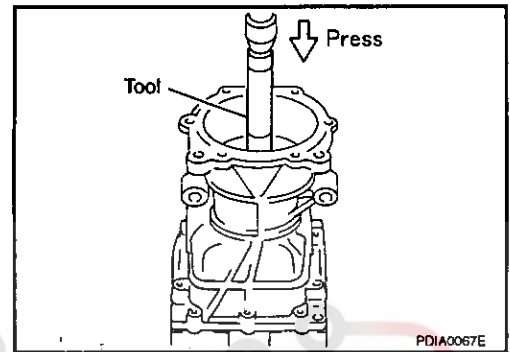

E
F
G

3. Press pinion rear bearing inner race to drive pinion, using the drift (SST: ST23860000).

CAUTION:

- Never reuse pinion rear bearing inner race.

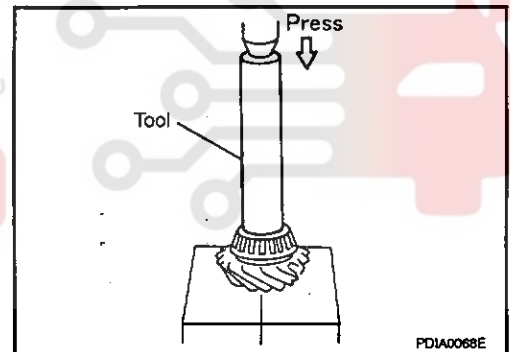

H
I
J

4. After checking and adjusting the tooth contact and backlash of the hypoid gear following the procedure below.

- a. Apply gear oil to the pinion rear bearing, and assemble the drive pinion to the gear carrier.

CAUTION:

- Never assemble a collapsible spacer.

- b. Apply gear oil to pinion front bearing, and assemble pinion front bearing inner race to drive pinion. Using the drifts and stand, press pinion front bearing inner race to drive pinion as far as drive pinion nut can be tightened.

A : Drift (SST: ST23860000)

B : Drift (commercial service tool)

CAUTION:

- Never reuse pinion front bearing inner race.

- c. Temporarily tighten removed drive pinion nut to drive pinion.

NOTE:

- Use removed drive pinion nut only for the preload measurement.

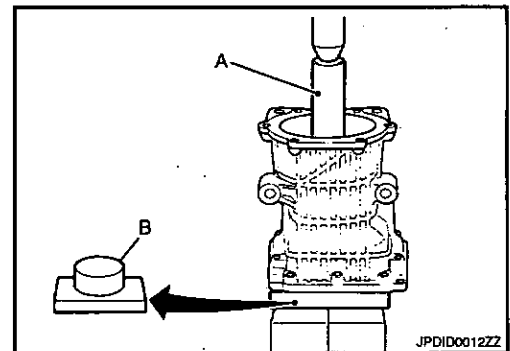

L
M
N
O
P

DRIVE PINION

< DISASSEMBLY AND ASSEMBLY >

[REAR FINAL DRIVE: R145]

d. Fit the drive pinion socket (A) (SST: KV38108500) onto the drive pinion spline. Using the pinion nut wrench (B) (SST: KV38108400), tighten drive pinion nut to the specified preload torque.

C : Preload gauge (SST: ST3127S000)

Standard

Pinion bearing preload : Refer to DLN-149, "Preload Torque".

CAUTION:

Drive pinion nut is tightened with no collapsible spacer. Be careful not to over tighten it. While measuring the preload, tighten it by 5° to 10°.

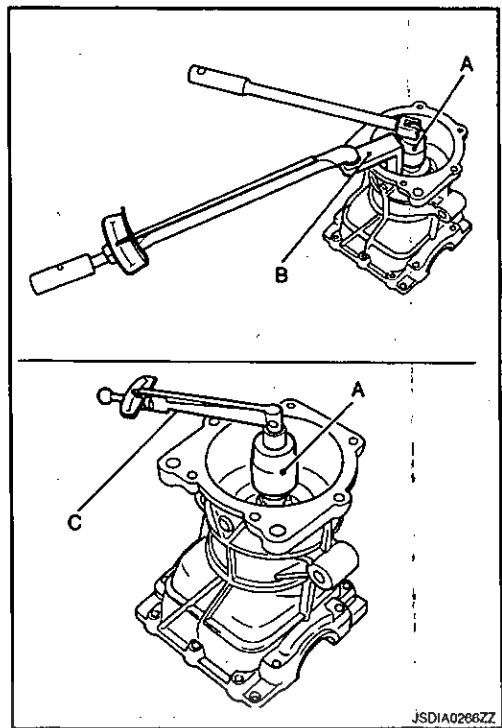

e. Apply gear oil to side bearings, and install new side bearing adjusting shims with the same thickness or re-install the old ones to the same mounting position they were in prior to disassembly. Set the drifts (commercial service tool) to the right and left. Install differential case assembly to gear carrier.

CAUTION:

- The drifts shall be placed on the center of the adjusting shims.
- The pressure shall be as low as possible to install gear carrier assembly to differential assembly. The maximum pressure shall be 10 kN (1 ton, 1.0 Imp ton).
- If adjusting shims are installed by tapping, gear carrier may be damaged. Avoid tapping.

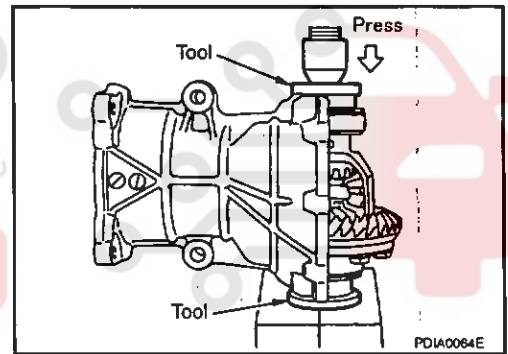

f. Check and adjust the tooth contact. Refer to DLN-144, "Adjustment".

g. Check and adjust the backlash. Refer to DLN-144, "Adjustment".

h. Remove dummy cover set, and remove differential case assembly.

i. Remove drive pinion nut and press drive pinion assembly out of gear carrier.

CAUTION:

Never drop drive pinion assembly.

j. Remove pinion front bearing inner race.

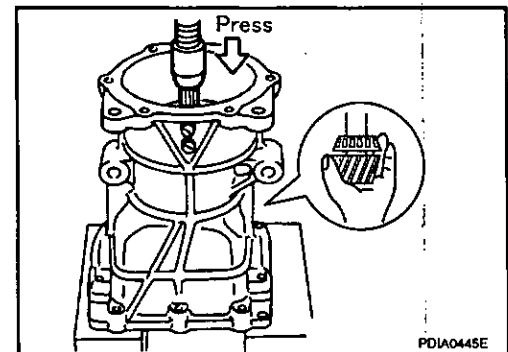

DRIVE PINION

< DISASSEMBLY AND ASSEMBLY >

[REAR FINAL DRIVE: R145]

5. Assemble collapsible spacer to drive pinion.

CAUTION:

- Be careful of the mounting direction of collapsible spacer.
- Never reuse collapsible spacer.

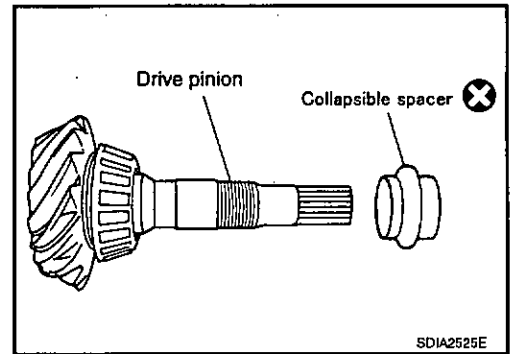

6. Apply gear oil to pinion front bearing, and assemble pinion front bearing inner race to drive pinion. Using the drifts and stand, press pinion front bearing inner race to drive pinion as far as drive pinion nut can be tightened.

A : Drift (SST: ST23860000)

B : Drift (commercial service tool)

CAUTION:

Never reuse pinion front bearing inner race.

7. Apply anti-corrosive oil to the thread and seat of drive pinion nut, and temporarily tighten drive pinion nut to drive pinion.

CAUTION:

Never reuse drive pinion nut.

8. Fit the drive pinion socket (A) (SST: KV38108500) onto the drive pinion spline. Using the pinion nut wrench (B) (SST: KV38108400), adjust the drive pinion nut tightening torque and pinion bearing preload torque.

C : Preload gauge (SST: ST3127S000)

Drive pinion tightening torque : Refer to DLN-138, "Exploded View".

Standard

Pinion bearing preload : Refer to DLN-149, "Preload Torque".

CAUTION:

- Adjust the lower limit of the drive pinion nut tightening torque first.
- If the preload torque exceeds the specified value, replace collapsible spacer and tighten it again to adjust. Never loosen drive pinion nut to adjust the preload torque.
- After adjustment, rotate drive pinion back and forth 2 to 3 times to check for unusual noise, rotation malfunction, and other malfunctions.

9. Install differential case assembly. Refer to DLN-134, "Assembly".

CAUTION:

Never install rear cover.

10. Install dummy cover set, and check drive gear runout, tooth contact, and backlash. Refer to DLN-144, "Adjustment".

11. Remove dummy cover set, then install rear cover, and side oil seal. Refer to DLN-134, "Assembly".

12. Check total preload torque. Refer to DLN-144, "Adjustment".

13. Install electric controlled coupling assembly. Refer to DLN-128, "Assembly".

14. Check companion flange runout. Refer to DLN-130, "Adjustment".

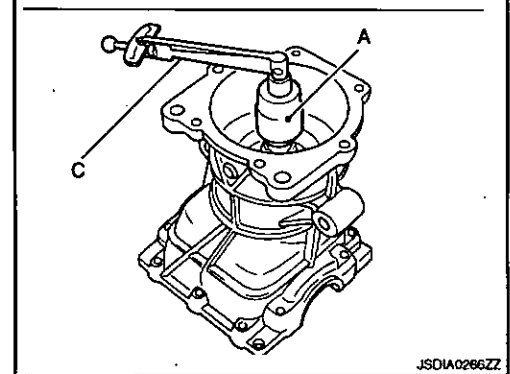
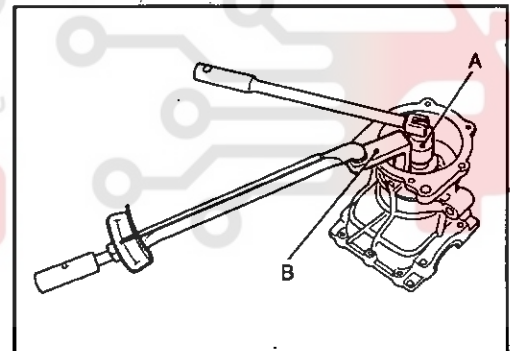
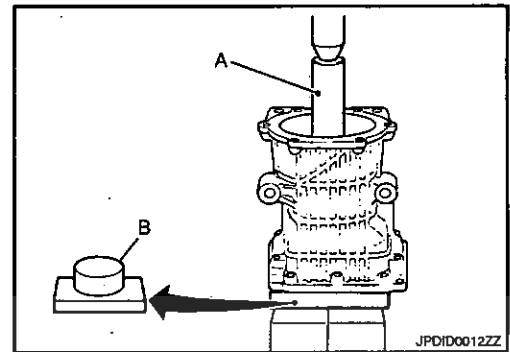

A
B
C
DLN
E
F
G
H
I
J
K
L
M
N
O
P

DRIVE PINION

< DISASSEMBLY AND ASSEMBLY >

[REAR FINAL DRIVE: R145]

Adjustment

INFOID:000000004905516

TOTAL PRELOAD TORQUE

1. Remove electric controlled coupling assembly. Refer to DLN-128, "Disassembly".
2. Rotate drive pinion back and forth 2 to 3 times to check for unusual noise and rotation malfunction.
3. Rotate drive pinion at least 20 times to check for smooth operation of the bearing.
4. Fit drive pinion socket onto drive pinion spline. Measure the total preload, using the preload gauge (A) (SST: 3127S000) and drive pinion socket (B) (SST: KV38108500).

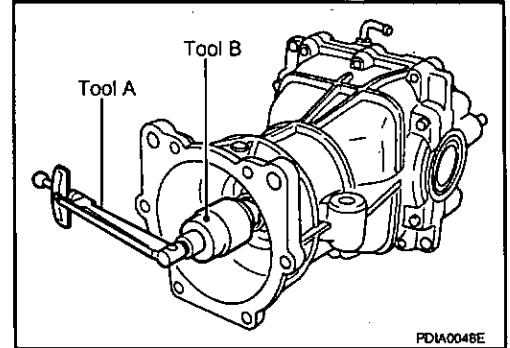

Standard

Total preload torque : Refer to DLN-149, "Preload Torque".

NOTE:

Total preload torque = Pinion bearing torque + Side bearing torque

- If measured value is out of the specification, disassemble it to check and adjust each part. Adjust the pinion bearing preload and side bearing preload. Adjust the pinion bearing preload first, then adjust the side bearing preload.

When the preload torque is large

On pinion bearings: Replace the collapsible spacer.

On side bearings: Use thinner side bearing adjusting shims.

When the preload is small

On pinion bearings: Tighten the drive pinion nut.

On side bearings: Use thicker side bearing adjusting shims.

DRIVE GEAR RUNOUT

1. Remove rear cover. Refer to DLN-133, "Disassembly".
2. Following the procedure below, install a dummy cover set (SST: KV389L0010) to gear carrier.
 - a. Set dummy cover shims to the right and left side bearing adjusting shims.
 - b. Temporarily tighten dummy cover to gear carrier.
 - c. Position dummy cover spacers to dummy cover.
 - d. Tighten rear cover mounting bolts to the specified torque. Refer to DLN-138, "Exploded View".
 - e. Tighten dummy cover spacer mounting bolts evenly to the specified torque.

 : 5.9 N·m (0.6 kg-m, 52 in-lb)

3. Fit a dial indicator to the drive gear back face.
4. Rotate the drive gear to measure runout.

Limit

Drive gear back face runout : Refer to DLN-149, "Drive Gear Runout".

- If the runout is outside of the repair limit, check drive gear assembly condition; foreign material may be caught between drive gear and differential case, or differential case or drive gear may be deformed, etc.

CAUTION:

Replace drive gear and drive pinion as a set.

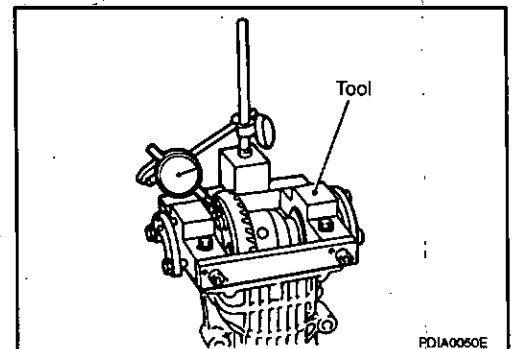

DRIVE PINION

[REAR FINAL DRIVE: R145]

< DISASSEMBLY AND ASSEMBLY >

TOOTH CONTACT

1. Remove rear cover. Refer to DLN-133, "Disassembly".
2. Following the procedure below, install a dummy cover set (SST: KV389L0010) to gear carrier.
 - a. Set dummy cover shims to the right and left side bearing adjusting shims.
 - b. Temporarily tighten dummy cover to gear carrier.
 - c. Position dummy cover spacers to dummy cover.
 - d. Tighten rear cover mounting bolts to the specified torque. Refer to DLN-138, "Exploded View".
 - e. Tighten dummy cover spacer mounting bolts evenly to the specified torque.

 : 5.9 N·m (0.6 kg-m, 52 in-lb)

3. Apply red lead to drive gear.

CAUTION:

Apply red lead to both the faces of 3 to 4 gears at 4 locations evenly spaced on drive gear.

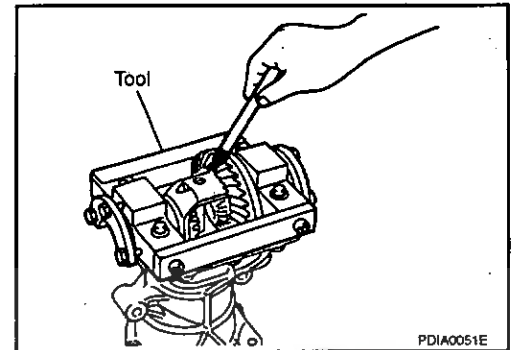

4. Rotate drive gear back and forth several times, check drive pinion gear to drive gear tooth contact.

CAUTION:

Check tooth contact on drive side and reverse side.

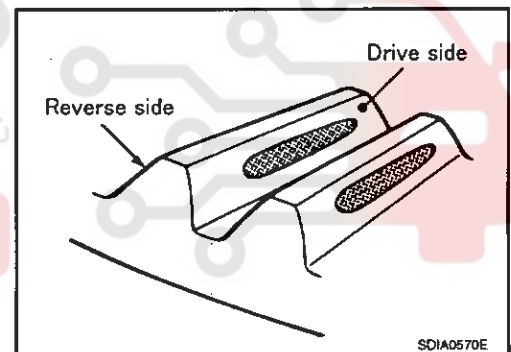

A

B

C

DLN

E

F

G

H

I

J

K

L

M

N

O

P

DRIVE PINION

< DISASSEMBLY AND ASSEMBLY >

[REAR FINAL DRIVE: R145]

Tooth Contact Judgment Guide

Tooth contact condition		Drive pinion adjusting shim selection value [mm (In)]	Adjustment (Yes/No)	Possible cause
Drive side	Back side			
Heel side 	Toe side 	↑ Thicker	Yes	Occurrence of noise and scoring sound in all speed ranges.
				+0.09 (+0.0035)
		↓ Thinner	No	-
		+0.03 (+0.0012)	Yes	Occurrence of noise at constant speed and decreasing speed.
		0		
		-0.03 (-0.0012)	Yes	Occurrence of noise and scoring sound in all speed ranges.
		-0.06 (-0.0024)		
		-0.09 (-0.0035)		

5. If tooth contact is improperly adjusted, follow the procedure below to adjust the pinion height (dimension X).

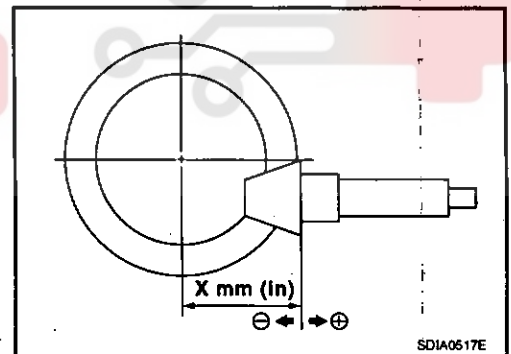

- If the tooth contact is near the face (face contact), or near the heel (heel contact), thicken drive pinion gear adjusting shim to move drive pinion closer to drive gear.

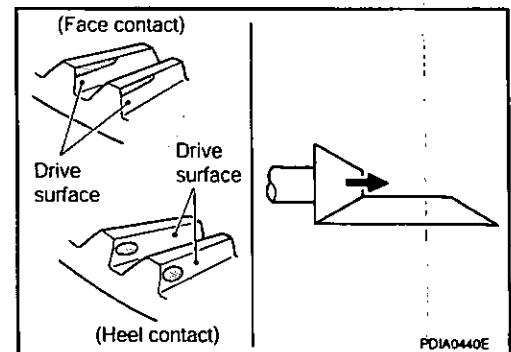

DRIVE PINION

< DISASSEMBLY AND ASSEMBLY >

[REAR FINAL DRIVE: R145]

- If the tooth contact is near the flank (flank contact), or near the toe (toe contact), thin drive pinion gear adjusting shim to move drive pinion farther from drive gear.

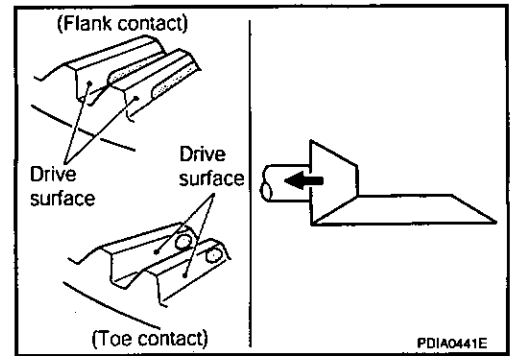

A
B
C

DLN

BACKLASH

1. Remove rear cover. Refer to DLN-133, "Disassembly".
2. Following the procedure below, install a dummy cover set (SST: KV389L0010) to gear carrier.
 - a. Set dummy cover shims to the right and left side bearing adjusting shims.
 - b. Temporarily tighten dummy cover to gear carrier.
 - c. Position dummy cover spacers to dummy cover.
 - d. Tighten rear cover mounting bolts to the specified torque. Refer to DLN-138, "Exploded View".
 - e. Tighten dummy cover spacer mounting bolts evenly to the specified torque.

E

F

G

: 5.9 N·m (0.6 kg-m, 52 in-lb)

3. Fit a dial indicator to the drive gear face to measure the backlash.

Standard Backlash

: Refer to DLN-149, "Backlash".

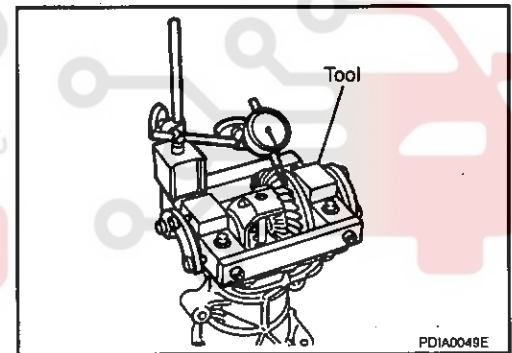

H

I

J

- If the backlash is outside of the specified value, change the thickness of side bearing adjusting shims.

When the backlash is large:

Make drive gear back adjusting shims thicker, and drive gear front adjusting shims thinner.

When the backlash is small:

Make drive gear back adjusting shims thinner, and drive gear front adjusting shims thicker.

K

L

M

Inspection After Disassembly

INFOID:000000004905517

Clean up the disassembled parts. Then, inspect if the parts are worn or damaged. If so, follow the measures below.

N

Content	Conditions and Measures
Hypoid gear	<ul style="list-style-type: none"> • If the gear teeth do not mesh or line-up correctly, determine the cause and adjust or replace as necessary. • If the gears are worn, cracked, damaged, pitted or chipped (by friction) noticeably, replace with new drive gear and drive pinion as a set.
Bearing	If any chipped (by friction), pitted, worn, rusted or scratched mark, or unusual noise from the bearing is observed, replace as a bearing assembly (as a new set).
Side gear and Pinion mate gear	<ul style="list-style-type: none"> • If any cracks or damage on the surface of the tooth is found, replace. • If any worn or chipped mark on the contact sides of the thrust washer is found, replace.
Side gear thrust washer and pinion mate thrust washer	If it is chipped (by friction), damaged, or unusually worn, replace.

O

P

DRIVE PINION

< DISASSEMBLY AND ASSEMBLY >

[REAR FINAL DRIVE: R145]

Content	Conditions and Measures
Differential case	If any wear or crack on the contact sides of the differential case is found, replace.
Companion flange	If any chipped mark (about 0.1 mm, 0.004 in) or other damage on the contact sides of the lips of the companion flange is found, replace.

دیجیتال خودرو

شرکت دیجیتال خودرو سامانه (مسئولیت محدود)

اولین سامانه دیجیتال تعمیرکاران خودرو در ایران

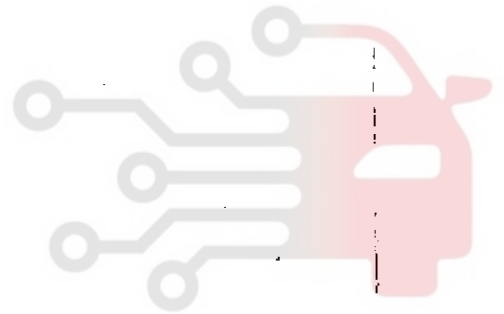

SERVICE DATA AND SPECIFICATIONS (SDS)

< SERVICE DATA AND SPECIFICATIONS (SDS)

[REAR FINAL DRIVE: R145]

SERVICE DATA AND SPECIFICATIONS (SDS)

SERVICE DATA AND SPECIFICATIONS (SDS)

General Specification

INFOID:000000004905518

Applied model	4WD		
	MR20DE		M9R
	M/T	CVT	MT
Final drive model	R145		
Gear ratio	2.466		
Number of teeth (Drive gear/Drive pinion)	37/15		
Oil capacity (Approx.)	ℓ (Imp pt)	0.55 (1)	
Number of pinion gears	2		
Drive pinion adjustment spacer type	Collapsible		

Drive Gear Runout

INFOID:000000004905519

Unit: mm (in)

Item	Limit
Drive gear back face runout	0.05 (0.0020)

Differential Side Gear Clearance

INFOID:000000004905520

Unit: mm (in)

Item	Standard
Side gear backlash (Clearance between side gear and differential case)	0.2 (0.008) or less (Each gear should rotate smoothly without excessive resistance during differential motion.)

Preload Torque

INFOID:000000004905521

Unit: N·m (kg·m, in·lb)

Item	Standard
Pinion bearing (P1)	0.69 – 1.18 (0.07 – 0.12, 7 – 10)
Side bearing (P2)	0.64 – 0.98 (0.07 – 0.09, 6 – 8)
Side bearing to pinion bearing (Total preload) (Total preload = P1 + P2)	1.33 – 2.16 (0.14 – 0.22, 12 – 19)

Backlash

INFOID:000000004905522

Unit: mm (in)

Item	Standard
Drive gear to drive pinion gear	0.10 – 0.15 (0.0039 – 0.0059)

Companion Flange Runout

INFOID:000000004905523

Unit: mm (in)

Item	Limit
Companion flange face	0.13 (0.0051)
Inner side of the companion flange	0.19 (0.0075)