

BCM X 4

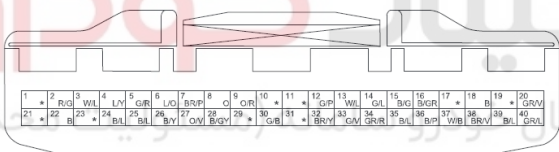

AT gearshift panel

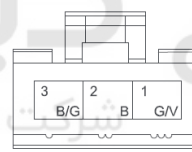

Hazard warning lamp switch

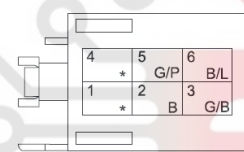

اولین سامانه دیجیتال تعمیرکاران خودرو در ایران

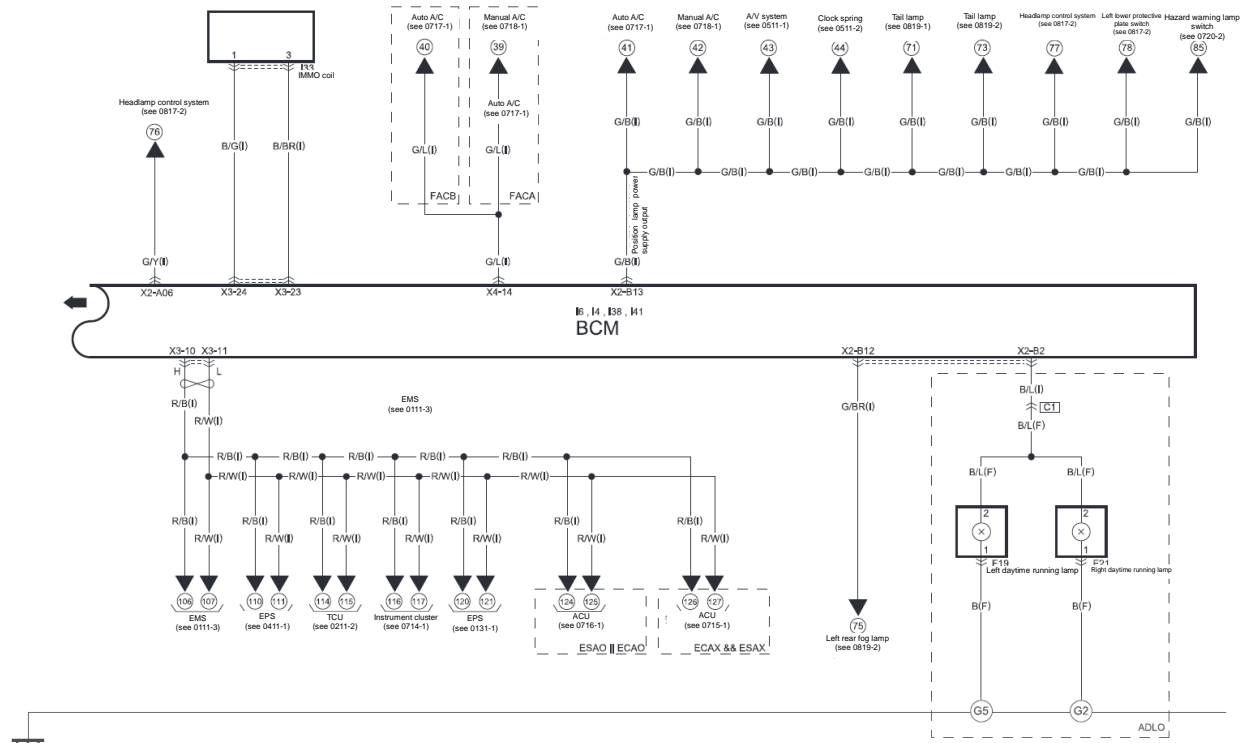

BCM X 3

1	2	3	4	5	6	7	8	9	10	11	12
*	*	R/G	G/P	R/L	G/V	*	*	*	R/B	R/W	*
13	14	15	16	17	18	19	20	21	22	23	24
P/W	P/B	G/W	G/B	*	*	*	*	B/G	*	B/BR	B/G

IMMO coil

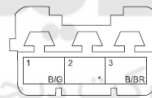

Left daytime running lamp

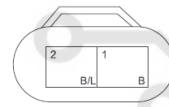

Right daytime running lamp

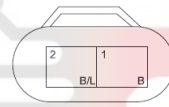

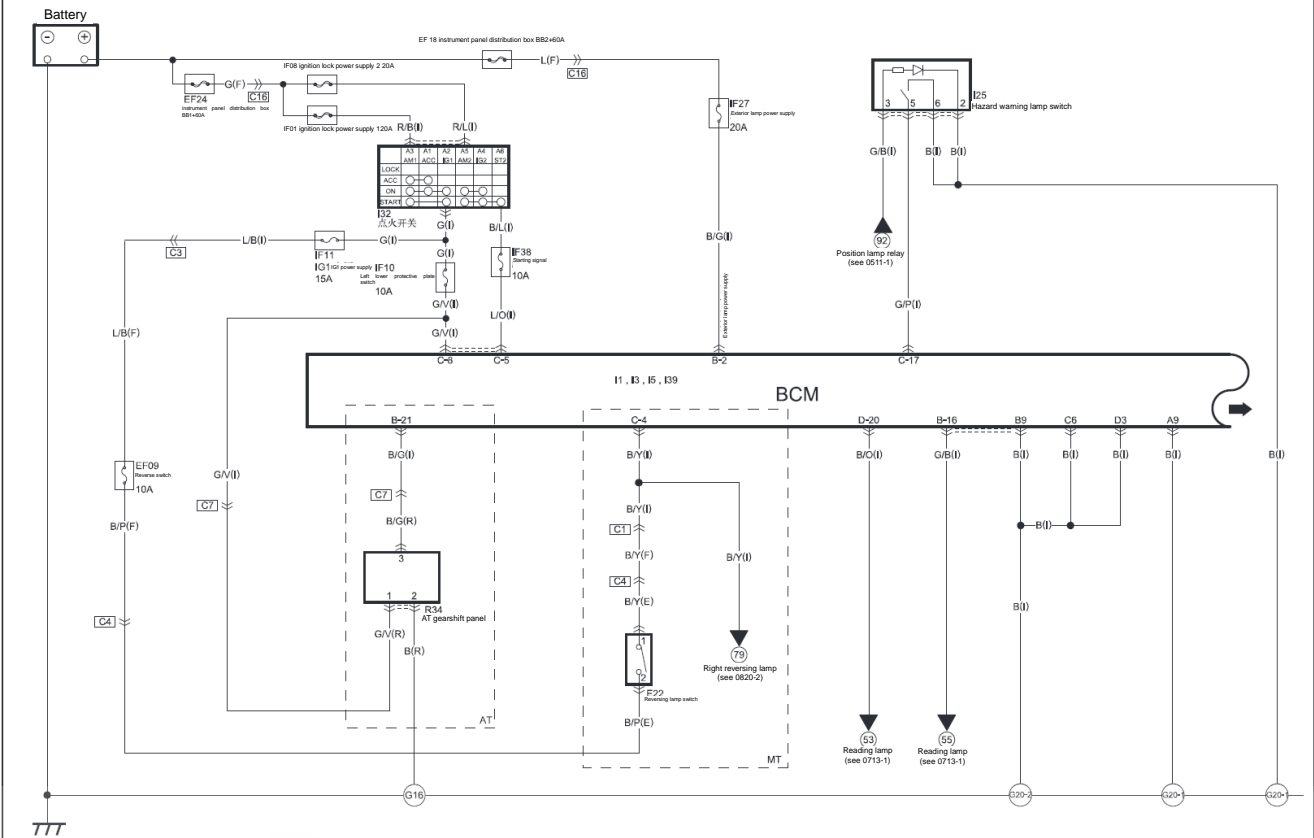

<p>BCM C</p> <table border="1"> <tr><td>1</td><td>2</td><td>3</td><td>4</td><td>5</td><td>6</td><td>7</td><td>8</td><td>9</td><td>10</td><td>11</td><td>12</td><td>13</td><td>14</td><td>15</td><td>16</td><td>17</td><td>18</td><td>19</td><td>20</td></tr> <tr><td>21</td><td>22</td><td>23</td><td>24</td><td>25</td><td>26</td><td>27</td><td>28</td><td>29</td><td>30</td><td>31</td><td>32</td><td>33</td><td>34</td><td>35</td><td>36</td><td>37</td><td>38</td><td>39</td><td>40</td></tr> <tr><td>REG</td><td>Brk</td><td>CL</td><td>GR</td><td>BL</td><td>GRN</td><td>GRN</td><td>GRN</td><td>GRN</td><td>GRN</td><td>GRN</td><td>GRN</td><td>GRN</td><td>GRN</td><td>GRN</td><td>GRN</td><td>GRN</td><td>GRN</td><td>GRN</td><td>GRN</td></tr> </table>	1	2	3	4	5	6	7	8	9	10	11	12	13	14	15	16	17	18	19	20	21	22	23	24	25	26	27	28	29	30	31	32	33	34	35	36	37	38	39	40	REG	Brk	CL	GR	BL	GRN	GRN	GRN	GRN	GRN	GRN	GRN	GRN	GRN	GRN	GRN	GRN	GRN	GRN	GRN	<p>AT gearshift panel</p> <table border="1"> <tr><td>3</td><td>2</td><td>1</td></tr> <tr><td>B/G</td><td>B</td><td>G/V</td></tr> </table>	3	2	1	B/G	B	G/V	<p>Reversing lamp switch</p> <table border="1"> <tr><td>1</td><td>2</td></tr> <tr><td>B/Y</td><td>B/P</td></tr> </table>	1	2	B/Y	B/P	<p>Hazard warning lamp switch</p> <table border="1"> <tr><td>4</td><td>5</td><td>6</td></tr> <tr><td>*</td><td>G/P</td><td>B/L</td></tr> <tr><td>1</td><td>2</td><td>3</td></tr> <tr><td>*</td><td>B</td><td>G/B</td></tr> </table>	4	5	6	*	G/P	B/L	1	2	3	*	B	G/B
1	2	3	4	5	6	7	8	9	10	11	12	13	14	15	16	17	18	19	20																																																																		
21	22	23	24	25	26	27	28	29	30	31	32	33	34	35	36	37	38	39	40																																																																		
REG	Brk	CL	GR	BL	GRN	GRN	GRN	GRN	GRN	GRN	GRN	GRN	GRN	GRN	GRN	GRN	GRN	GRN	GRN																																																																		
3	2	1																																																																																			
B/G	B	G/V																																																																																			
1	2																																																																																				
B/Y	B/P																																																																																				
4	5	6																																																																																			
*	G/P	B/L																																																																																			
1	2	3																																																																																			
*	B	G/B																																																																																			

