

Transmission control system (AT)

B-2a

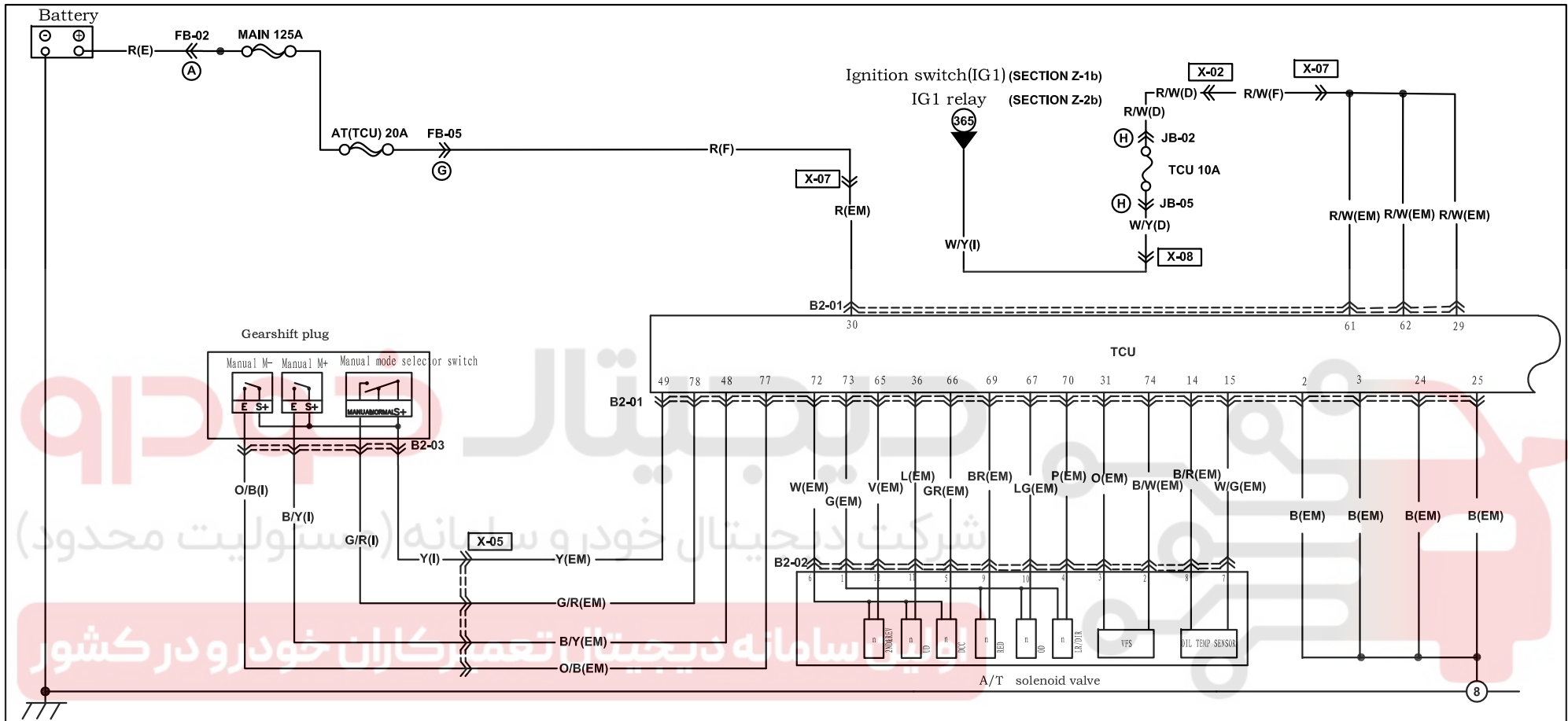

B2-01 TCU(EM)

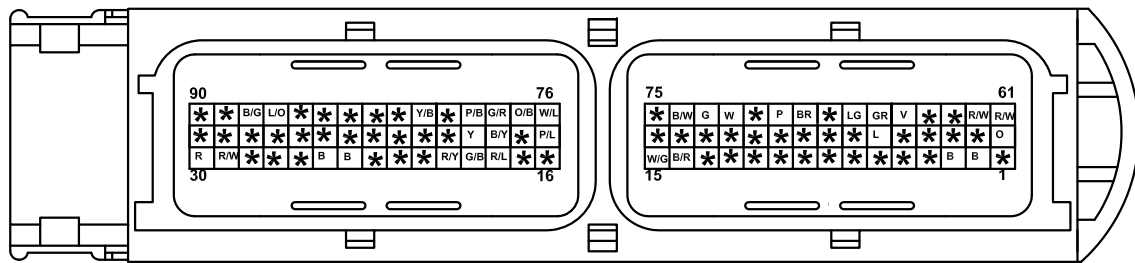

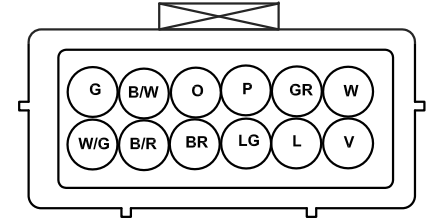

B2-02 A/T solenoid valve (EM)



B2-03 Gearshift plug (I)

G	L/G			Y	B/Y	A
H	LG/B	*	G/R	*	O/B	B

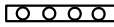
Harness mark:  (F)  (E)  (D)  (R)

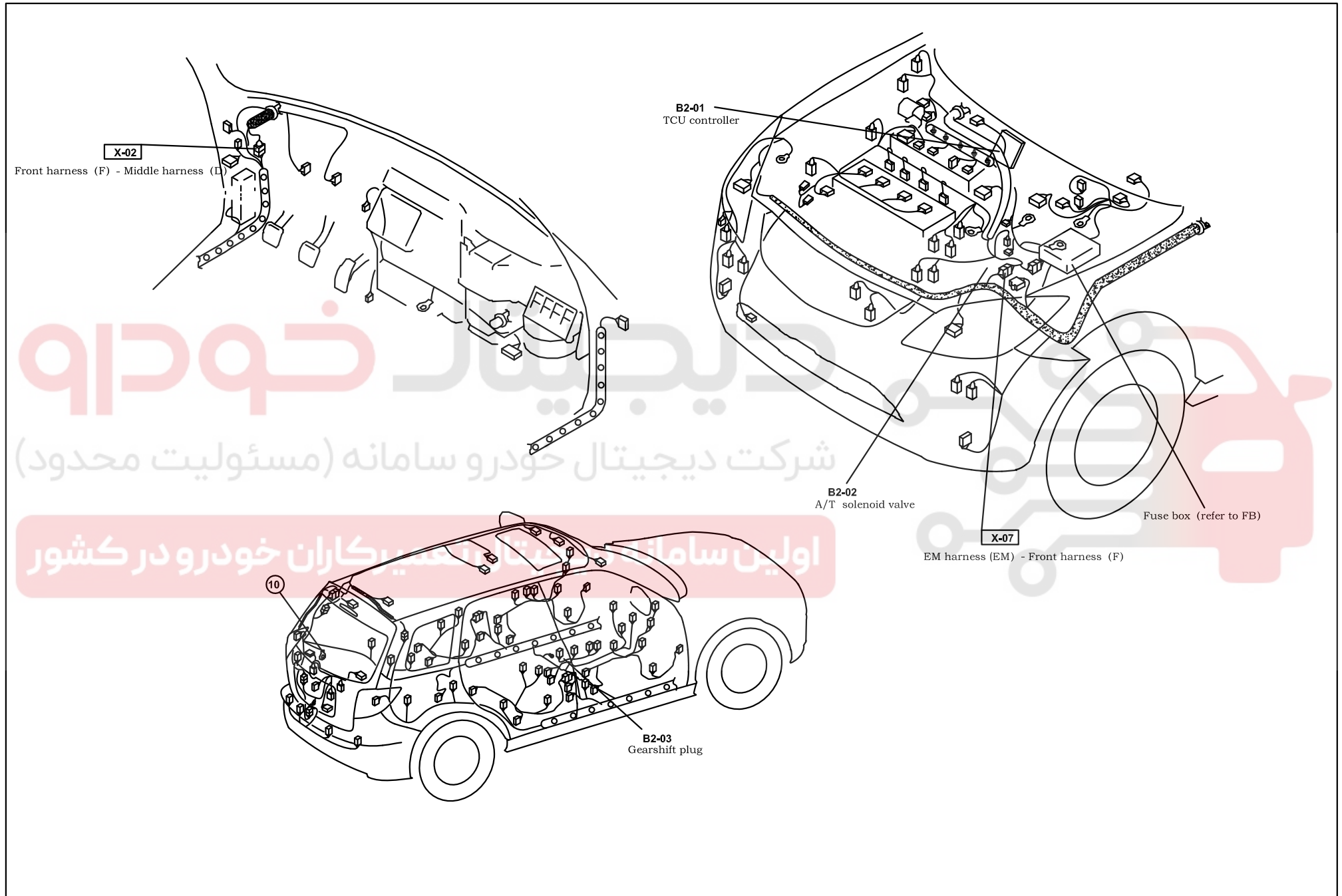

Transmission control system (AT)

B-2b

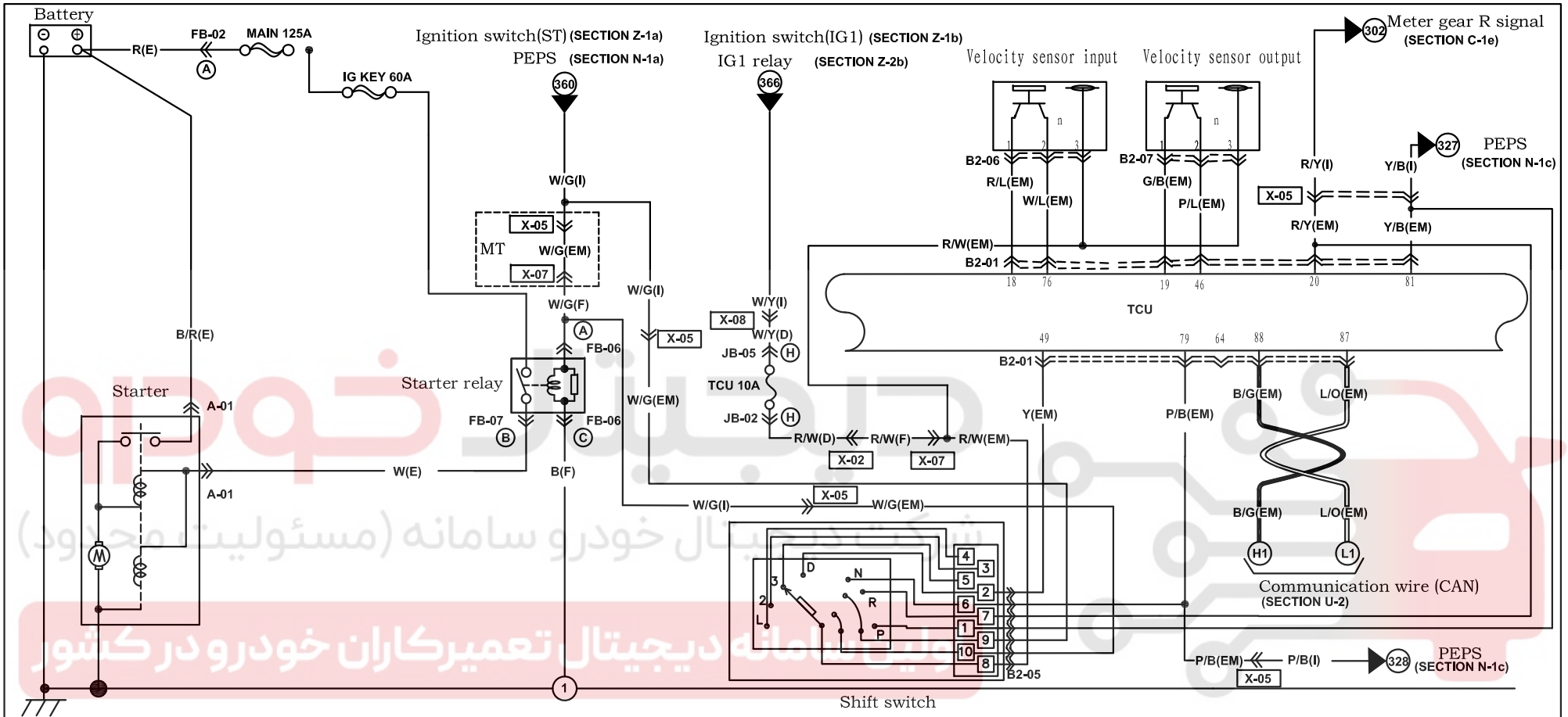

B2-01 TCU(EM)

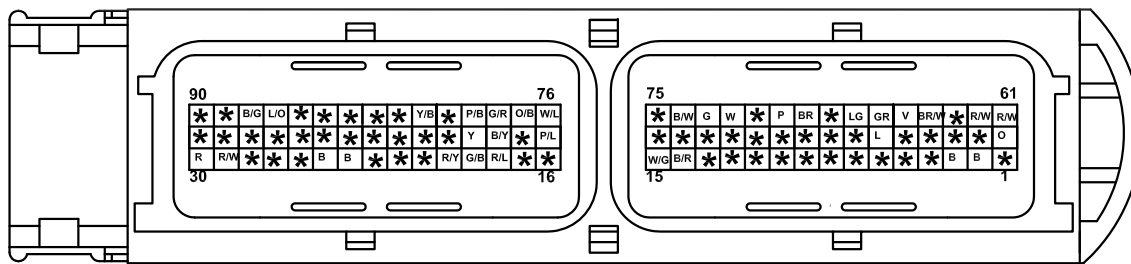

B2-05 Shift switch (EM)

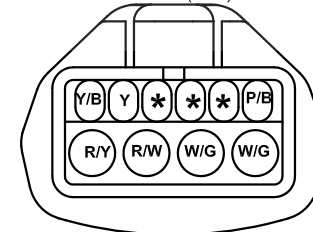

B2-06 Velocity sensor input (EM)

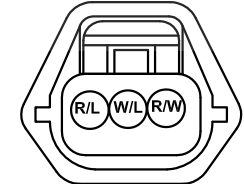

B2-07 Velocity sensor output (EM)

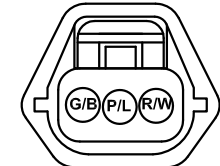

Harness mark:  (F)  (E)  (D)  (R)

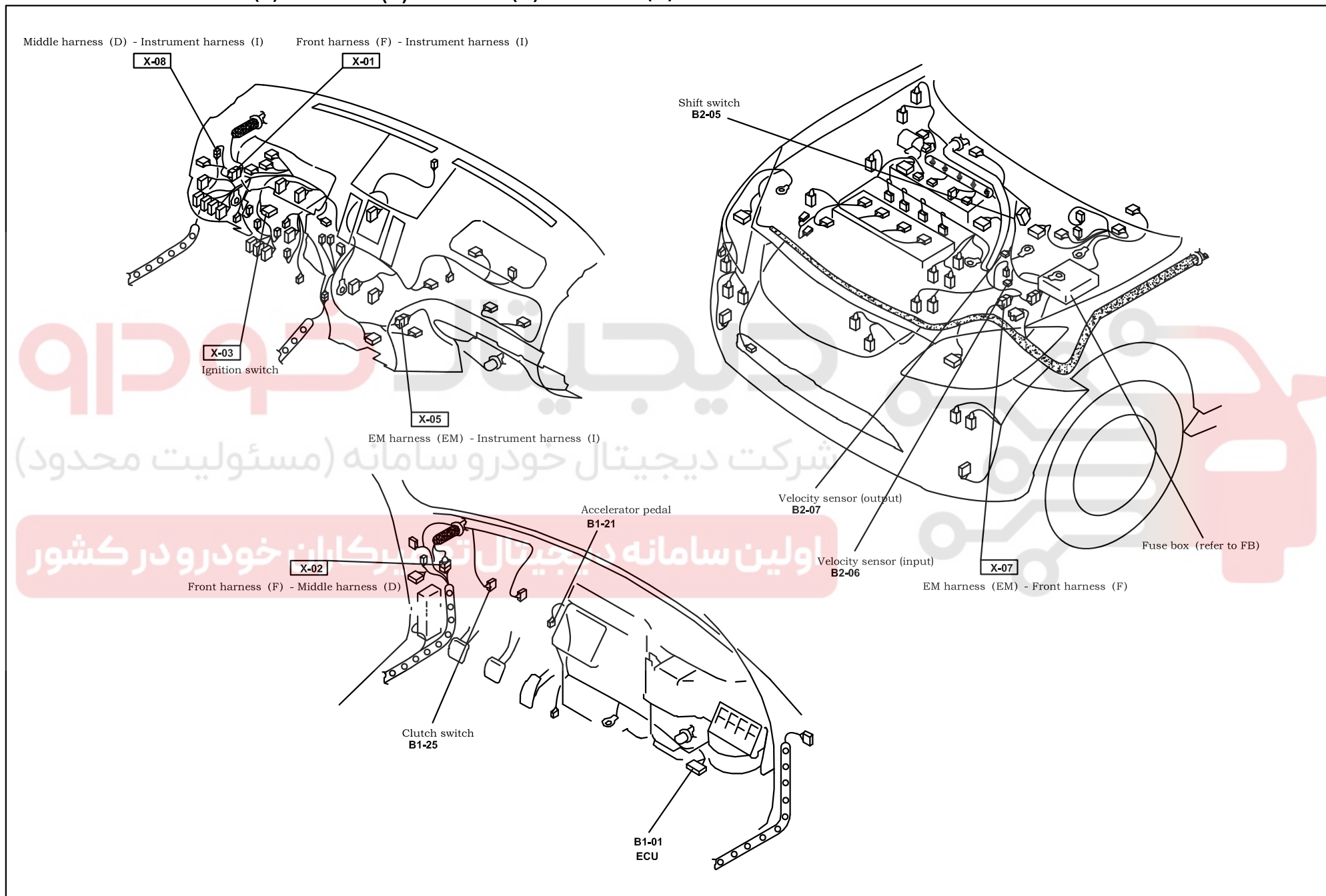

دیجیتال خودرو

شرکت دیجیتال خودرو سامانه (مسئولیت محدود)

اولین سامانه دیجیتال برای مکانیکان خودرو در کشور