





Harness mark:  (F)  (E)  (D)  (R)



Harness mark:  (F)  (E)  (D)  (R)

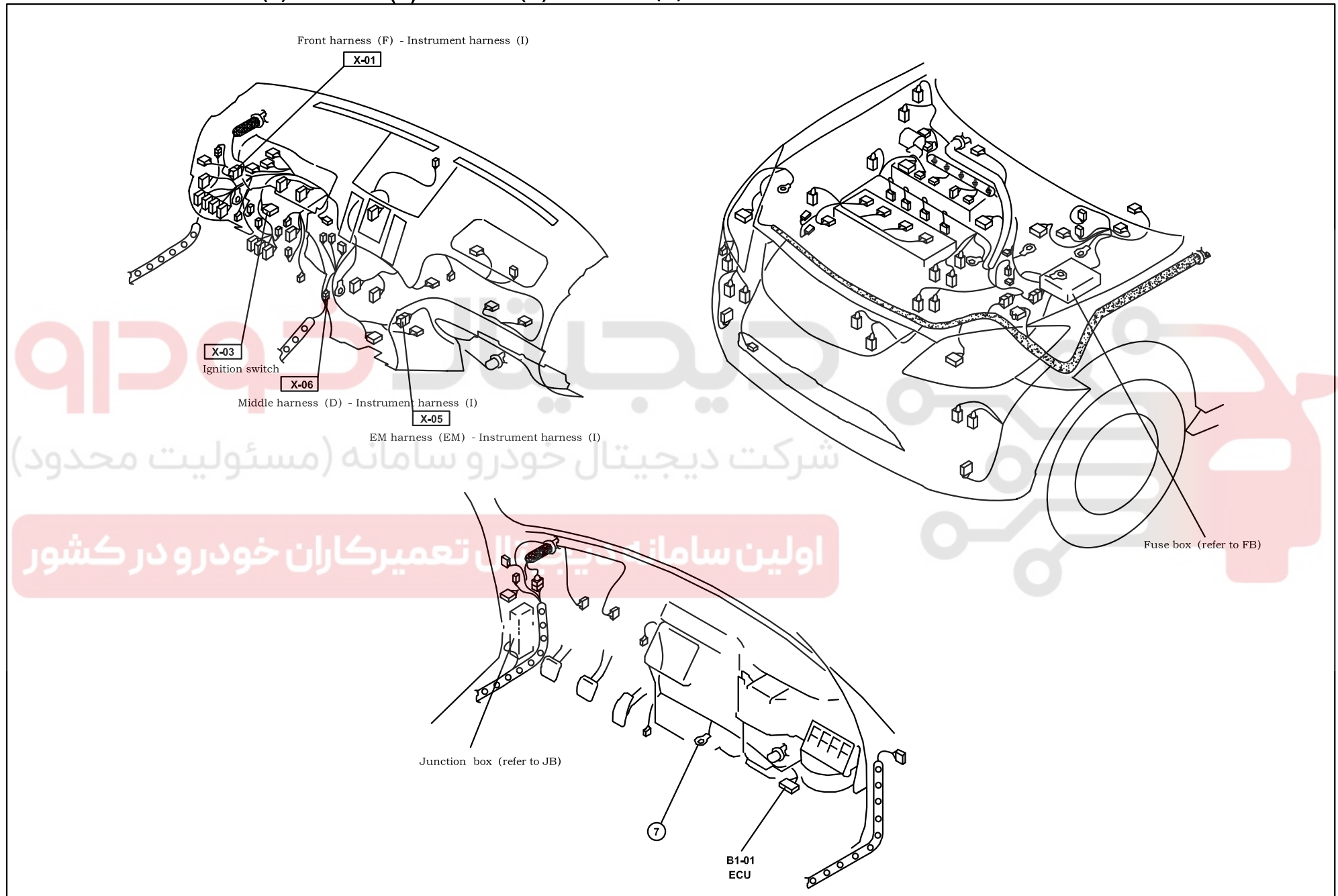
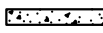

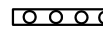
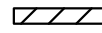
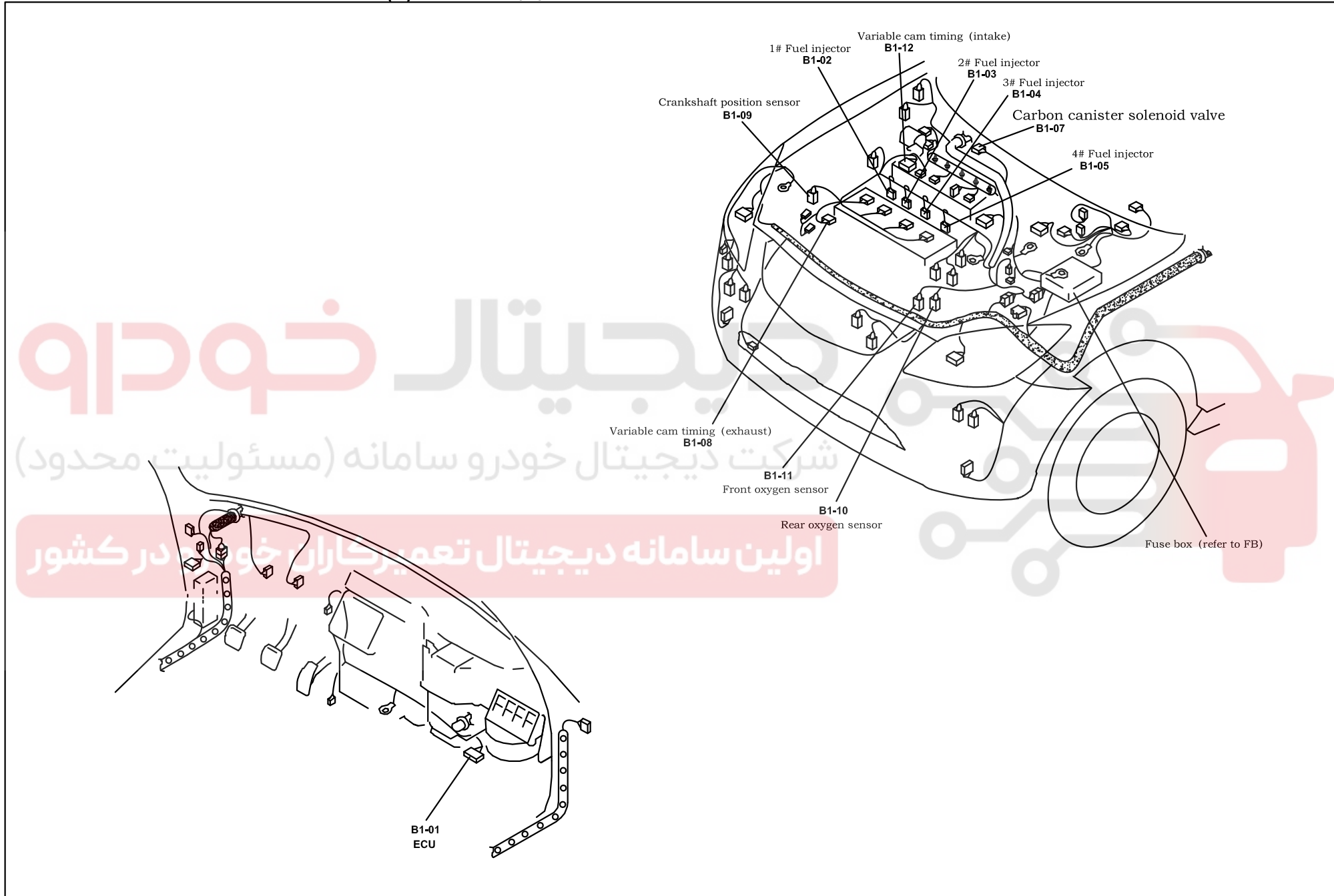
دیجیتال خودرو

شرکت دیجیتال خودرو سامانه (مسئولیت محدود)

اولین سامانه دیجیتال تعمیرکاران خودرو در کشور

Engine control system (484Q)

B-1c

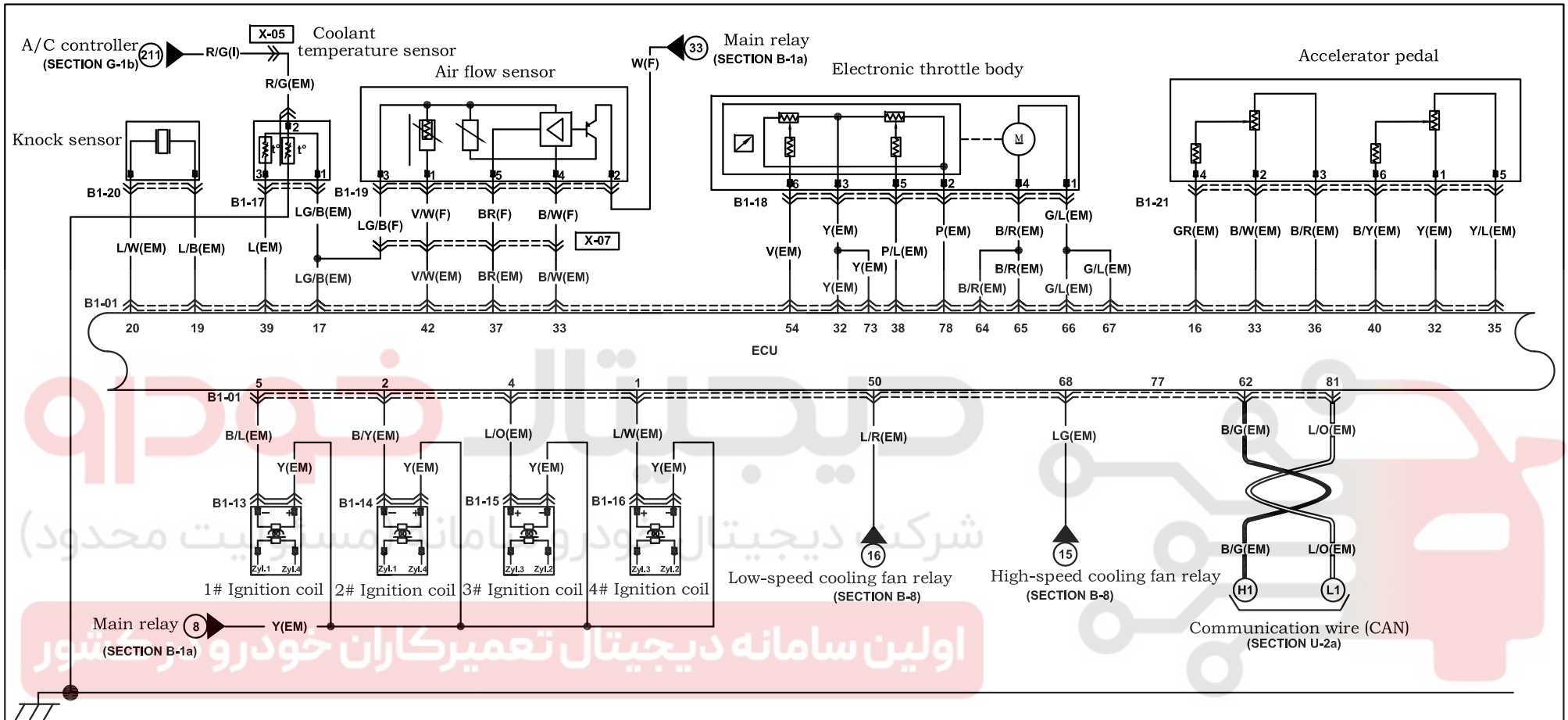



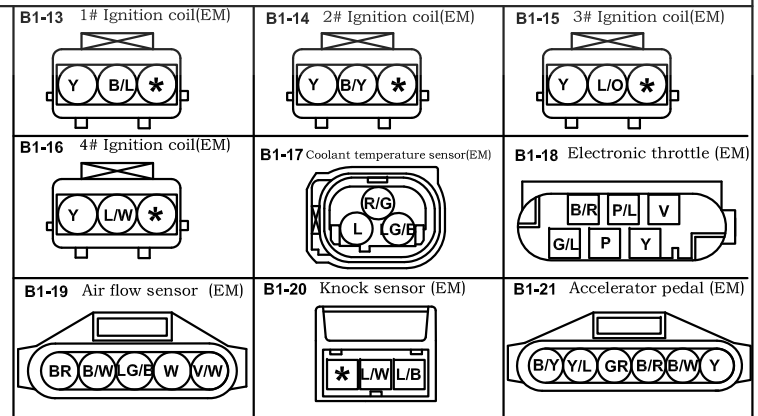

B1-01 ECU(EM)

<> AT Model & Start-stop model

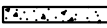

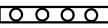
63	W	B/R	B/R	G/L	G/L	LG	BR/Y	W/R	G/B	Y/G	Y	Y/L	G	*	&Y/R	P	W/L	B	L/O	81
	W	W	B/O	R/L	Y/G	*	L/R	B	&B/R	B	V	O	&W	LG/R	B/L	&O/L	&B/W	B	B/G	62
44																				
25	*	R/G	R/B	G/W	Y/L	&Q/W	*	Y	B/W	Y/G	Y/L	B/R	BR	P/L	L	B/Y	&G/R	V/W	&P/G	43
	R/W	R/Y	GR/L	*	*	&GR/R	G/W	W/B	W/G	W/R	GR	LG/B	R/W	L/B	L/W	R/G	&V/G	*	*	24
6																				

Harness mark:  (F)  (E)  (D)  (R)

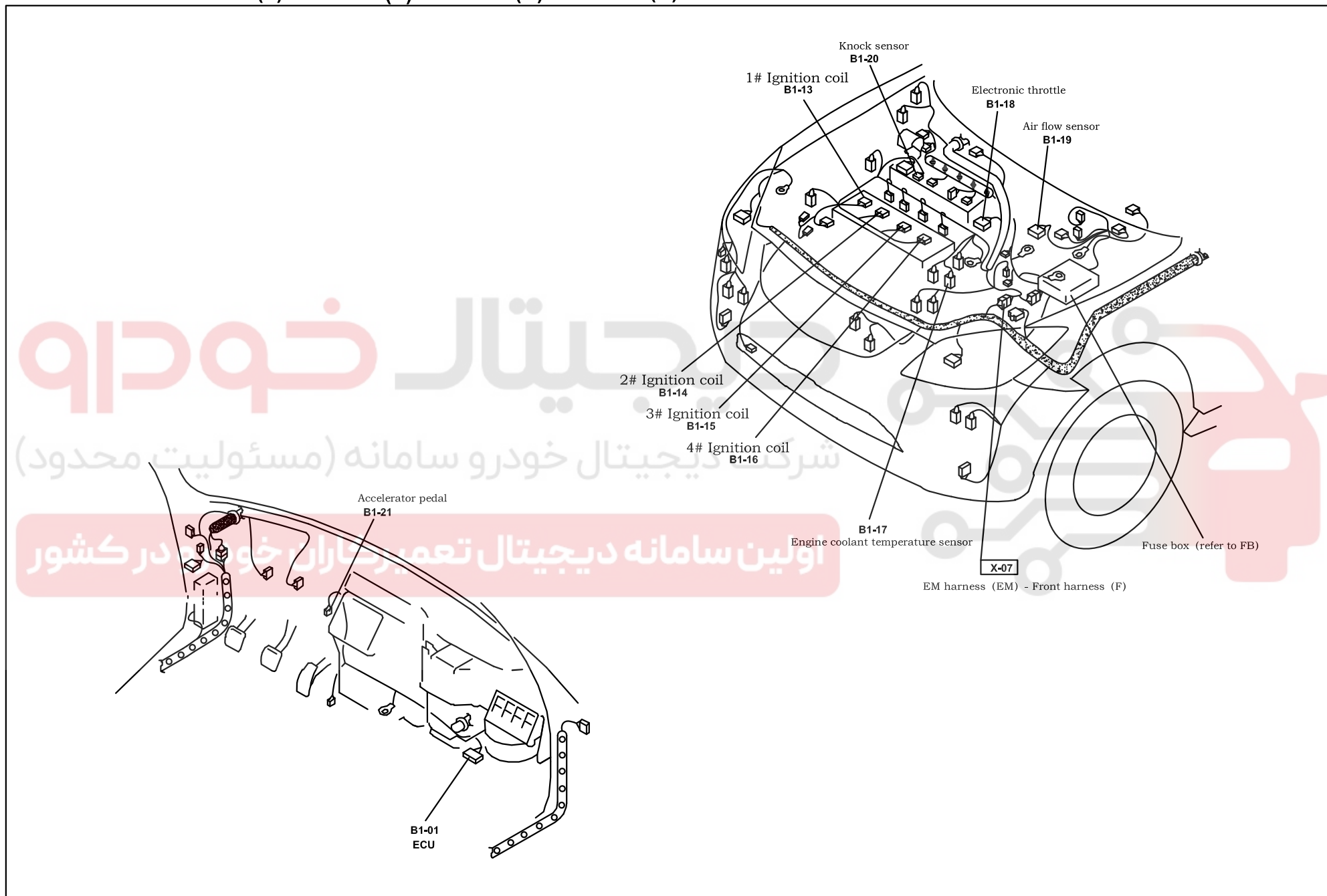

EM harness (EM) - Front harness (F)

Engine control system (484Q)

B-1d

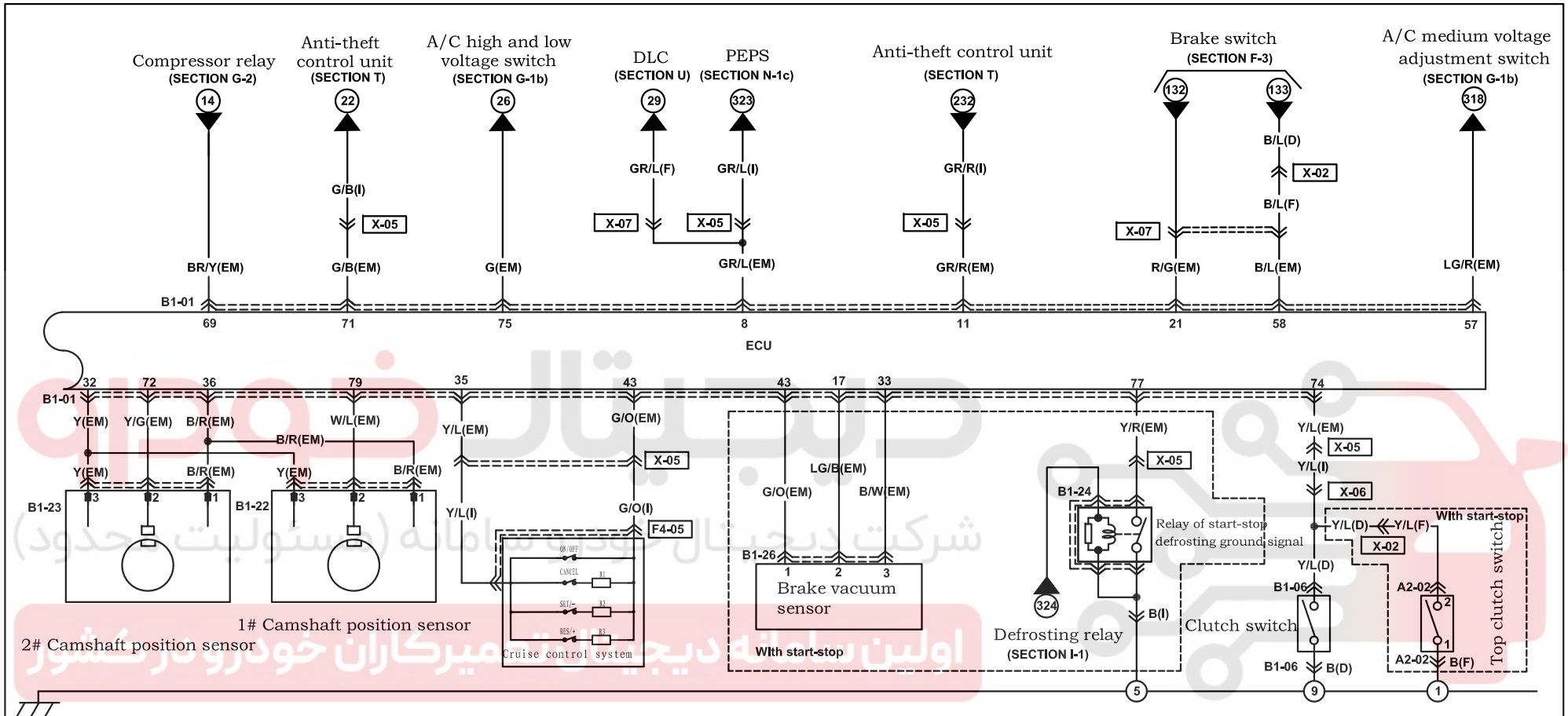

B1-01 ECU(EM)

< > AT Model & Start-stop model

63	W	B/R	B/R	G/L	G/L	LG	BR/Y	W/R	G/B	Y/G	Y	Y/L	G	*	&Y/R	P	W/L	B	L/O	81
	W	W	B/O	R/L	Y/G	*	L/R	B	&B/R	B	V	O	&W	LG/R	B/L	&O/L	&B/W	B	B/G	62
44																				
25	*	R/G	R/B	G/W	Y/L	&Q/W	*	Y	B/W	Y/G	Y/L	B/R	BR	P/L	L	B/Y	&G/R	V/W	&P/G	43
	R/W	R/Y	GR/L	*	*	&G/R	G/W	W/B	W/G	W/R	GR	LG/B	R/W	L/B	L/W	R/G	&V/G	*	*	24
6																				

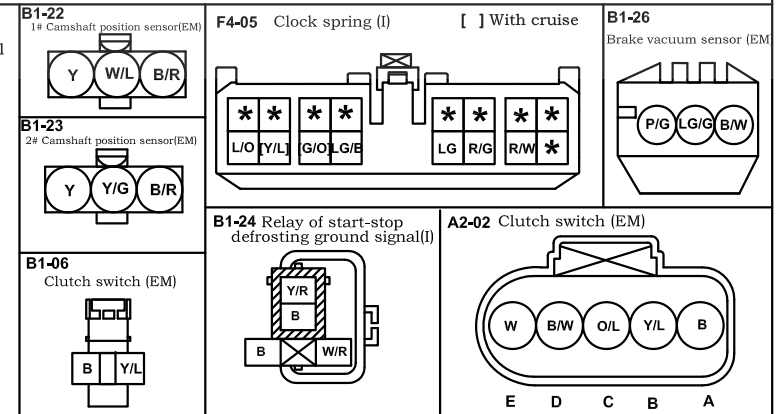
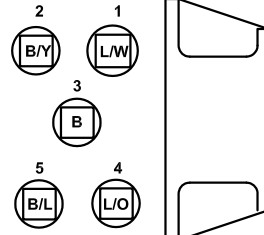

Harness mark:  (F)  (E)  (D)  (R)

