

allocation of BFH1 fuses

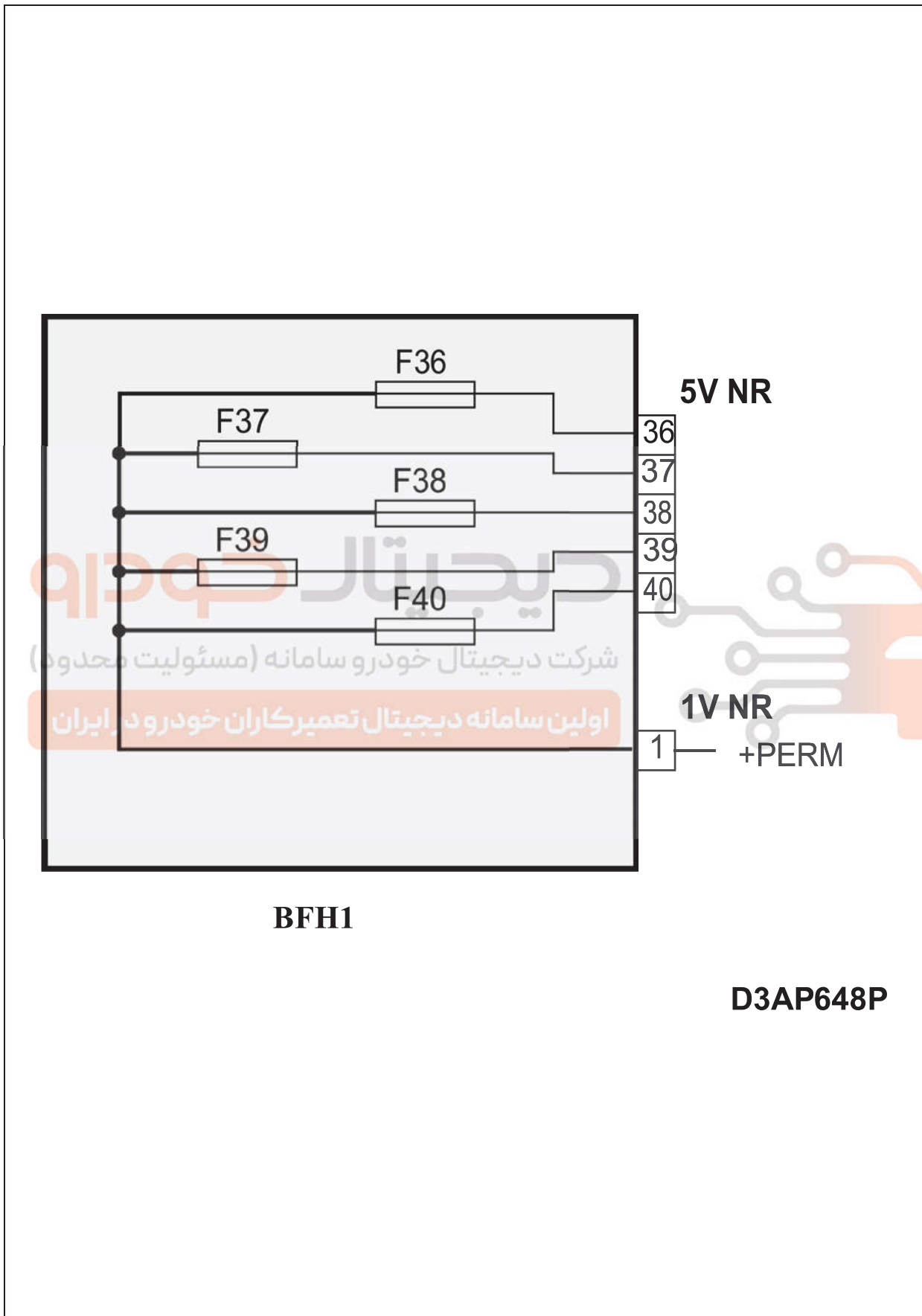

fig. D3AP648P

allocation of BFH1 fuses

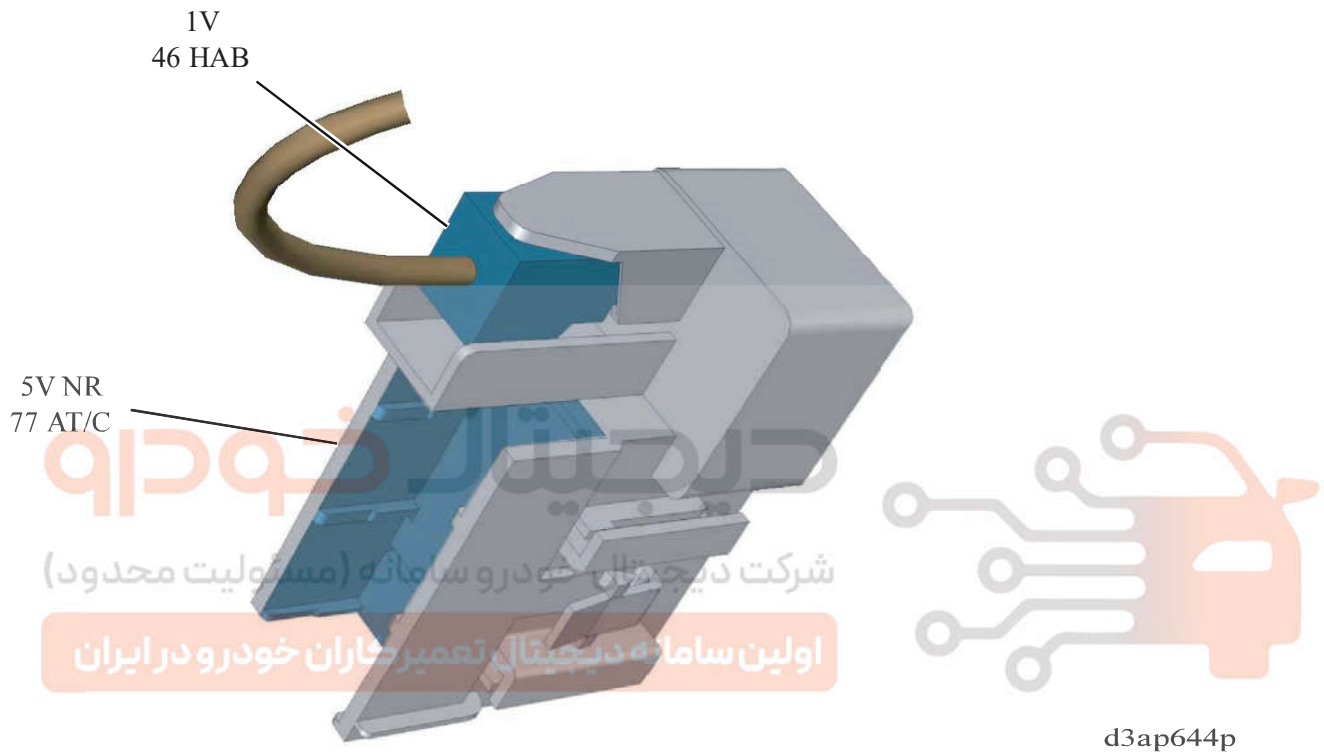
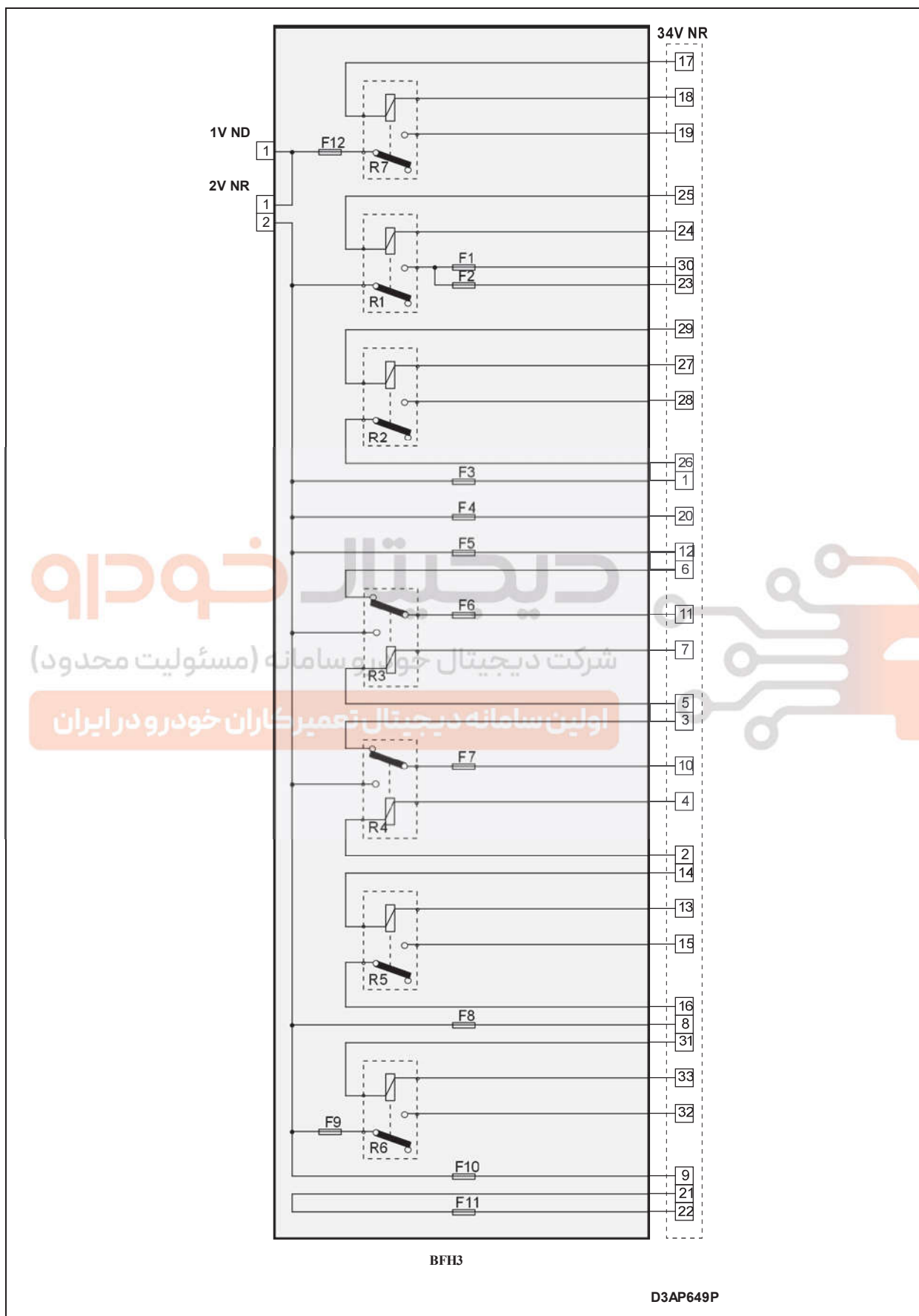

fig. D3AP644P

allocation of BFH1 fuses			
fuse	A	supply	matching
F36	20A	+ BATT	trailer fuse box
F37	20A	+ BATT	trailer fuse box
F38	20A	+ BATT	trailer fuse box
F39	20A	+ BATT	relais remorque
F40	-	-	unused

allocation of BFH3 fuses



allocation of BFH3 fuses

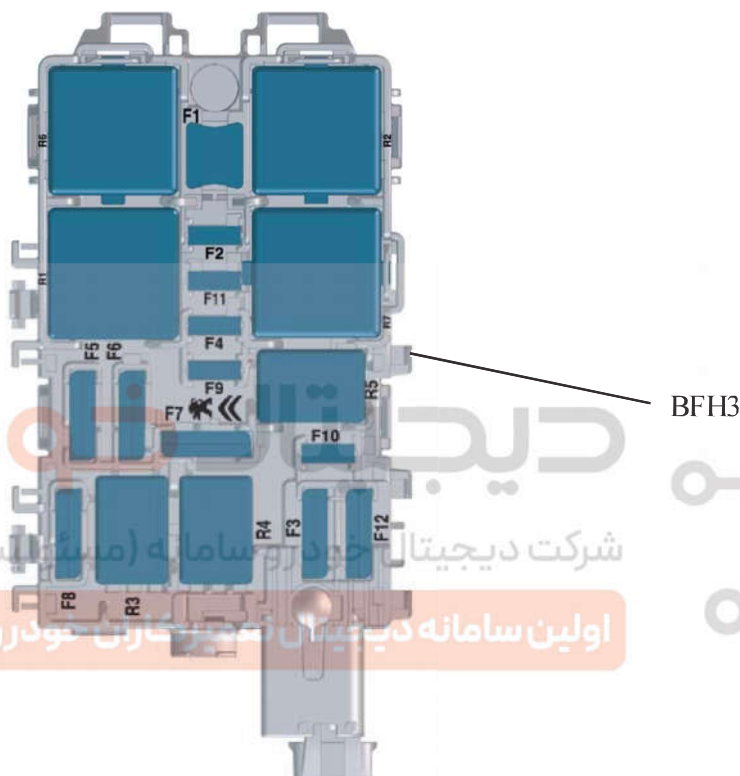

d3ap645p

allocation of BFH3 fuses			
fuse	A	supply	matching
F1	40A	+ BATT commut	heated rear screen
F2	10A	+ BATT commut	heated rear view mirrors
F3	30A	+ BATT	electric windows supply - front sequential windows supply
F4	-	-	unused
F5	30A	+ BATT	rear push operation electric windows supply
F6	10A	+ BATT commut	folding down of door mirrors
F7	10A	+ BATT commut	mirror deployment
F8	20A	+ BATT	vellum supply
F9	15A	+ BATT commut	Heated seat supply
F10	20A	+ BATT	Amplifier supply
F11	-	-	unused
F12	-	-	unused
R1	50A	+ BATT commut	heated rear screen relay
R2	35A	+ BATT commut	electric windows relay
R3	25A	+ BATT commut	rear view mirrors foldback relay
R4	25A	+ BATT commut	rear view mirrors foldback relay
R5	25A	+ BATT commut	vellum relay
R6	35A	+ BATT commut	heated seats relay
R7	-	-	unused

allocation of BFRM fuses

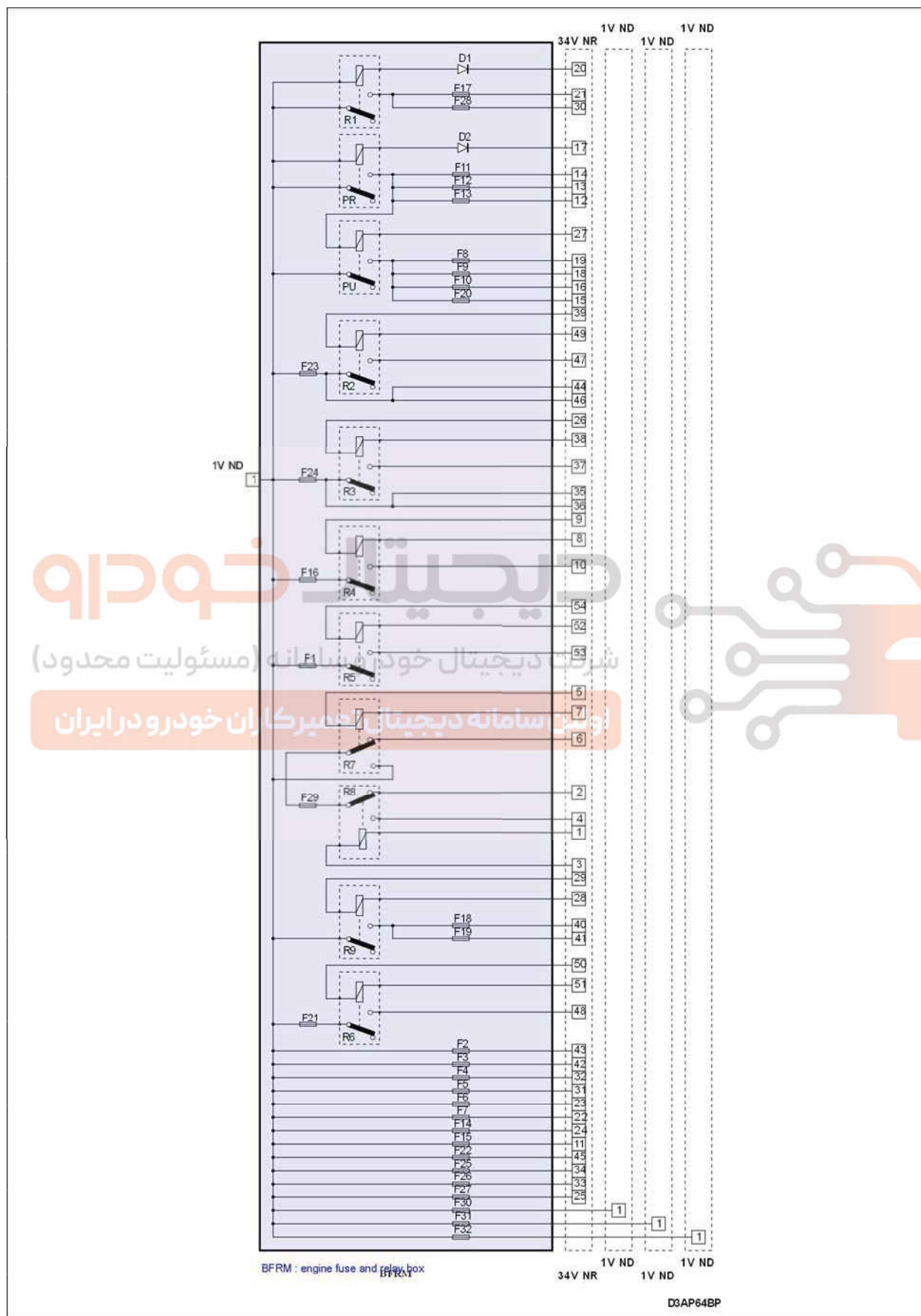

دیجیتال خودرو  
 شرکت دیجیتال خودروسازانه (مسئولیت محدود)  
 واحد سامانه دیجیتال امیرکابان خودرو در ایران

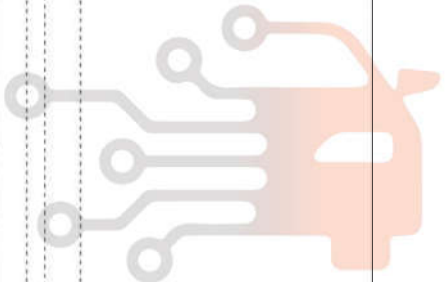

allocation of BFRM fuses

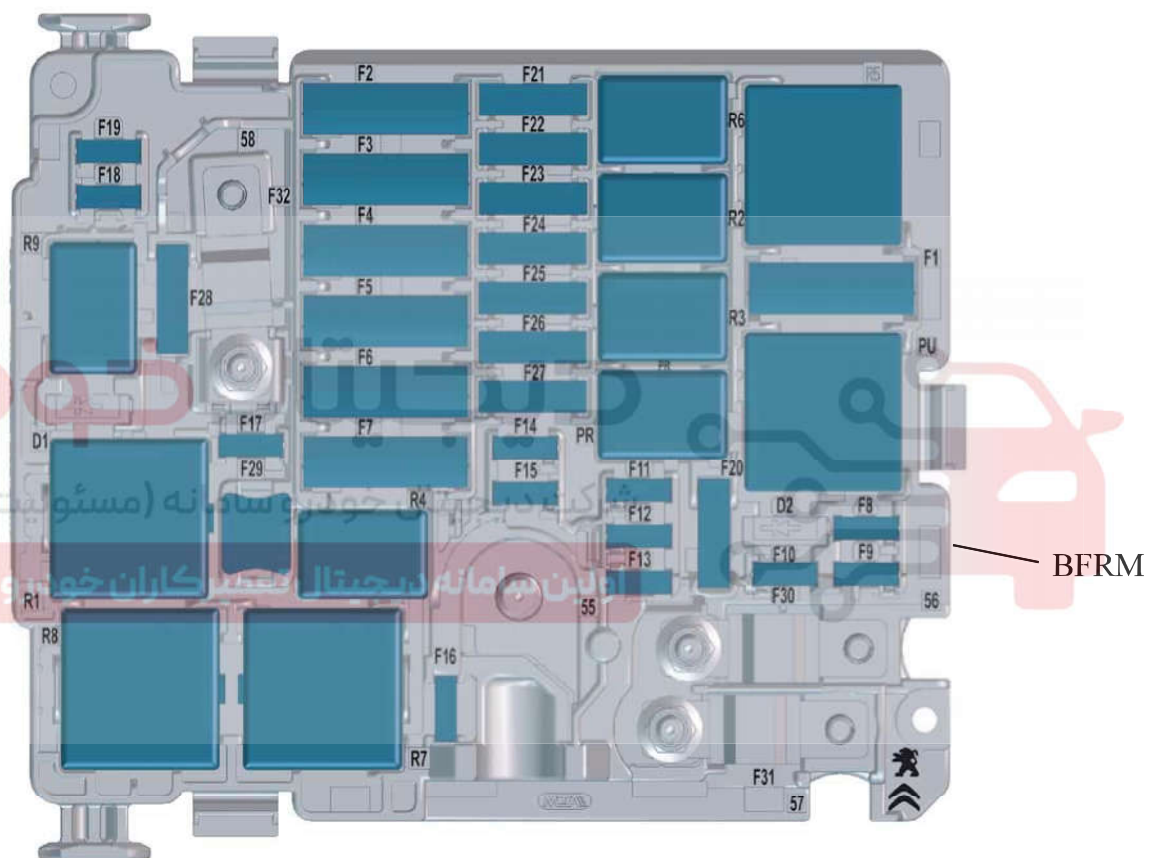

allocation of BFRM fuses

allocation of BFRM fuses			
fuse	A	supply	matching
F1	40A	+ BATT commut	air conditioning blower
F2	40A	+ BATT	central voltage retention device (STTa);(STTd) - network voltage retention device
F3	80A	+ BATT	cabin relay fusebox
F4	80A	+ BATT	cabin relay fusebox
F5	70A	+ BATT	built-in systems interface
F6	60A	+ BATT	dual speed fan assembly electric control unit
F7	80A	+ BATT	built-in systems interface
F8	15A	+ BATT commut	downstream oxygen sensor (EP;EP,EP;1;2;EB;DV;DV engines) - proportional oxygen sensor ( engines) - inlet and exhaust variable timing electrovalves ( engines) - variable timing electrovalves and {4} ({5} engines) - diesel injection pump ({6} engines) - variable geometry turbo regulation electrovalve ({7} engines)
F11	20A	+ BATT commut	engine management ECU - motorised throttle(EB engines)
F12	5A	+ BATT commut	two-speed cooling fan ECU - central voltage retention device (STTa);(STTa) - reversible alternator
F13	5A	+ BATT commut	built-in systems interface
F14	5A	+ BATT	battery charge status unit
F15	5A	+ BATT	Central voltage retention device (STTa)
F16	15A	+ BATT commut	daytime running lamps
F17	5A	+ BATT commut	built-in systems interface
F18	10A	+ BATT commut	right-hand main beam
F19	10A	+ BATT commut	left-hand main beam
F20	30A	+ BATT commut	ignition coils (EB/EP;EP/EB;EB/EP;DV;DV engines) - injectors ( engines) - fuel gauge pump ( engines) - oil vapour resuction heating resistor ( engines) - diesel fuel heater ({4} engines)
F21	30A	+ BATT commut	starter motor
F22	40A	+ BATT	piloted manual gearbox ECU
F23	40A	+ BATT commut	ABS ECU - ESP ECU
F24	20A	+ BATT commut	ABS ECU - ESP ECU
F25	30A	+ BATT	headlamp wash
F26	15A	+ BATT	piloted manual gearbox ECU - automatic gearbox ECU
F27	25A	+ BATT	built-in systems interface
R7	35A	+ BATT	windscreen wipers relay
F29	40A	+ BATT commut	windscreen wiper motor
F30	80A	+ BATT	pre-postheating control unit (DV engines)
F31	100A	+ BATT	passenger compartment air heating element
F32	80A	+ BATT	electric power steering ECU - power steering power relay
R8	35A	+ BATT	windscreen wiper slow and fast speed relay
R9	25A	+ BATT	main beam relay
PU	50A	+ BATT	power relay
PR	25A	+ BATT	Main relay
R1	35A	+ BATT	valve lift motor relay (EP engines)
R2	25A	+ BATT	ABS and ESP ECU relay
R3	25A	+ BATT	ABS and ESP ECU relay
F28	30A	+ BATT commut	variable valve position sensor (DV engines)
R4	25A	+ BATT	daytime running lamps
R5	50A	+ BATT	air conditioning blower relay
R6	25A	+ BATT	starting relay
F9	15A	+ BATT commut	coolant outlet housing (DV engines) - engine coolant pump declutch actuator ( engines) -oil pressure regulation electrovalve ( engines) - oil vapour resuction heating resistor ( engines) - EGR electrovalve ({4} engines) - air flowmeter ({5} engines) - proportional oxygen sensor ({6} engines)
F10	15A	+ BATT commut	canister purge electrovalve (DV engines) - downstream and upstream oxygen sensors ( engines) - water presence sensor ( engines)