

<b>Content</b>		<b>Transmission</b>	
<b>Transmission (6MT)</b>			
I、 Overview .....	1-1	(I) special tools .....	1-21
(I) structure outline .....	1-1	(II) disassembly .....	1-21
(II) system theory .....	1-8	(III) assembly .....	1-24
(III) technical parameters, maintenance parameters .....	1-10	VIII、 Release bearing and fork assy. ....	1-26
(IV) torque parameters .....	1-11	(I) special tools .....	1-26
(V) maintenance precautions .....	1-11	(II) disassembly .....	1-26
(VI) special tools .....	1-12	(III) assembly .....	1-26
II、 Fault diagnosis .....	1-13	IX、 Rear housing .....	1-27
(I) diagnosis sheet .....	1-13	(I) special tools .....	1-27
(II) diagnosis flow sheet .....	1-14	(II) disassembly .....	1-27
III、 Discharge and refueling of transmission oil .....	1-16	(III) assembly .....	1-28
(I) special tools .....	1-16	X、 Reverse gear intermediate shaft assy .....	1-29
(II) discharge and refueling .....	1-16	(I) special tools .....	1-29
IV、 Selecting and shifting gear flexible shaft assy .....	1-17	(II) disassembly .....	1-29
(I) special tools .....	1-17	(III) assembly .....	1-29
(II) disassembly .....	1-17	XI、 Selecting and shifting gear fork and fork shaft .....	1-30
(III) assembly .....	1-18	(I) special tools .....	1-30
V、 Operating mechanism with hand lever assy .....	1-20	(II) disassembly .....	1-30
(I) special tools .....	1-20	(III) assembly .....	1-30
(II) disassembly .....	1-20	XII、 Input and output shaft assy. ....	1-31
(III) assembly .....	1-20	(I) special tools .....	1-31
VI、 Selecting and shifting gear base assy ....	1-20	(II) disassembly .....	1-32
(I) special tools .....	1-20	(III) dismantling .....	1-33
(II) disassembly .....	1-20	(IV) inspection .....	1-39
(III) assembly .....	1-21	(V) assembly .....	1-41
VII、 Transmission assy. ....	1-21	(VI) mounting .....	1-50
		XIII、 Differential lock assy .....	1-50
		(I) special tools .....	1-50
		(II) disassembly .....	1-50
		(III) dismantling .....	1-51
		(IV) assembly .....	1-54
		(V) mounting .....	1-55

		<b>Transmission</b>	
Transmission (CVT)			
I、 Overview .....	2-1	(V) inspection .....	2-41
(I) structure outline .....	2-1	VII、 Shifting gear rocker arm and sleeve ...	2-41
(II) system theory .....	2-5	(I) special tools .....	2-41
(III) technical parameters, maintenance parameters .....	2-11	(II) disassembly .....	2-41
(IV) torque parameters .....	2-11	(III) assembly .....	2-41
(V) maintenance precautions .....	2-12	(IV) inspection .....	2-41
(VI) special tools .....	2-12	VIII、 Selecting gear wire drawing assy. ....	2-42
II、 Fault diagnosis .....	2-14	(I) special tools .....	2-42
(I) diagnosis sheet .....	2-14	(II) disassembly .....	2-42
(II) noise description .....	2-15	(III) assembly .....	2-43
(III) noise problem's check and maintenance .....	2-16	(IV) inspection .....	2-43
(IV) malfunction code and measurement .....	2-20	IX、 Transmission control mechanism assy. ...	2-43
III、 Driving strategy .....	2-32	(I) special tools .....	2-43
(I) parking gear and neutral gear's functional characteristic .....	2-32	(II) disassembly .....	2-43
(II) function of D gear and R gear .....	2-32	(III) assembly .....	2-44
(III) malfunction default pattern .....	2-33	(IV) inspection .....	2-44
IV、 Self-adaptive update .....	2-33	X、 Differential lock oil seal .....	2-44
(I) introduction .....	2-33	(I) special tools .....	2-44
(II) requirement .....	2-34	(II) disassembly .....	2-44
(III) procedure .....	2-34	(III) assembly .....	2-45
(IV) common problems .....	2-37	XI、 Input shaft oil seal .....	2-45
V、 Transmission oil .....	2-38	(I) special tools .....	2-45
(I) special tools .....	2-38	(II) disassembly .....	2-45
(II) oil level check description .....	2-38	(III) assembly .....	2-46
(III) oil level check .....	2-39	XII、 Selecting gear shaft oil seal .....	2-46
VI、 Shifting gear lever assy. ....	2-39	(I) special tools .....	2-46
(I) special tools .....	2-39	(II) disassembly .....	2-47
(II) disassembly .....	2-40	(III) assembly .....	2-48
(III) assembly .....	2-40	XIII、 Driving cone gear end cap .....	2-48
(IV) adjustment .....	2-40	(I) special tools .....	2-48
		(II) disassembly .....	2-48
		(III) assembly .....	2-48
		XIV、 Oil pump .....	2-48

		<b>Transmission</b>
(I) special tools.....	2-48	(II) disassembly ..... 2-57
(II) disassembly.....	2-49	(III) assembly..... 2-58
(III) assembly .....	2-49	XXIII、 Main connector and internal harness 2-58
XV、 Driving cone axle ball bearing .....	2-50	(I) special tools ..... 2-58
(I) special tools.....	2-50	(II) disassembly ..... 2-58
(II) disassembly.....	2-50	(III) assembly..... 2-59
(III) assembly .....	2-51	XXIV、 Breather pipe .....
XVI、 Driven cone axle end cap.....	2-52	(I) special tools ..... 2-60
(I) special tools.....	2-52	(II) disassembly ..... 2-60
(II) disassembly.....	2-52	(III) assembly..... 2-60
(III) assembly .....	2-52	XXV、 Electric appliance schematic .....
XVII、 Oil sump .....	2-52	(I) TCU connector diagram .....
(I) special tools.....	2-52	(II) Electronic components inspection chart .2-66
(II) disassembly.....	2-52	(III) transmission system circuit diagram ...2-68
(III) assembly .....	2-53	
XVIII、 Oil filter.....	2-53	
(I) special tools.....	2-53	
(II) disassembly.....	2-53	
(III) assembly .....	2-53	
XIX、 Driving pattern sensor .....	2-53	
(I) special tools.....	2-53	
(II) disassembly.....	2-53	
(III) assembly .....	2-54	
XX、 Hydraulic control block .....	2-54	
(I) special tools.....	2-54	
(II) disassembly.....	2-55	
(III) assembly .....	2-55	
XXI、 Driven cone pulley speed sensor and bracket .....	2-56	
(I) special tools.....	2-56	
(II) disassembly.....	2-56	
(III) assembly .....	2-57	
XXII、 Driving cone pulley speed sensor ....	2-57	
(I) special tools.....	2-57	

# Transmission (6MT)

## I Overview

### ( I ) Structural outline

The name and meaning of transmission

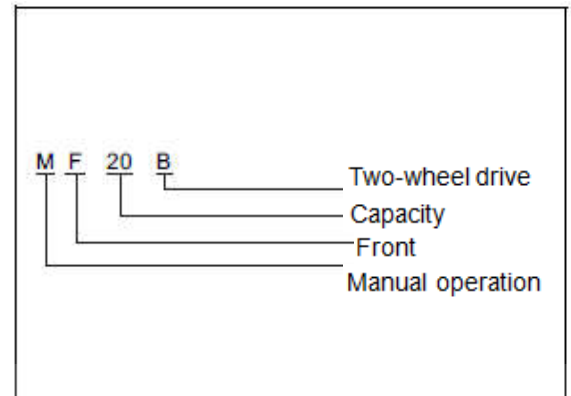

Structural form

Manual shifting gear mechanical transmission, with six forward gears and a reverse gear; the shifting gear mechanism uses cable.

Gears diagram.

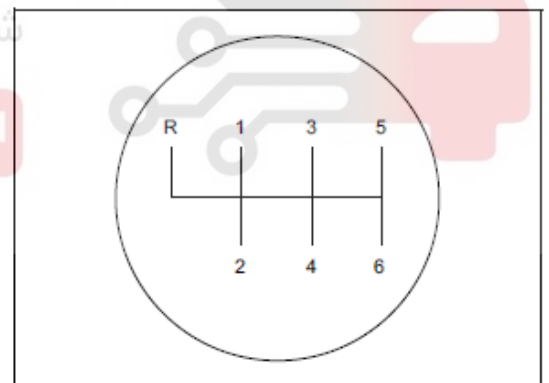

Exploded view

Transmission operating system

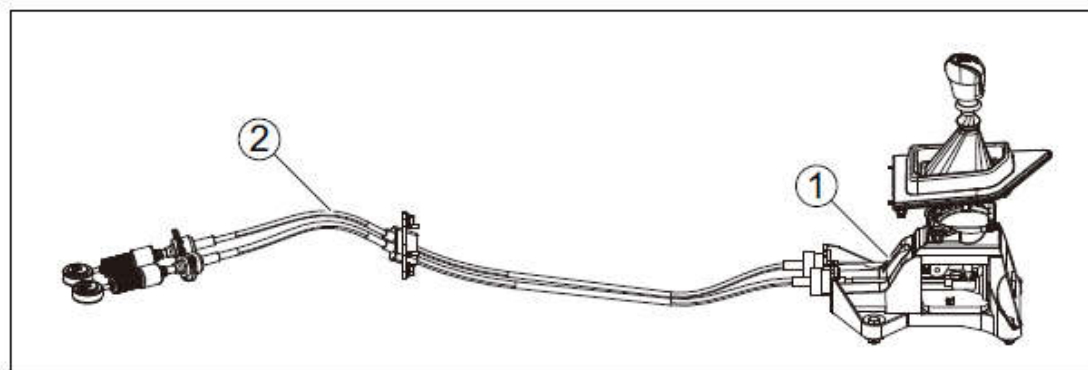

1. Transmission operating mechanism with hand lever assy.

2. Shifting gear flexible shaft.

## 6MT Transmission

## Transmission assembly

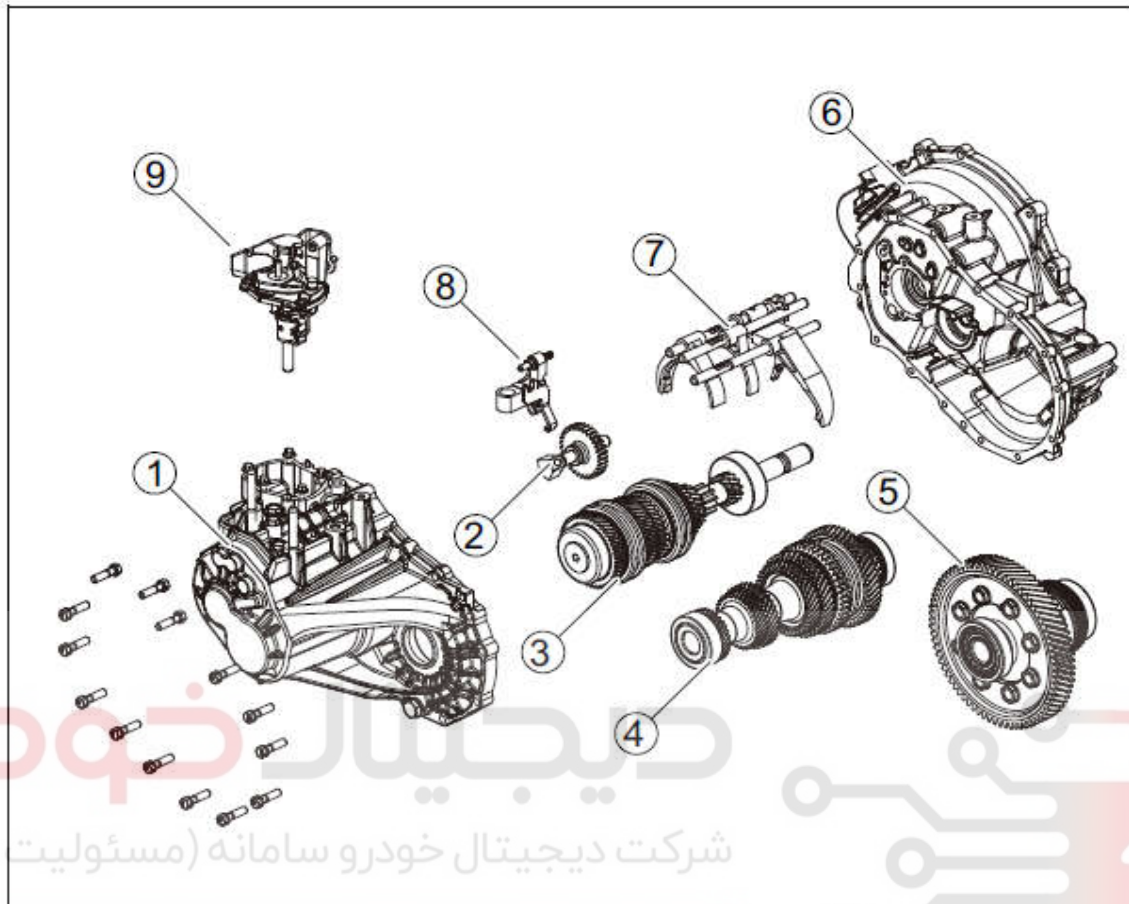

دیجیتال خودرو  
شرکت دیجیتال خودرو سامانه (مسئولیت محدود)

اولین سامانه دیجیتال تعمیرکاران خودرو در ایران

- |   |  |
|---|--|
| 1. transmission housing assy            | 6. transmission housing assy                       |
| 2. reverse gear intermediate shaft assy | 7. selecting and shifting gear shaft and fork assy |
| 3. input shaft assy                     | 8. reverse gear base assy                          |
| 4. output shaft assy                    | 9. selecting and shifting gear base assy           |
| 5. differential lock assy               |  |

Selecting and shifting gear base assy

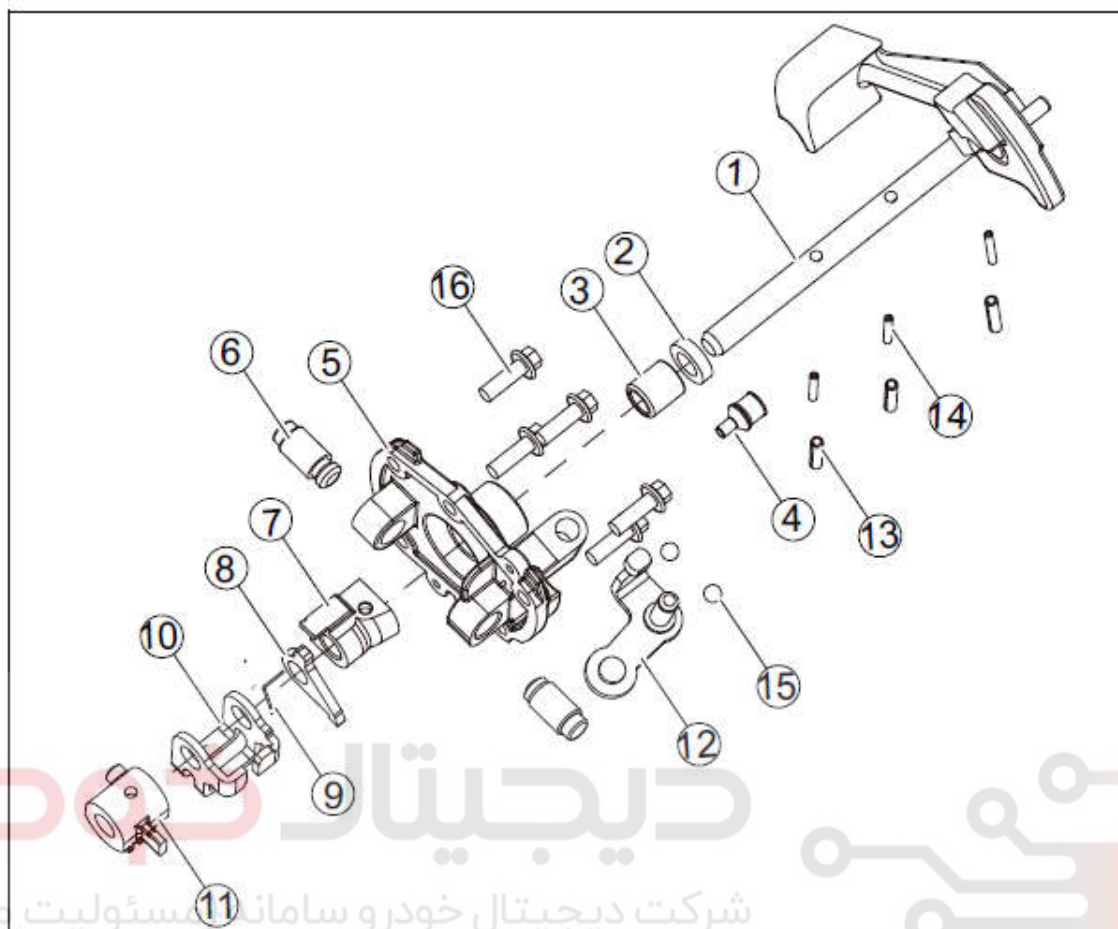

1.shift gear shaft subassembly

2.select and shift gear shaft oil seal

3.linear bearing

4.gas outlet valve

5.select and shift gear base

6.select and shift gear resistance pin

7.select and shift gear block

8.reverse gear paddle

9.reverse gear paddle torsion spring

10.interlock plate

11.shift gear ball

12.select gear arm subassembly

13.elastic cylindrical pin

14. cylindrical pin

15.bushing

16.flange bolt

6MT Transmission

Housing assembly

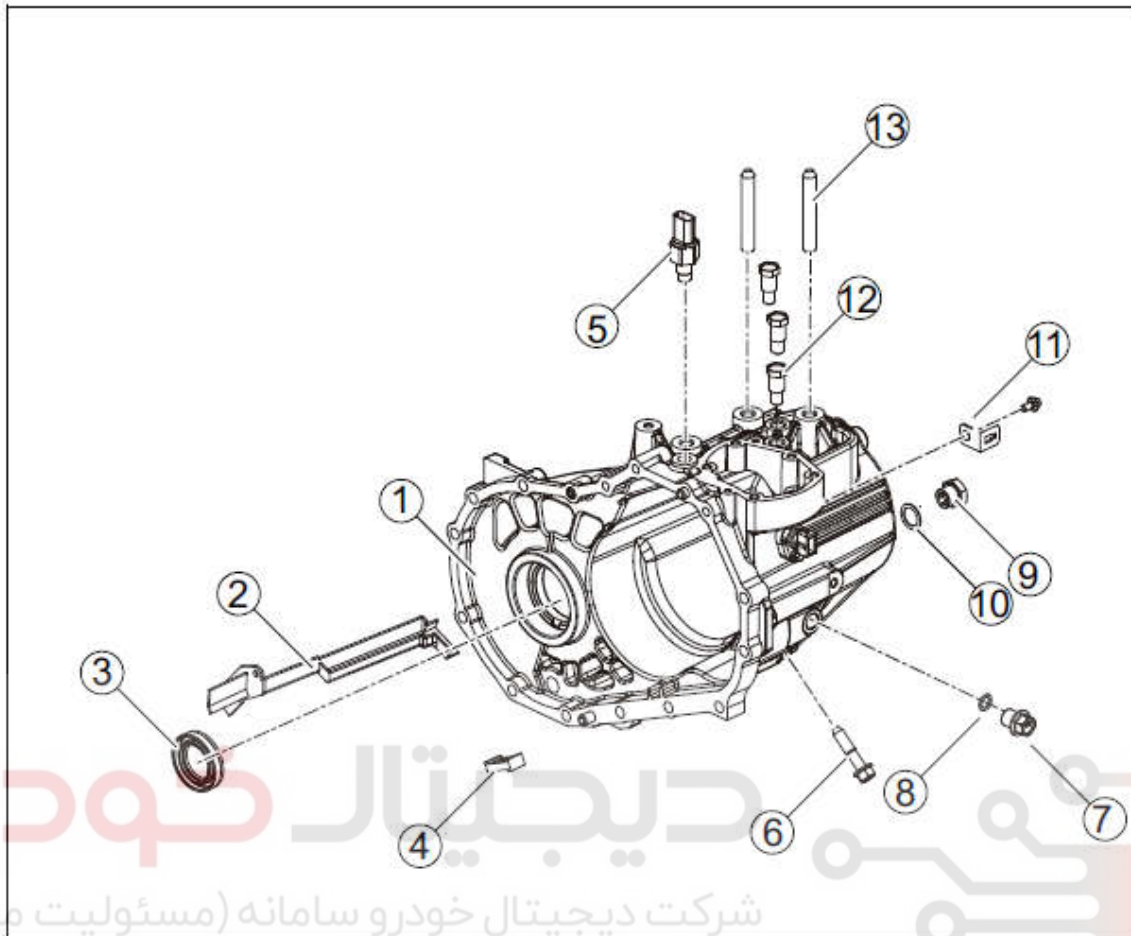

- |   |                              |
|---|------------------------------|
| 1.housing                                   | 8.gasket                     |
| 2.oil groove                                | 9.drain plug assy            |
| 3.oil seal(differential lock)               | 10.spring gasket             |
| 4.magnet                                    | 11.harness bracket           |
| 5.back-up light switch gasket(drain plug)   | 12.self-lock pin subassembly |
| 6.reverse gear shaft bolt gasket(fill plug) | 13.stud                      |
| 7.oil fill plug                             |                              |

## 6MT Transmission

## Transmission housing assembly

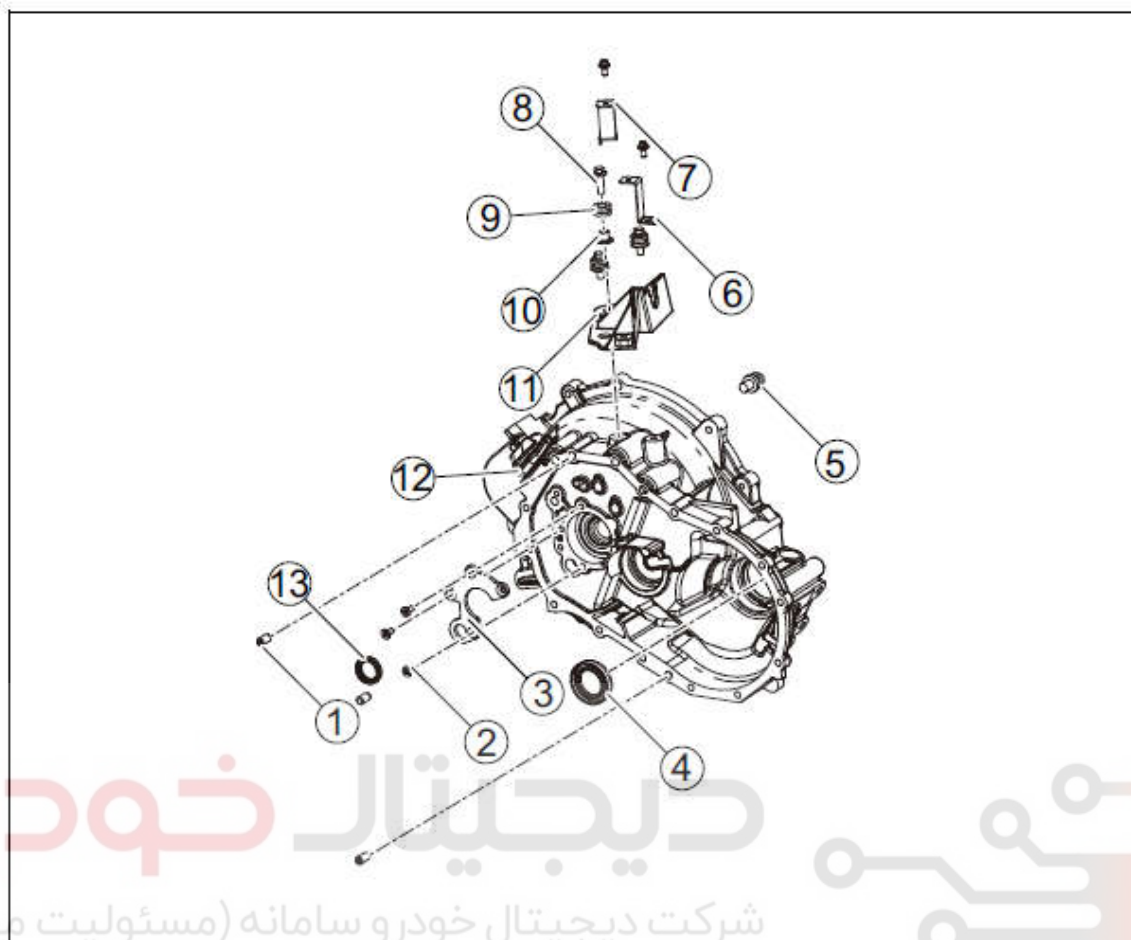

- |   |                         |
|---|-------------------------|
| 1.locating pin                                    | 8.shock pad support     |
| 2.bearing pressure plate bolt                     | 9.bracket shock pad     |
| 3.bearing pressure plate                          | 10.flange bolt          |
| 4.oil seal(differential lock)transmission housing | 11.wire drawing bracket |
| 5.ball support                                    | 12.transmission housing |
| 6.harness stator                                  | 13.oil deflector plate  |
| 7.harness stator                                  |                         |



## Input draft assembly

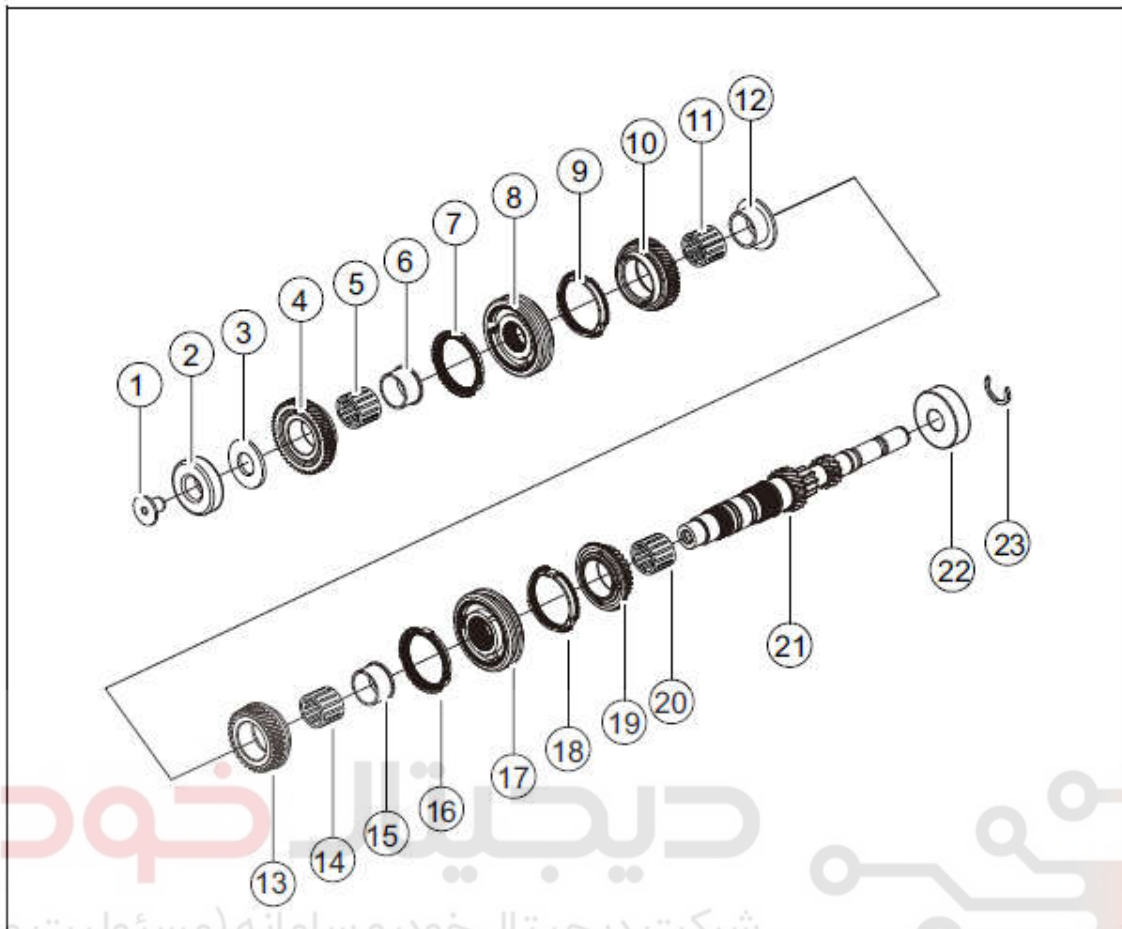

- |  |  |
|--|--|
| 1. plug                                    | 13. input fourth gear tooth subassemblies      |
| 2. ball bearing (behind the input shaft)   | 14. input fourth gear needle bearing           |
| 3. input sixth gear thrust gasket          | 15. input fourth gear bushing                  |
| 4. input sixth gear tooth subassemblies    | 16. fourth gear synchronizing ring             |
| 5. input sixth gear needle bearing         | 17. 3/4 synchronizer assembly                  |
| 6. input sixth gear bushing                | 18. third gear synchronizing ring elements     |
| 7. fifth and sixth gear synchronizing ring | 19. input third gear tooth subassemblies       |
| 8. 5/6 synchronizer assembly               | 20. input third gear needle bearing            |
| 9. fifth and sixth gear synchronizing ring | 21. input shaft                                |
| 10. input fifth gear tooth subassemblies   | 22. ball bearing (in front of the input shaft) |
| 11. input fifth gear needle bearing        | 23. snap ring (in front of the input shaft)    |
| 12. input fifth gear bushing               |  |

## 6MT Transmission

## Output shaft assembly

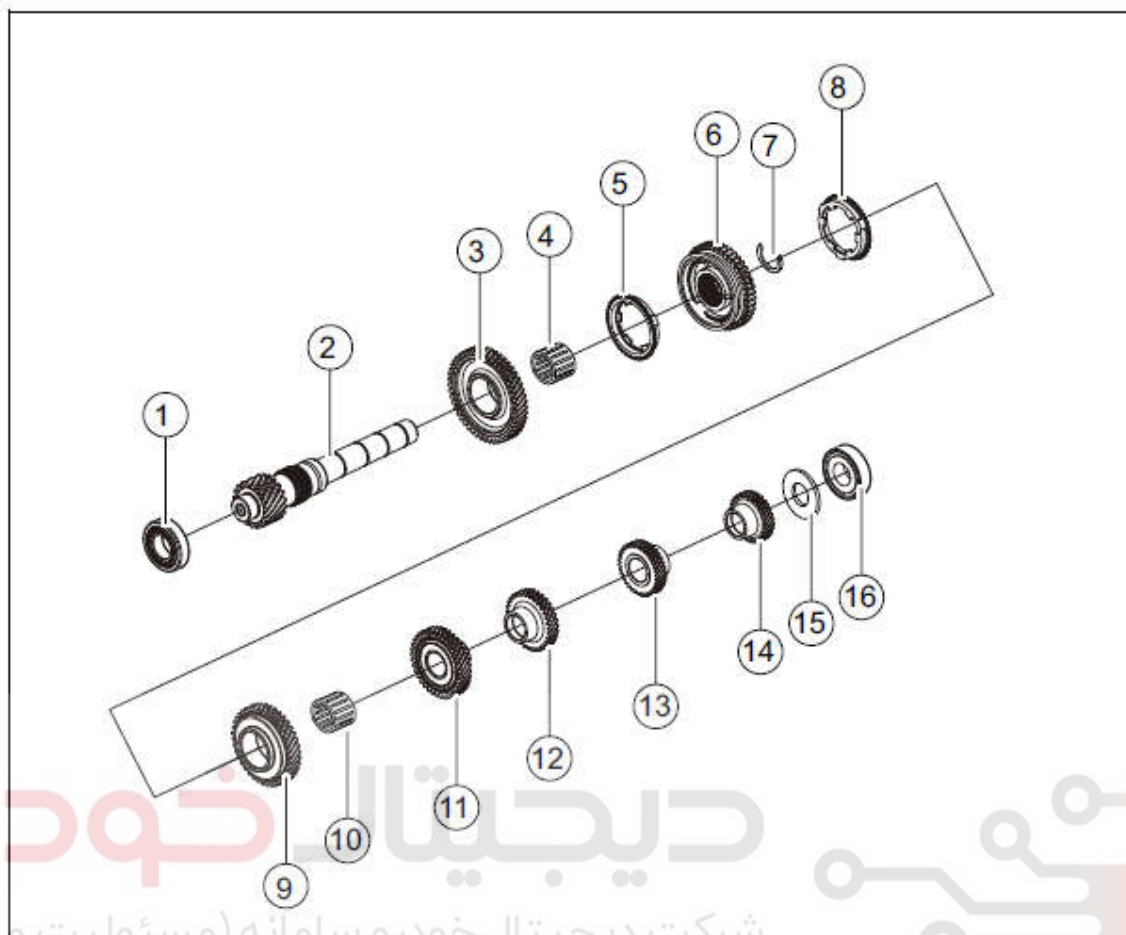

1. conical roller bearing (in front of the input shaft)

2. output shaft

3. output first gear tooth

4. output first gear needle bearing

5. first gear synchronizing ring elements

6. 1/2 synchronizer assy

7. 1/2 synchronizer snap ring

8. second gear synchronizing ring elements

9. output second gear tooth

10. output second gear needle bearing

11. output third gear tooth

12. output fourth gear tooth

13. output fifth gear tooth

14. output sixth gear tooth

15. adjustment gasket (output shaft rear bearing)

16. conical roller bearing (behind the input shaft)

## Differential lock assembly

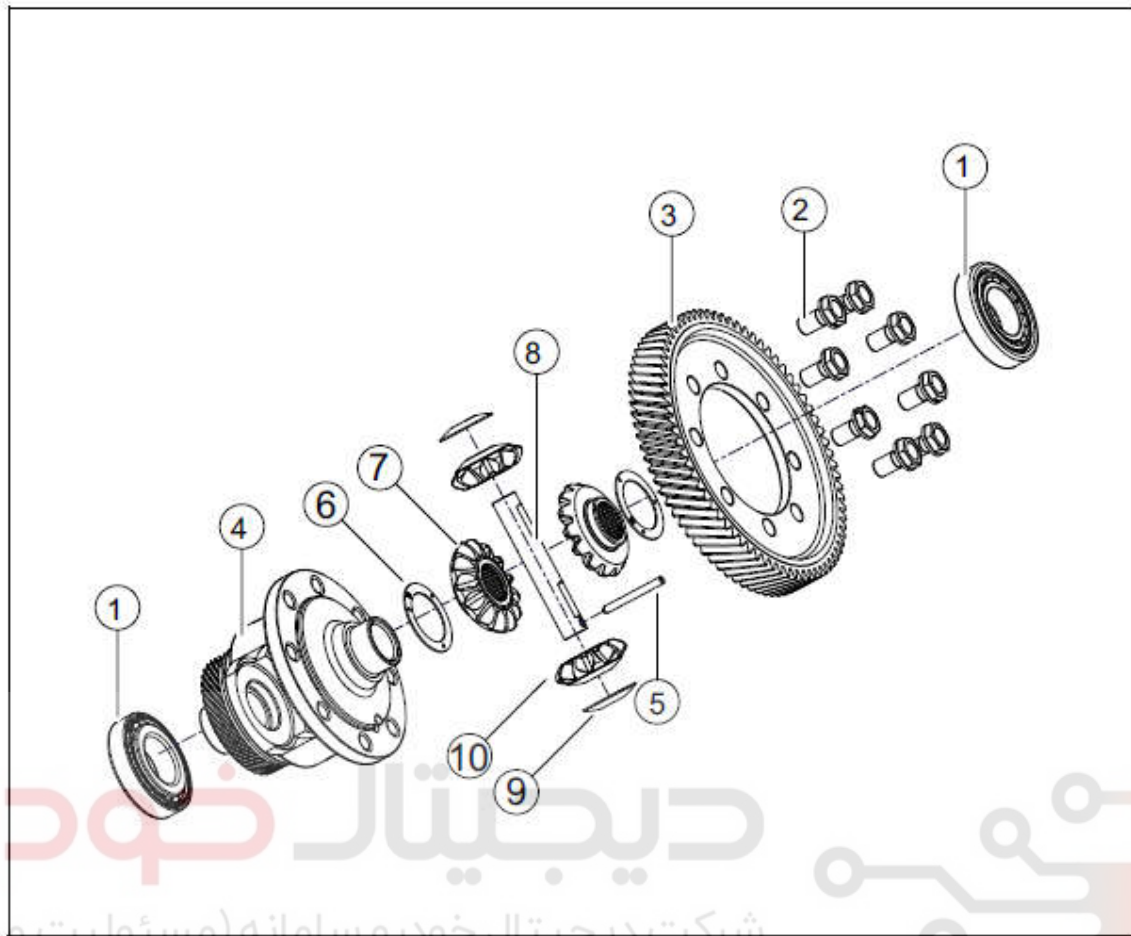

1. conical roller bearing

2. hexagon bolt

3. final drive gear

4. differential lock housing

5. groove pin

6. half axle gear thrust gasket

7. half axle gear

8. planet gear shaft

9. planet gear thrust gasket

10. planet gear

## ( II ) System theory

## System operating principle

Because the variation range of engine's output torque and rotate speed is quite narrow which cannot meet the need for driving in complicated condition demanded with large variation range of traction and speed. For engine's output torque and rotate speed, transmission enlarges driving wheel's torque and rotate speed by changing the transmission ratio. This makes the vehicle can adapt the variable condition of usage.

## 6MT Transmission

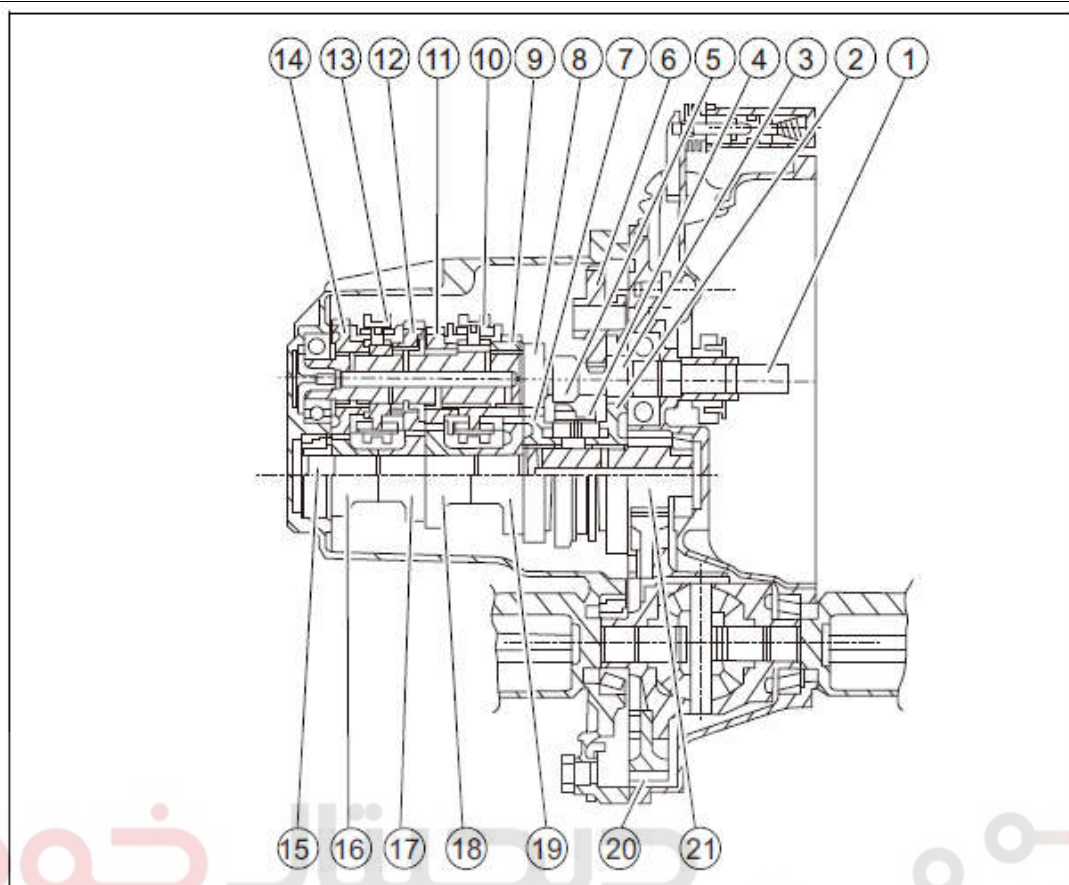

Reverse gear's working state:

Engine---clutch---input shaft spline 1---input reverse gear tooth 5---reverse gear idler 6---1/2 gear synchronizer 4---output shaft 15---output shaft final drive gear 21---differential lock 20

1st gear working state:

Engine---clutch---input shaft spline 1---input 1st gear tooth 3---input 1st gear tooth 2---1/2 gear synchronizer 4---output shaft 15---output shaft final drive gear 21---differential lock 20

2nd gear working state:

Engine---clutch---input shaft spline 1---input 2nd gear tooth 6---input 2nd gear tooth 7---1/2 gear synchronizer 4---output shaft 15---output shaft final drive gear 21---differential lock 20

3rd gear working state:

Engine---clutch---input shaft spline 1---3/4 gear synchronizer 10---input 3rd gear tooth 9--- output 3rd gear tooth 19--- output shaft 15---output shaft final drive gear 21---differential lock 20

4th gear working state:

Engine---clutch---input shaft spline 1---3/4 gear synchronizer 10---input 3rd gear tooth 9--- output 3rd gear tooth 19--- output shaft 15---output shaft final drive gear 21---differential lock 20

5th gear working state:

Engine---clutch---input shaft spline 1---5/6 gear synchronizer 13---input 5th gear tooth 12--- output 5th gear tooth 17--- output shaft 15---output shaft final drive gear 21---differential lock 20

6th gear working state:

Engine---clutch---input shaft spline 1---5/6 gear synchronizer 13---input 6th gear tooth 14--- output 6th gear tooth 16--- output shaft 15---output shaft final drive gear 21---differential lock 20

## 6MT Transmission

### Operating principle

By controlling the control lever in cab, we can eventually manipulate selecting and shifting gear rocker arm to select or shift gears. Directions showed on the hand ball on control lever are in accord with the different select and shift gear location. Every time you put out the gear, lever will return to neutral gear; only if you are in neutral gear, you can select gears, and you can only shift reverse gear by pull up the reverse gear lock on the control lever.

1、 While shifting gears, fully step on the release pedal, to let the transmission get off the engine's torsion. Then manipulate the gear shift lever quickly. Please use low speed gear when you start the vehicle.

2、 Please use low speed gear in climbing uphill or downhill and turning a corner. Do not slide with cutting-off the transmission.

3、 If you find any difficulty on manipulating gear shift lever, please stop to check for reasons, and do not push it so hard.

Recommended speed under corresponding transmission gears:

Gear	1 <sup>st</sup> gear	2 <sup>nd</sup> gear	3 <sup>rd</sup> gear	4 <sup>th</sup> gear	5 <sup>th</sup> gear	6 <sup>th</sup> gear
Speed (km/h)	0~20	10~30	20~40	40~60	60~80	80~max

△Notice:

1、 Gear shift should be done within the corresponding speed.

2、 Gears of the transmission mounted in different models of vehicles are in accord with different speed range.

### Gear shifting principle

While driving forward, gear shifting principles are: shift gears one by one from 1 to 6 both in speeding up and slowing down; do not shift into reverse gear while driving. In order to avoid mistakes, the transmission set a lock which makes driver cannot shift reverse gear from 6<sup>th</sup> gear. You should shift reverse gear 3 seconds after stepping on clutch; do not shift reverse gear while driving; as well, do not shift forward gears while backing up.

△Notice: You can violate the gear shifting principle only in emergency while driving.

## (III) Technical parameters, maintenance parameters

### Technical parameters

Driving mode	2 front wheel-driving
Number of gears	6
Clutch operation	Hydraulic
Weight (kg)	40 (without oil)
Transmission lubrication oil standard	75W/90(GL-4)
Transmission lubrication oil refilling method	Refill with the standard quantity from the side filler
Transmission lubrication oil capacity	2.0 (+0.2,0) L

### Transmission ratio

Control mode	Remote operation	
Input rated torque	180 N·m	
Model	MF20B1	
Ratio	1 <sup>st</sup> gear	3.769
	2 <sup>nd</sup> gear	2.053
	3 <sup>rd</sup> gear	1.393
	4 <sup>th</sup> gear	1.031
	5 <sup>th</sup> gear	0.778
	6 <sup>th</sup> gear	0.681
	Reverse gear	3.583
Final drive ratio	4.056	

## 6MT Transmission

## (IV) Torque parameters

No	Items	Torque (N·m)	Remark
Transmission operation			
1	Select and shift gear wire drawing and vehicle body fixed bolt	20~30	
2	Fixed bolt of select and shift gear operating device	20~30	
3	Transmission lower board	8~12	
4	Fixed bolt between transmission and engine	35~45	
Transmission assembly			
1	Differential mechanism housing and final drive connecting bolt	75~85	Precoat thread-locking adhesives
2	Drain plug	40~60	Smear silicone sealant
3	Bolt and washer fitting (housing and clutch housing)	34.3~41.2	Precoat thread-locking adhesives
4	Hexagon flange bolt (housing and clutch housing)	34.3~41.2	Precoat thread-locking adhesives
5	Reverse gear shaft bolt	42.2~53.9	Smear high strength thread glue in central of thread
6	Refuel plug	30~40	Smear silicone sealant
7	Backup light switch	29.4~34.3	Precoat thread-locking adhesives
8	Flange bolt (select and shift gear base mounting bolt, wire drawing bracket)	25~30	Precoat thread-locking adhesives
9	Hexagon flange bolt (harness fixed bolt)	8~12	Precoat thread-locking adhesives
10	Self-lock pin fitting	30~40	Precoat thread-locking adhesives
11	Ball head support	32~40	Precoat thread-locking adhesives
12	Plug	75~85	Precoat thread-locking adhesives
13	Guide pin	15~22	Precoat thread-locking adhesives
14	Hexagon socket cap screw (shift gear supporting base bolt)	15~22	Precoat thread-locking adhesives
15	Hexagon flange bolt (wheel cylinder mounting bolt)	22~28	Precoat thread-locking adhesives
16	Bearing pressure plate bolt	8~12	Precoat thread-locking adhesives
17	Stud	35~45	Precoat thread-locking adhesives

## (V) Maintenance precautions

- In the process of diagnosis and maintenance, you must obey the standard of safety and regulation to avoid injury for people and damage for vehicle.
- When disassemble the transmission for repairing, do not let the dust get into it; must use special tools for repairing transmission, so that the repairing efficiency and quality can be improved and damages won't be occurred on vehicles.
- Do not reuse drained transmission gear oil.
- When examine and replace transmission gear oil, remember that change oil has no relevance with cleaning parts; please keep the vehicle level.
- Keep the inside clean when dismount and mount transmission.
- Before dismount and mount transmission, please check for the right mounting position. If you need to remark, make sure it won't influence the function of parts.
- According to the regulation, you should follow multi steps and be in accord with the diagonal order; tighten the middle on first and then the outside bolts and nuts. If the tightening order is demanded, please follow the requirement.
- Do not damage the sliding surface and fitting surface.
- Before assembling needle bearings, please smear lubricating grease on circular surface.
- Before assembling oil seal, please smear lubricating grease on its lip.
- When press-fitting synchronizer units, please match the synchronizer sliding block with the block groove on synchronizer ring first.

## 6MT Transmission

## (VI) Special tools

No.	Tools No.	Tool name	Outside view	Function
1	27G0059	Differential mechanism oil seal mounting tool		Mount differential oil seal
2	27G0060	Shift fork shaft fixed pin compacter		Dismount shift fork shaft fixed pin
3	27G0061	Backup light switch sleeve		Dismount backup light switch
4	27G0062	Mounting tool of input shaft oil seal		Mount input shaft oil seal
5	27G0063	Dismount and mount heel block of differential bearing		Dismount and mount differential bearing
6	27G0064	Mounting tool of differential bearing		Mount differential bearing
7	27G0065	Dismount and mount heel block of input shaft		Dismount and mount input shaft and synchronizer
8	27G0066	Mounting tool of input shaft 6 <sup>th</sup> gear sleeve		1.mount input shaft 6 <sup>th</sup> gear sleeve 2.mount input shaft rear end bearing 3.mount output shaft end bearing
9	27G0067	Mounting tool of 4 <sup>th</sup> and 5 <sup>th</sup> gear sleeve		Mount 4 <sup>th</sup> and 5 <sup>th</sup> gear sleeve
10	27G0068	Mounting tool of input shaft front bearing		Mount input shaft front bearing
11	27G0069	Mounting tool of output shaft front bearing outer ring		Mount output shaft front bearing outer ring
12	27G0070	Mounting tool of output shaft rear bearing outer ring		Mount output shaft rear bearing outer ring
13	27G0071	Mounting tool of differential bearing outer ring		Mount differential bearing outer ring
14	27G0072	Mounting tool of select-gear shaft oil seal		Mount select-gear shaft oil seal
15	27G0073	Mounting tool of select-gear shaft linear bearing		Mount select-gear shaft linear bearing
16	27G0074	Dismount and mount heel block of output shaft		Dismount and mount output shaft gear and synchronizer
17	27G0075	Dismounting tool of 4 <sup>th</sup> , 5 <sup>th</sup> and 6 <sup>th</sup> gear tooth		Dismount 4 <sup>th</sup> , 5 <sup>th</sup> and 6 <sup>th</sup> gear tooth
18	27G0076	Dismounting tool of 3 <sup>rd</sup> gear tooth		Dismount 3 <sup>rd</sup> gear tooth
19	27G0077	Mounting tool of output shaft gear		Mount output shaft 3 <sup>rd</sup> , 4 <sup>th</sup> , 5 <sup>th</sup> and 6 <sup>th</sup> gear tooth
20	27G0078	Mounting tool of output 1 <sup>st</sup> gear synchronizer		Mount output 1 <sup>st</sup> gear synchronizer

## 6MT Transmission

## II Fault diagnosis

## ( I ) Diagnosis sheet

No.	Fault phenomenon	Fault reason analysis	Solutions	Remark
1	Vibration, noise	Connecting place of engine and transmission is loosen up	Tightening	Refer to the flow diagram of transmission vibration and noise
		Axial clearance between gears is too big	Adjust the clearance	
		Wearing of gears	Replace	
		Deterioration of lubricating oil	Change gear oil	
		Lack of lubricating oil	Refuelling	
		Damage of bearing	Replace	
		Unstability of engine idle speed	Adjust the speed in idle	
2	Oil leakage	Damage of oil seal	Replace an oil seal	
3	Shift-gear difficulty	Damage of operating wire drawing	Replace the operating wire drawing	Refer to the flow diagram of shift-gear difficulty
		Poor match or wearing between synchronizer ring and gear conical face	Replace or repair	
		Failure of synchronizer sliding block	Replace a synchronizer sliding block	
		Wrong model of gear oil	Change the gear oil	
4	Easy to jump gears	Wearing on upper engage tooth or side cone of sleeve	Replace the gear or tooth sleeve	
		Shift-gear fork wearing or the ball lock spring breaks off	Replace the fork or ball lock spring	
		Clearance between synchronizer hub and tooth sleeve is too big	Replace the synchronizer tooth hub and tooth sleeve	



( II ) Diagnosis flow diagram

Flow diagram of shift-gear difficulty

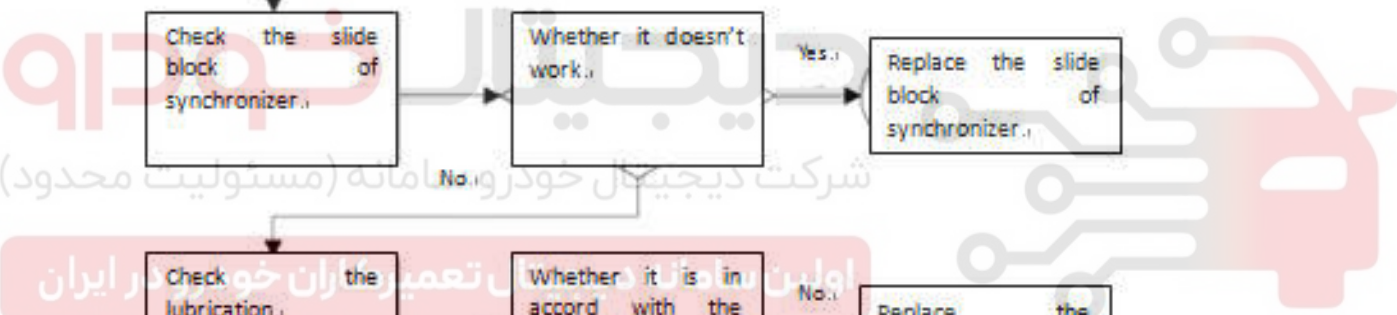
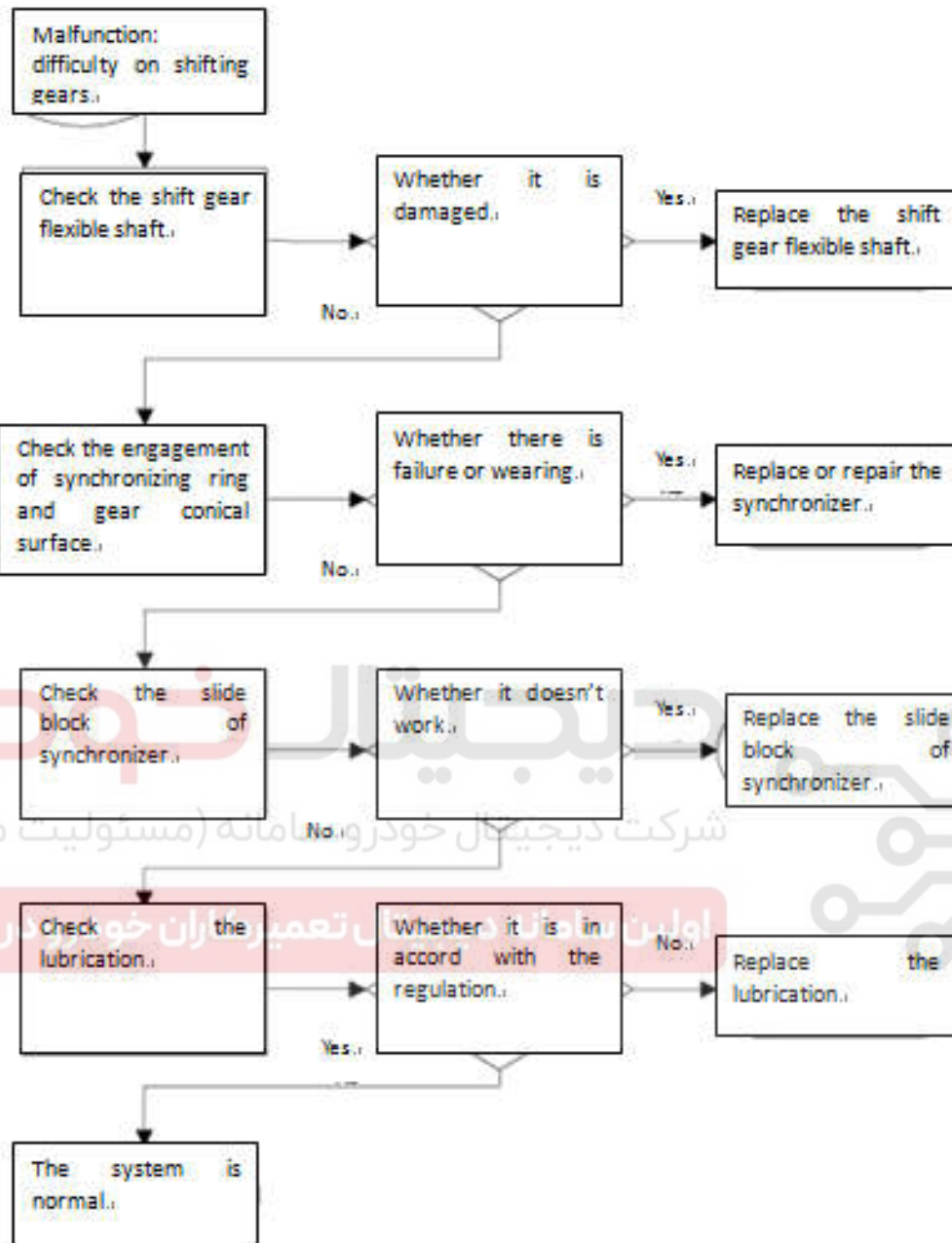

Flow diagram of transmission vibration and noise

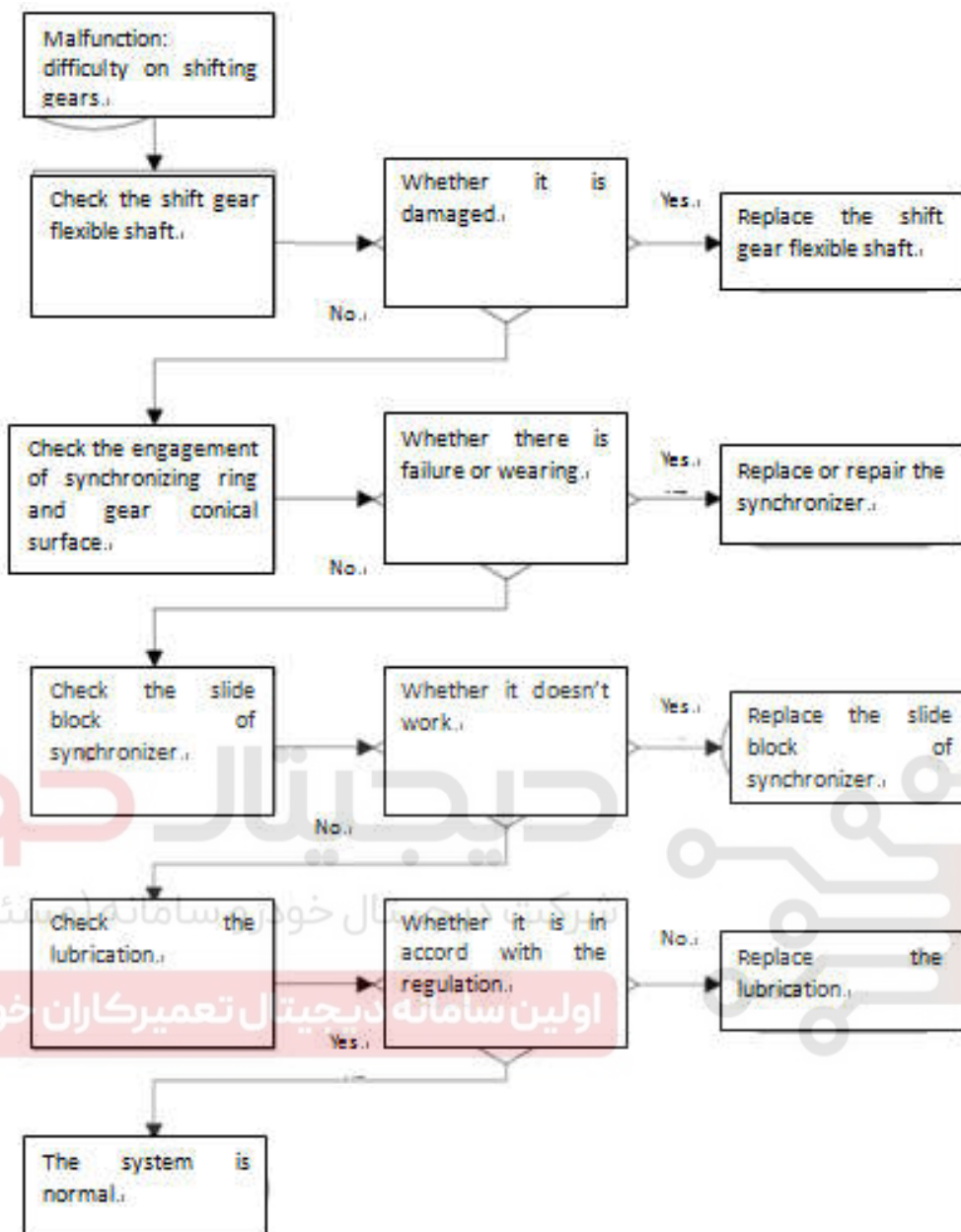

## 6MT Transmission

## III Draining and refueling of transmission oil

## ( I ) Special tools

## ( II ) Draining and refueling

## 1. Prepare work

- 1). Put the vehicle horizontally, and then pull up the hand brake.
- 2). Wait for the transmission oil to cool down.

## 2. Drain the transmission gear oil

- 1). Dismount transmission drain plug.
- 2). Drain off all transmission gear oil.
- 3). Check if there is scrap iron on the surface of the drain oil plug. If there is some, wipe them off timely.

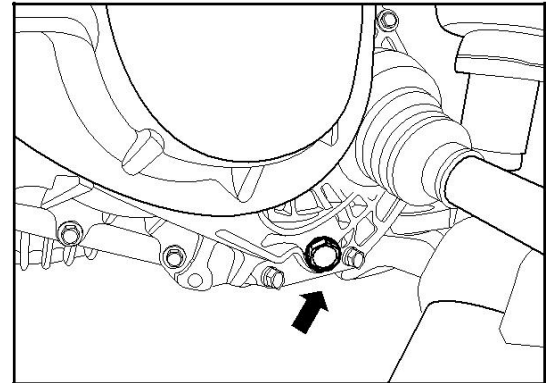

## 3. Refuel the transmission gear oil

- 1). Dismount filling plug
- 2). Keep refueling new gear oil until the oil lever comes near to the maximum location of filler.

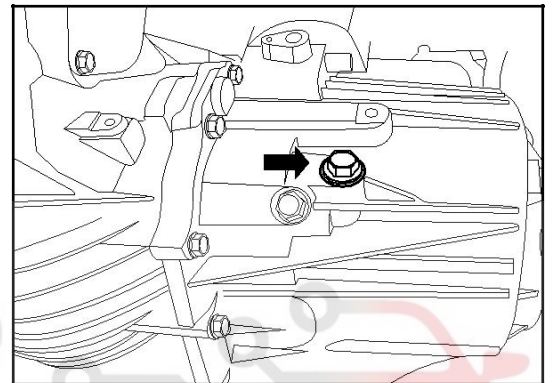

## 4. Check the transmission oil lever

- 1). Confirm that if there is gear oil leakage in manual transmission or around it.
- 2). Dismount the filler plug.

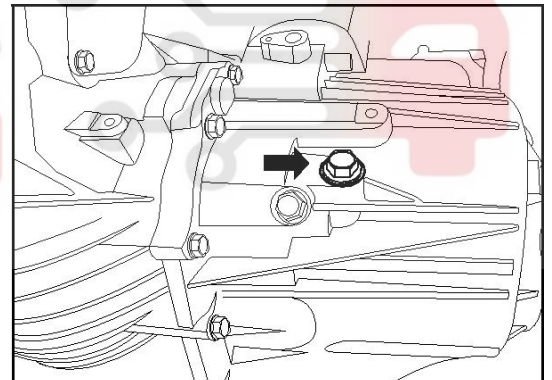

3). Check that if the transmission gear oil lever is as high as lower margin of filler.

4). If the transmission gear oil lever is lower than the lower margin of filler, please refuel specified MT gear oil from the filler till the oil begins to outflow.

5). Tightening filler plug.

△Notice: Check if the transmission gear oil deteriorated. If it's true, please change the gear oil.

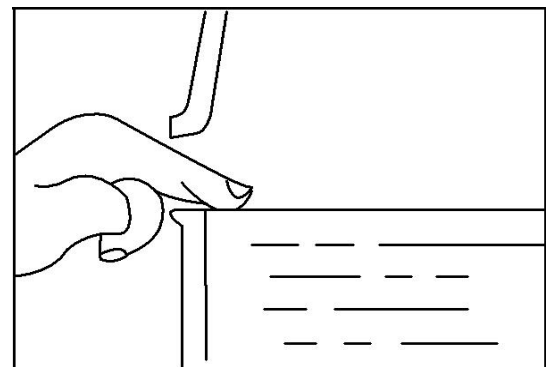

## 6MT Transmission

## IV Select and shift gear flexible shaft assembly

## ( I ) Special tools (Null)

## ( II ) Dismount

1. Dismount batteries (Refer to chapter battery)
2. Dismount air filter assy (Refer to air filter assy)
3. Dismount auxiliary dash board (Refer to auxiliary dash board)
4. Dismount select and shift gear flexible shaft

1). Dismount the lock pin and spring lock of lateral select and shift gear flexible shaft of transmission.

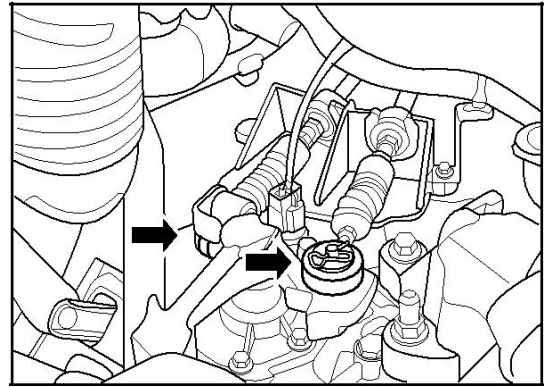

2). Take off the select and shift gear flexible shaft fixed sleeve from the transmission bracket.

△Notice: Just pull up the select and shift gear levers' flexible shafts; the black fixed sleeve was mounted on the stay wire as a unit.

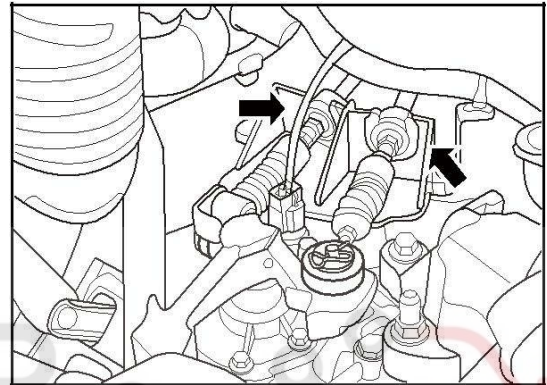

3). Cut off the connection between select gear flexible shaft and shift gear control mechanism.

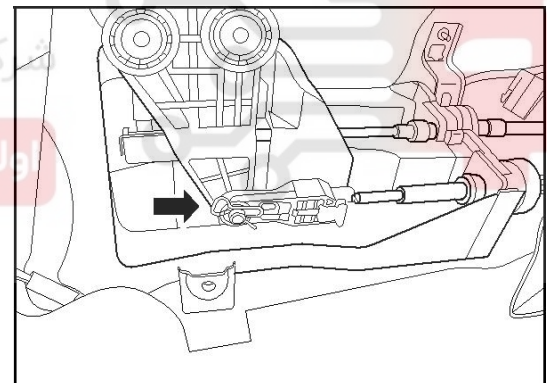

4). Cut off the connection between shift gear flexible shaft and shift gear control mechanism.

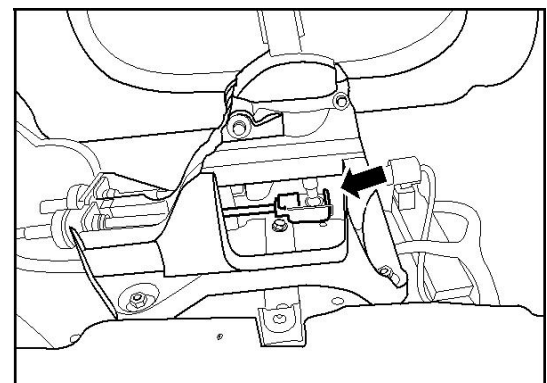

## 6MT Transmission

5). Take off the lateral select and shift gear flexible shaft fixed sleeve of control mechanism.

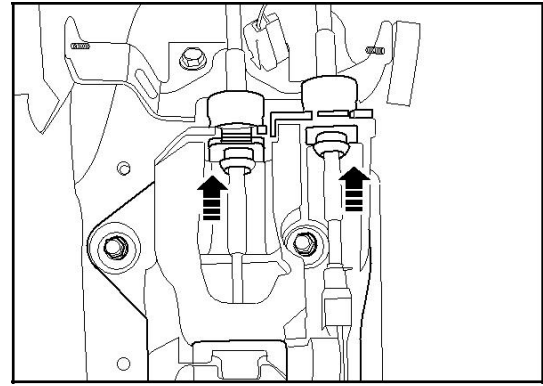

6). Dismount the select and shift gear wire drawing fixed bolt on the side of engine front plate.

7). Remove the select and shift flexible shaft assembly.

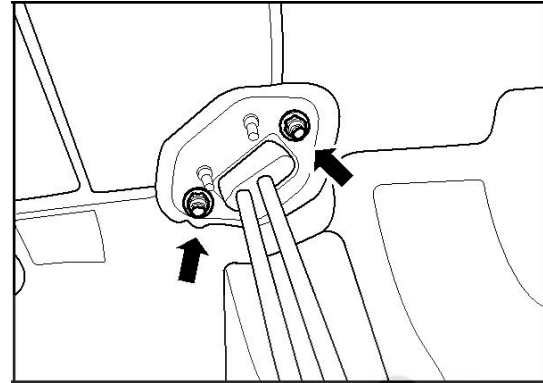

## (III) Mounting

1. Mount the select and shift gear flexible shaft

1). Connect the select gear flexible shaft on the control mechanism.

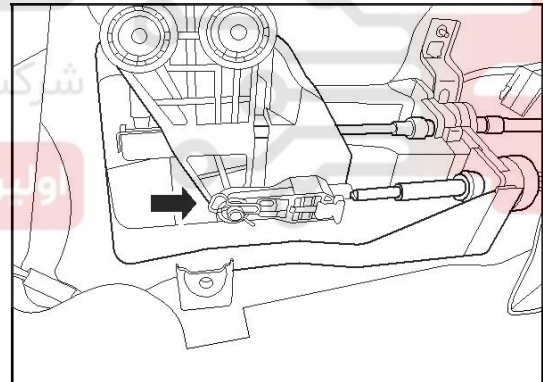

2). Connect the shift gear flexible shaft on the control mechanism.

3). Fix the select and shift gear fixed sleeve.

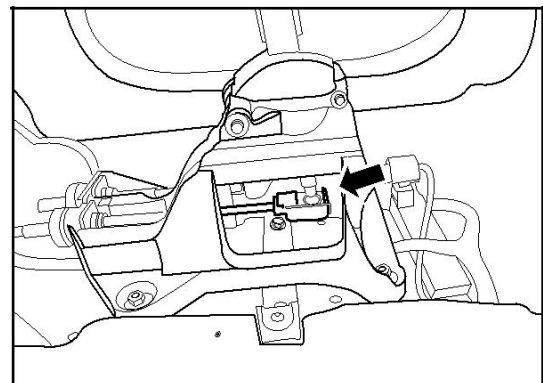

4). Connect the select and shift gear flexible shaft on the transmission shift gear control mechanism.

△Notice: Mount the select and shift gear wire drawing correctly.

## 6MT Transmission

3). Fix the select and shift gear fixed sleeve.

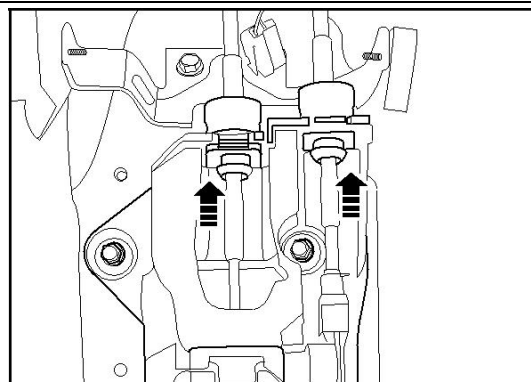

4). Connect the select and shift gear flexible shaft on the transmission shift gear control mechanism.

△Notice: Mount the select and shift gear wire drawing correctly.

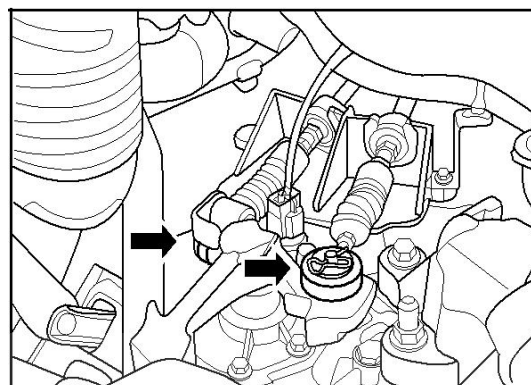

△Notice: Mounting direction of spring lock.

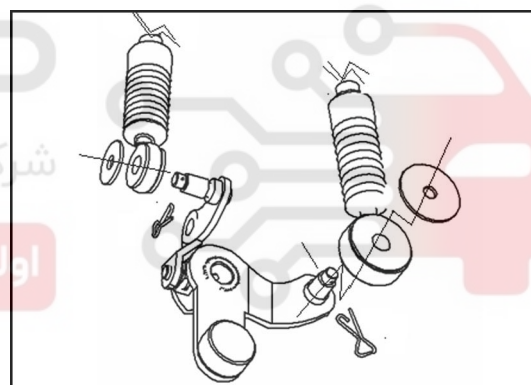

5). Mount U-type snap-gauge; fix the select and shift gear flexible shaft on the bracket of transmission.

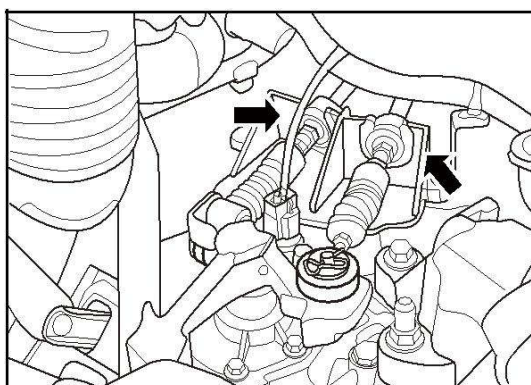

## 6MT Transmission

6). Mount the select and shift gear wire drawing fixed bolt on the side of engine front plate.

Tightening torque: 20~30N·m.

2. Check if the parts mounted correctly
  - 1). Put the select gear lever on the side of 1<sup>st</sup> to 2<sup>nd</sup> gears and 5<sup>th</sup> to 6<sup>th</sup> gear, make sure the select gear lever can smoothly shift into the natural.
  - 2). When the lever shift into every gear, please make sure it goes smoothly.
3. Mount auxiliary dash board
4. Mount air filter assembly

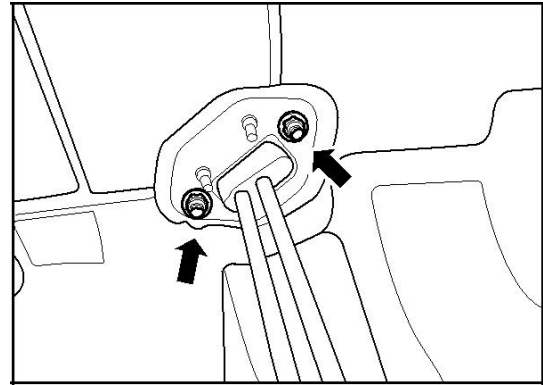

## V Operation mechanism with lever assembly

### ( I ) Special tools (null)

### ( II ) Dismount

1. Dismount auxiliary dash board (Refer to Chapter Dash board)
2. Cut off the select and shift gear flexible shaft (Refer to Chapter Select and shift gear flexible shaft assembly)
3. Dismount operation mechanism with lever assembly
  - 1). Dismount the fixed bolt of the select and shift gear operation mechanism.

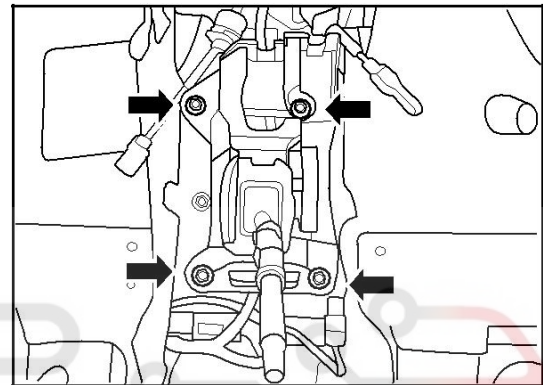

2). Remove the operation mechanism with lever assembly.

### ( III ) Mounting

1. Mount the operation mechanism with lever assembly
    - 1). Mount the operation mechanism with lever assembly on the vehicle.
    - 2). Tighten the 4 fixed bolts.
- Tightening torque: 20~30 N·m
2. Mount auxiliary dash board
  3. Mount air filter assembly

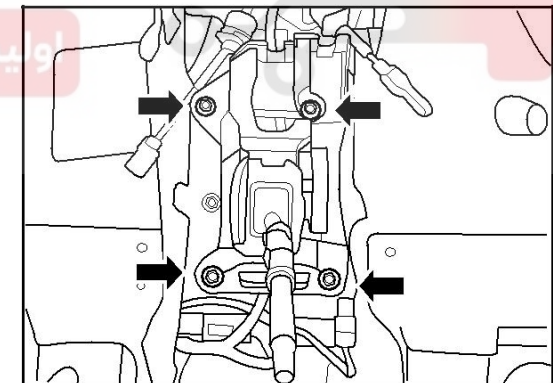

## VI Select and shift gear base assembly

### ( I ) Special tools (null)

### ( II ) Dismounting

1. Dismount air filter assembly (Refer to chapter air filter assy)

6MT Transmission

2. Dismount the select and shift gear base assembly
  - 1). Dismount the 5 fixed bolts of the select and shift gear base assembly
  - 2). Put the transmission in neutral, then pull up the select and shift gear arm fitting.

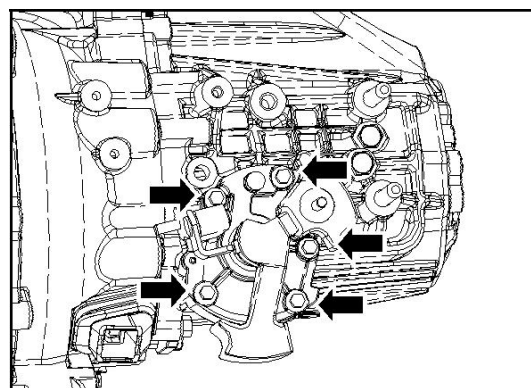

(III) Mounting

1. Mount Select and shift gear base assembly.
  - 1). Put the transmission in neutral, then mount the select and shift gear arm fitting.
  - 2). Mount the 5 fixed bolts of the select and shift gear base assembly, and tighten them.

Tightening torque: 25~30N·m

2. Mount air filter assembly

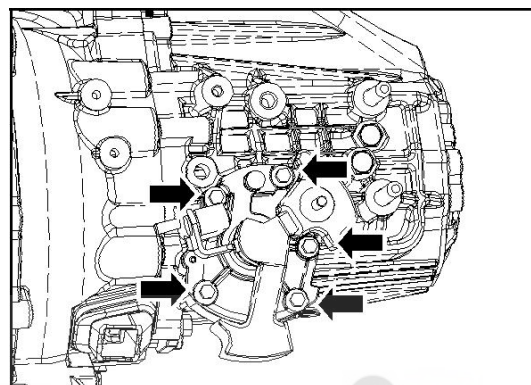

VII Transmission assembly

( I ) Special tools

No.	Tool number	Tool name	Diagram
1	27G0061	Backup light switch sleeve	

( II ) Dismounting

1. Drain the transmission gear oil
2. Dismount batteries (Refer to Chapter Battery)
3. Dismount air filter assembly (Refer to Chapter Air filter assembly)
4. Dismount starter (Refer to Chapter Starter)
5. Dismount front driving shaft (Refer to Chapter Front driving shaft)

△Notice: After dismounting the front driving shaft, please put a suitable plug in the side oil seal to avoid impurities into the transmission.

6. Dismount engine guide plate (Refer to Chapter Engine guide plate)
7. Dismount the transmission assembly
  - 1). Dismount batteries pallet
  - 2). Cut off the harness connector of backup light switch.

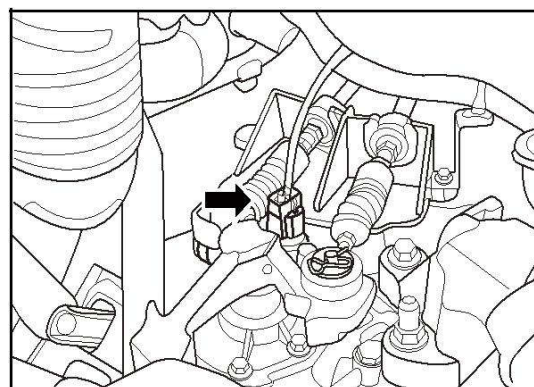



## 6MT Transmission

- 3). Cut off the transmission select and shift gear flexible shaft.
- 4). Mount hanging bracket on engine lifting hook.

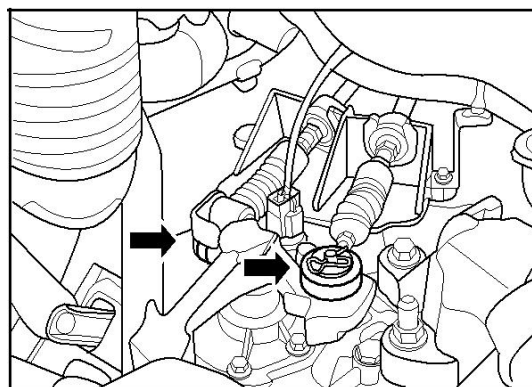

- 5). Dismount the fixing bracket of clutch oil pipe.

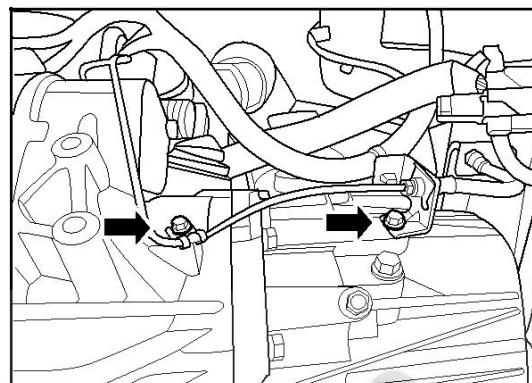

- 6). Dismount clutch wheel cylinder fixed bolts; cut off the clutch wheel cylinder from transmission.

- 7). Use jack lever to lift the transmission assembly.

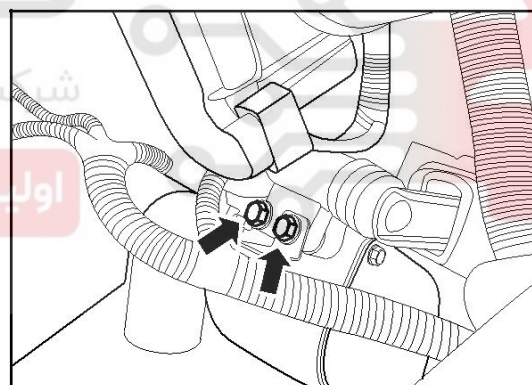

- 8). Dismount transmission lower clapboard.

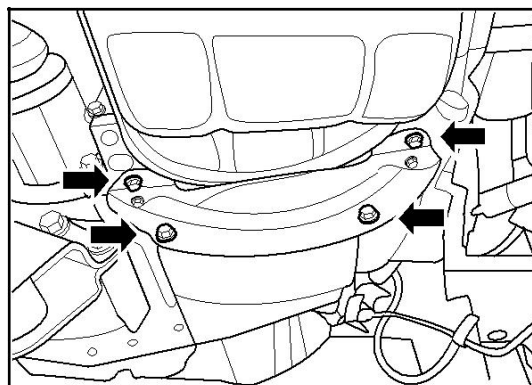

**6MT Transmission**

9). Dismount three fixed bolts on transmission and upper side of engine.

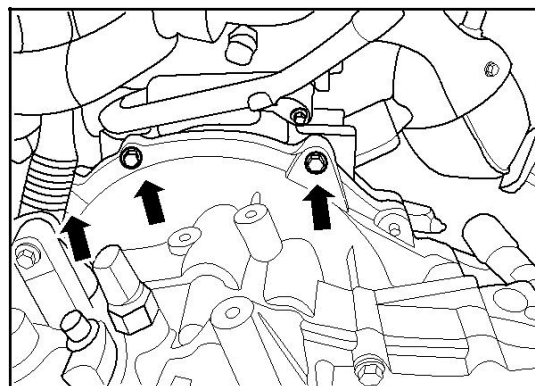

10). Dismount fixed bolts in the middle of transmission and engine.

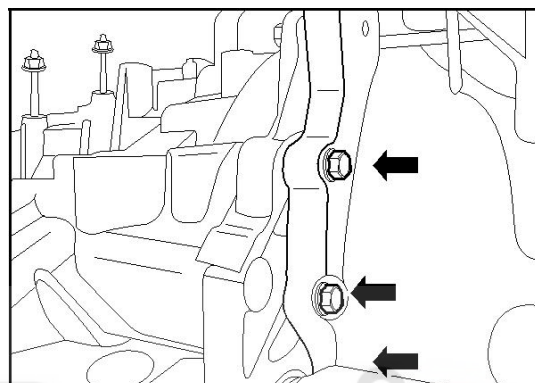

11). Dismount transmission rear suspension.

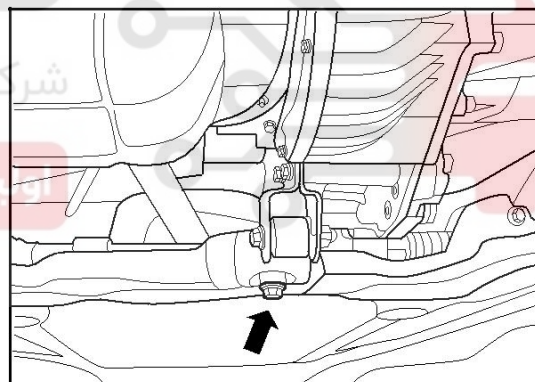

12). Dismount the transmission left suspension fixing bracket.

13). Pull down the jack lever; remove the transmission assy from vehicle.

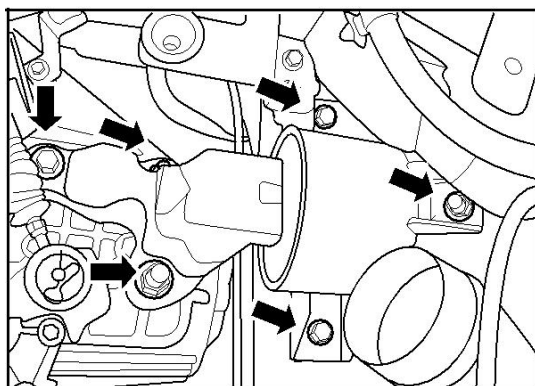

## 6MT Transmission

## (III) Mounting

1. Mount transmission assembly
  - 1). Mount the transmission on the vehicle.
  - 2). Mount the transmission left suspension.
  - 3). Mount and tighten the 3 connecting bolts between left suspension and vehicle body.

Tightening torque: 50~60N·m

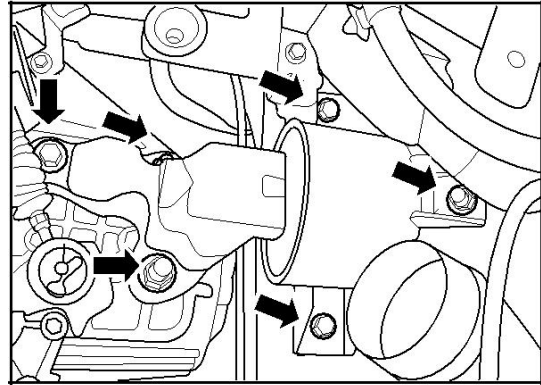

- 4). Mount transmission rear suspension.
- 5). Tighten the connecting bolts between rear suspension and sub-frame.

Tightening torque: 115~145N·m

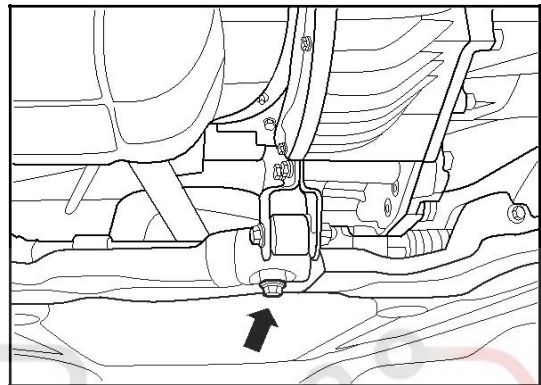

- 6). Mount fixed bolts in the middle of transmission and engine.

Tightening torque: 34.3~41.2N·m

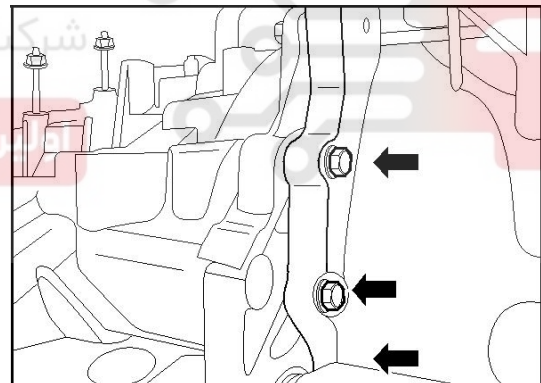

- 7). Mount and tighten the three fixed bolts on transmission and upper side of engine.

Tightening torque: 34.3~41.2N·m

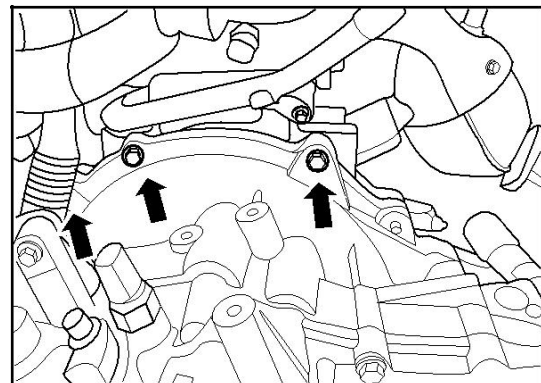

**6MT Transmission**

8). Mount transmission lower clapboard and tighten the fixed bolts.

Tightening torque: 8~12N·m

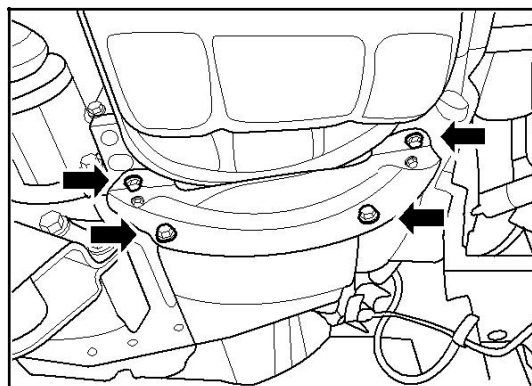

9). Connect the clutch wheel cylinder and tighten the fixed bolts.

Tightening torque: 20N·m

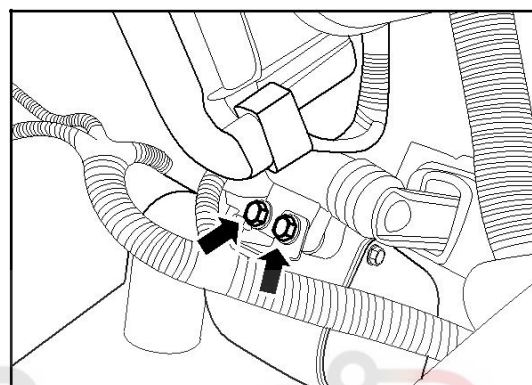

10). Connect the shift gear flexible shaft.

11). Connect the reverse gear switch harness connection.

2. Mount engine guide plate
3. Mount front driving shaft
4. Mount the starter
5. Mount air filter assembly
6. Mount batteries
7. Refuel transmission gear oil

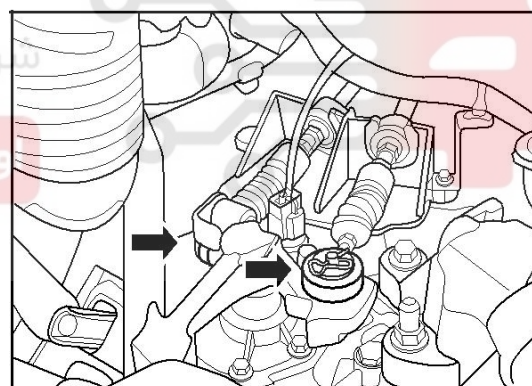

## 6MT Transmission

## VIII Release bearing and shifting fork assembly

## ( I ) Special tools (null)

## ( II ) Dismounting

1. Dismount transmission assembly Refer to chapter transmission assembly)
2. Remove release bearing and shifting fork assembly
  - 1). Remove the release bearing.

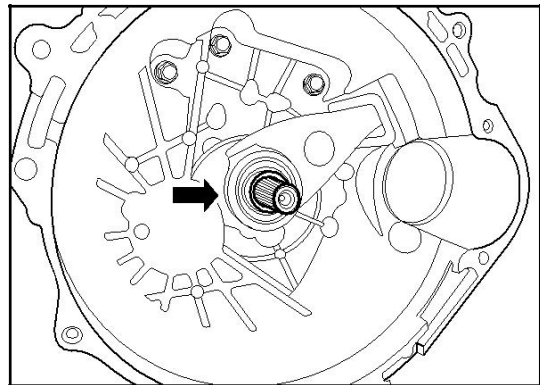

- 2). Exert strengths to break the release shifting fork snap spring away from support point, then remove the release shifting fork.

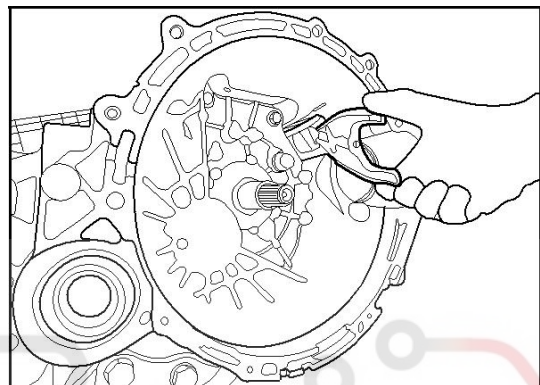

## (III) Mounting

1. Mount release bearing and shifting fork assembly
  - 1). Mount the release shifting fork snap spring on its right position.

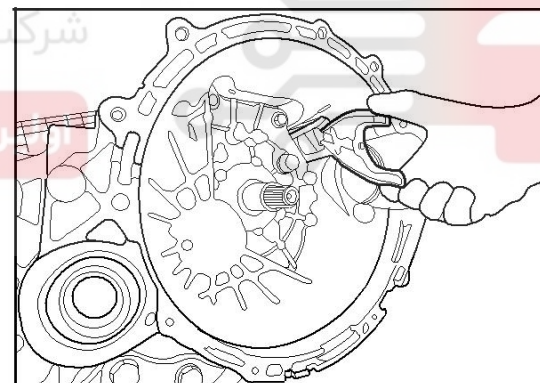

- 2). Mount well the release bearing and shifting fork at the same time.

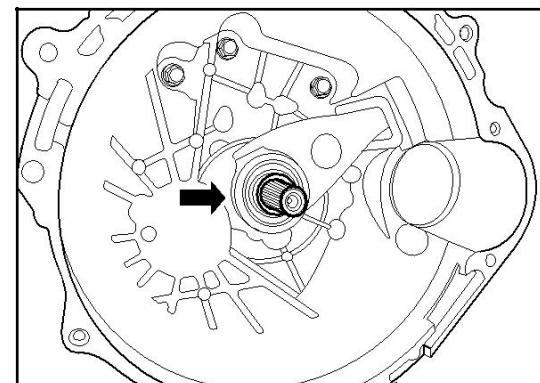

## IX Rear housing

( I ) Special tools (null)

( II ) Dismounting

1. Dismount transmission assembly ( Refer to chapter transmission assembly)
2. Dismount reverse switch assembly (Refer to chapter reverse switch assembly)
3. Dismount select and shift gear base assembly (Refer to chapter select and shift gear base assembly)
4. Dismount the release bearing and shifting fork assembly (Refer to chapter release bearing and shifting fork assembly)
5. Dismount rear housing
  - 1). Dismount the reverse gear shaft bolts directly with wrench.

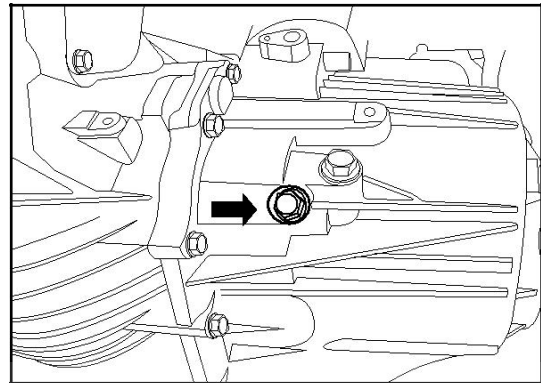

- 2). Dismount three self-lock pin fittings.

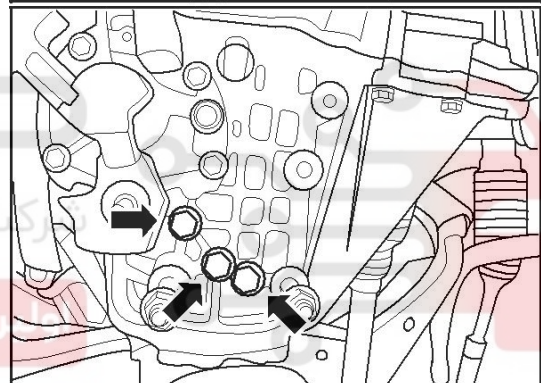

- 3). Dismount the 12 fixed bolts outside.

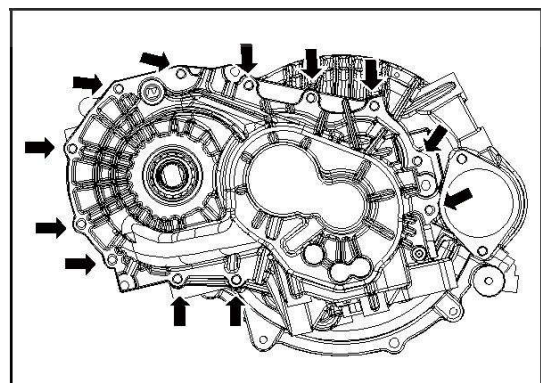

- 4). Dismount the 3 fixed bolts inside.

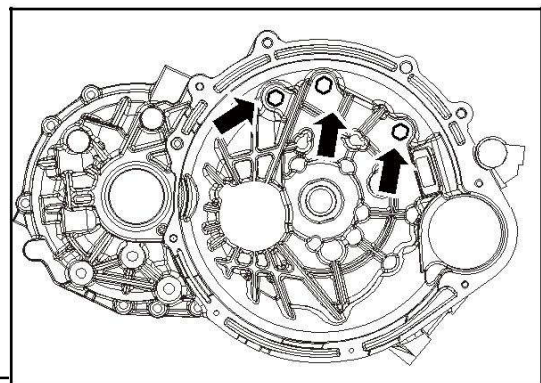

## 6MT Transmission

5). Use copper bar to slightly smash the clutch housing to make the clutch housing and junction surface of shell separated.

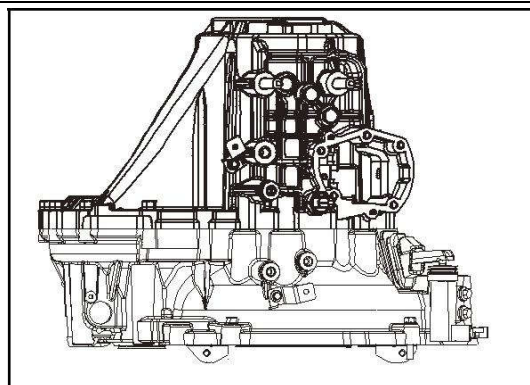

## (III) Mounting

## 1. Mount rear housing

1). Align the locating pin, and then mount the transmission rear housing on the clutch shell.

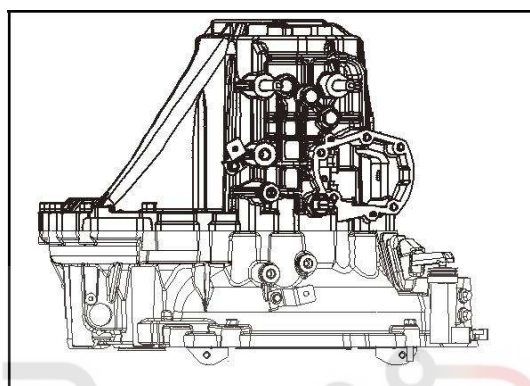

2). Pre-smear thread locking adhesives on bolts; tighten the 3 fixed bolts inside.

Tightening torque: 34.3~41.2N·m

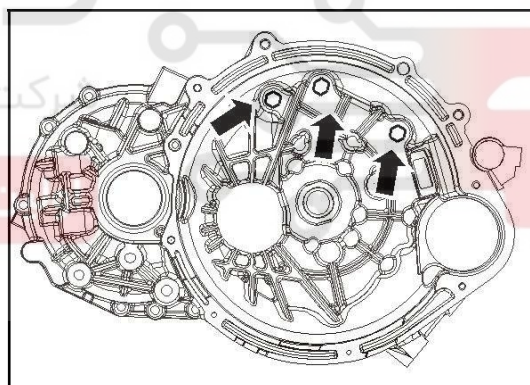

3). Pre-smear thread locking adhesives on bolts; tighten the 12 fixed bolts outside.

Tightening torque: 34.3~41.2N·m

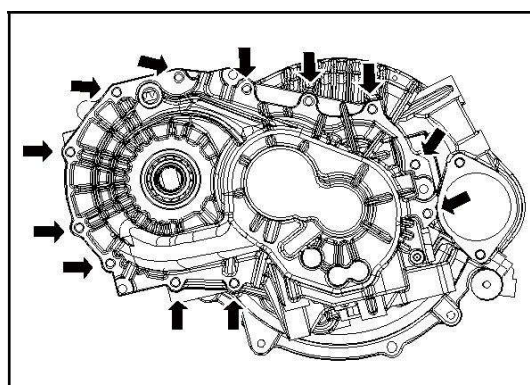

## 6MT Transmission

4). Mount three self-lock pin fittings.

Tightening torque: 30~40N·m

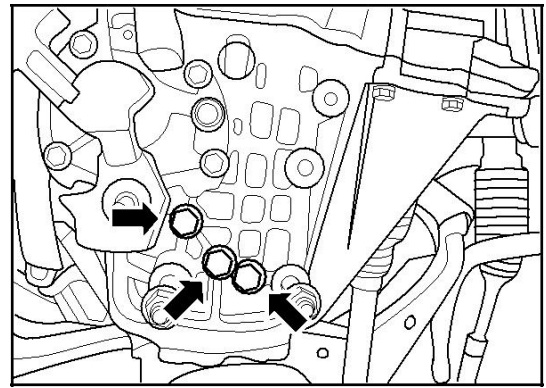

5). Mount the reverse gear shaft bolts directly with wrench.

2. Mount the release bearing and shifting fork assembly
3. Mount select and shift gear base assembly
4. Mount reverse switch assembly
5. Mount transmission assembly

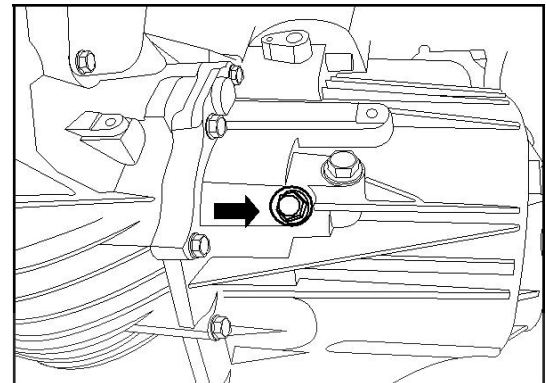

## X Reverse gear intermediate shaft assembly

### ( I ) Special tools ( null )

### ( II ) Dismounting

1. Dismount transmission assembly (Refer to Chapter Transmission assembly)
2. Dismount reverse switch assembly (Refer to Chapter Reverse switch assembly)
3. Dismount select and shift gear base assembly (Refer to Chapter Select and shift gear base assembly)
4. Dismount the release bearing and shifting fork assembly (Refer to Chapter Release bearing and shifting fork assembly)
5. Dismount rear housing (Refer to Chapter Rear housing)
6. Dismount reverse gear intermediate shaft assembly

1). Pull up reverse gear intermediate shaft in axial direction, then the reverse gear shaft fitting can be removed.

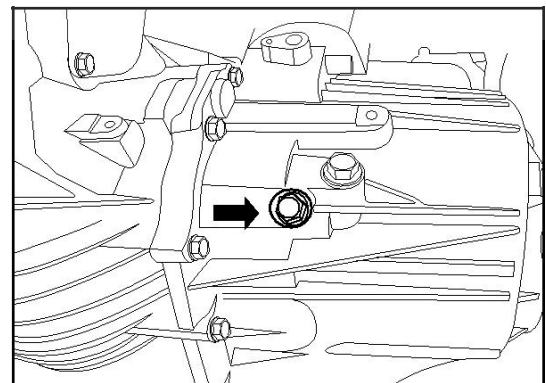

### ( III ) Mounting

1. Mount reverse gear intermediate shaft
  - 1). Mount the reverse gear shaft fitting in the mounting hole.
  - 2). Rotate reverse gear tooth to see if it rotates smoothly.
2. Mount rear housing
3. Mount the release bearing and shifting fork assembly
4. Mount select and shift gear base assembly
5. Mount reverse switch assembly
6. Mount transmission assembly

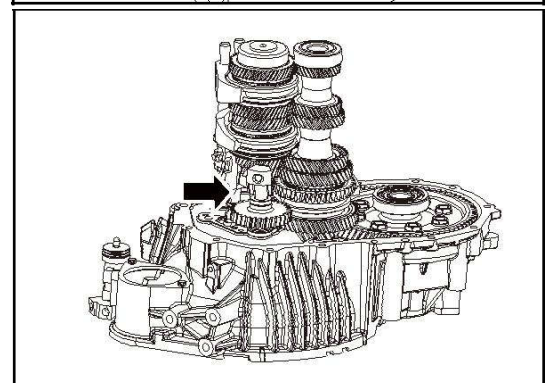



## XI Select and shift gear fork and shifting fork shaft

### ( I ) Special tools ( null )

### ( II ) Dismounting

1. Dismount transmission assembly (Refer to Chapter Transmission assembly)
2. Dismount reverse switch assembly (Refer to Chapter Reverse switch assembly)
3. Dismount select and shift gear base assembly (Refer to Chapter Select and shift gear base assembly)
4. Dismount the release bearing and shifting fork assembly (Refer to Chapter Release bearing and shifting fork assembly)
5. Dismount rear housing (Refer to Chapter Rear housing)
6. Dismount reverse gear intermediate shaft assembly (Refer to Chapter Reverse gear intermediate shaft assembly)
7. Dismount select and shift gear fork and shifting fork shaft
  - 1). Remove the two bolts on support base, and then pull them up to take off the shift gear shaft support base.
  - 2). Remove three resilient pins connecting the shifting fork with fork shaft; pull up the fork shaft and then take off the fork, fork shaft and fork block.

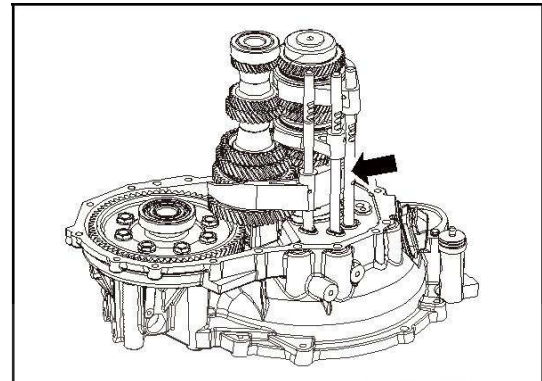

### ( III ) Mounting

1. Mount select and shift gear fork and shifting fork shaft
    - 1). Mount the fork, fork shaft and fork block on input and output shafts.
    - 2). Mount resilient pins.
    - 3). Mount the shift gear shaft support base, and then tighten the 2 fixed bolts.
- Tightening torque : 15~22N·m

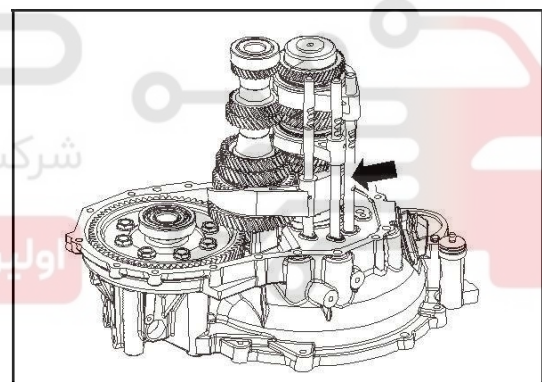

2. Mount reverse gear intermediate shaft
3. Mount rear housing
4. Mount the release bearing and shifting fork assembly
5. Mount select and shift gear base assembly
6. Mount reverse switch assembly
7. Mount transmission assembly

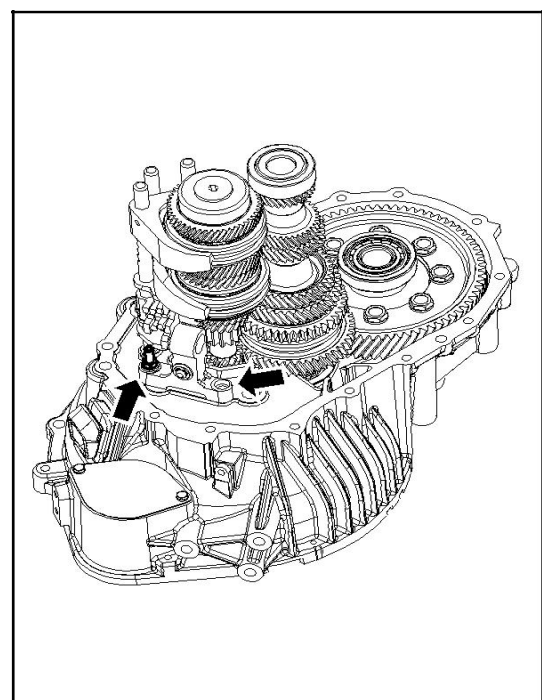

## 6MT Transmission

## XII Input and output shaft assembly

## ( I ) Special tools

No.	Tool number	Tool name	Diagram	Function
1	27G0060	Compacter of fork shaft fixed pin		Dismount fork shaft fixed pin
2	27G0062	Mounting tool of input shaft oil seal		Mount input shaft oil seal
3	27G0065	Mount and dismount heel block of input shaft		Mount and dismount input shaft bearing and synchronizer
4	27G0066	Mounting tool of input shaft 6th gear sleeve		1.mount input shaft 6th gear sleeve 2.mount input shaft rear end bearing 3. mount output shaft end bearing
5	27G0067	Mounting tool of 4th and 5th gear sleeve		Mount 4th and 5th gear sleeve
6	27G0068	Mounting tool of input shaft front bearing		Mount input shaft front bearing
7	27G0069	Mounting tool of output shaft front bearing outer ring		Mount output shaft front bearing outer ring
8	27G0070	Mounting tool of output shaft rear bearing outer ring		Mount output shaft rear bearing outer ring
9	27G0071	Mounting tool of differential bearing outer ring		Mount differential bearing outer ring

**6MT Transmission**

10	27G0072	Mounting tool of select gear shaft oil seal		Mount select gear shaft oil seal
11	27G0073	Mounting tool of select gear shaft linear bearing		Mount select gear shaft linear bearing
12	27G0074	Mount and dismount heel block of output shaft		Mount and dismount output shaft gear and synchronizer
13	27G0075	Dismounting tool of 4th,5th and 6th gear		Dismount 4th,5th and 6th gear
14	27G0076	Dismounting tool of 3rd gear		Dismount 3rd gear
15	27G0077	Mounting tool of output shaft gear		Mount 3rd,4th,5th and 6th gear
16	27G0078	Mounting tool of output shaft 1st gear synchronizer		Mount output shaft 1st gear synchronizer

**( II ) Dismounting**

1. Dismount transmission assembly (Refer to Chapter Transmission assembly)
2. Dismount reverse switch assembly (Refer to Chapter Reverse switch assembly)
3. Dismount select and shift gear base assembly (Refer to Chapter Select and shift gear base assembly)
4. Dismount the release bearing and shifting fork assembly (Refer to Chapter Release bearing and shifting fork assembly)
5. Dismount rear housing (Refer to Chapter Rear housing)
6. Dismount reverse gear intermediate shaft assembly (Refer to Chapter Reverse gear intermediate shaft assembly)
7. Dismount select and shift gear fork and shifting fork shaft (Refer to Chapter Select and shift gear fork and shifting fork shaft)
8. Dismount input and output shaft
  - 1). Take off the pressure plate by removing the 4 screws.
  - 2). Pull upward the input and output shaft at the same time.

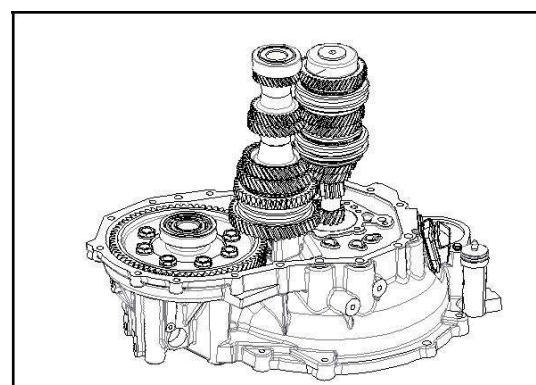

## 6MT Transmission

## (III) Disassembling

1. Disassemble input shaft assy.

1). Put the input shaft vertically on the working table.

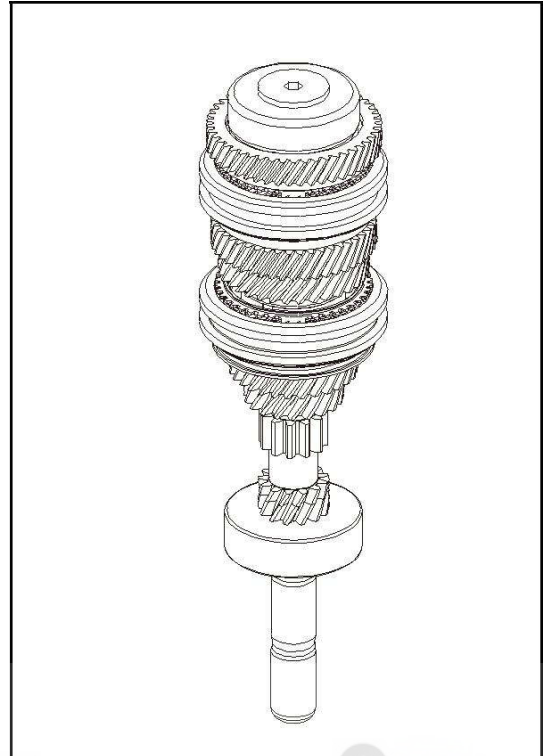

4). Remove the input 6<sup>th</sup> gear sleeve with special tool.

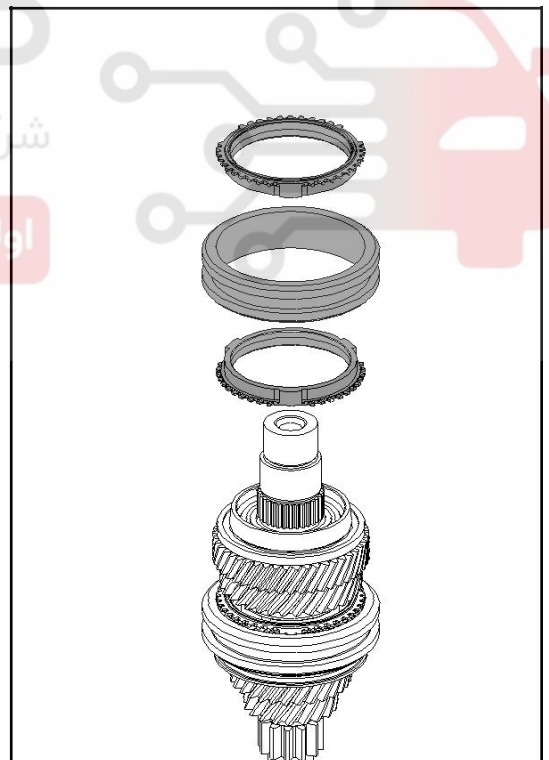

**6MT Transmission**

5). Remove the 5/6<sup>th</sup> gear synchronizer assy and 5/6<sup>th</sup> gear synchronizing ring together.

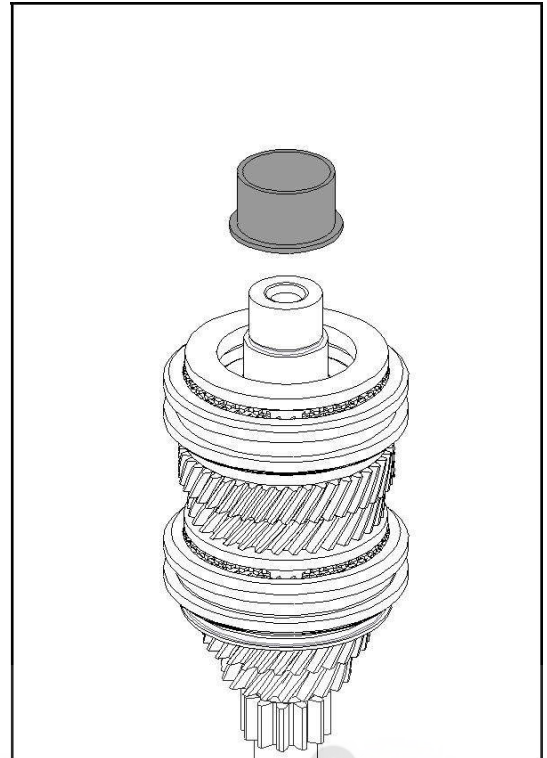

6). Take down the input 5<sup>th</sup> gear fitting and 5<sup>th</sup> gear needle bearing.

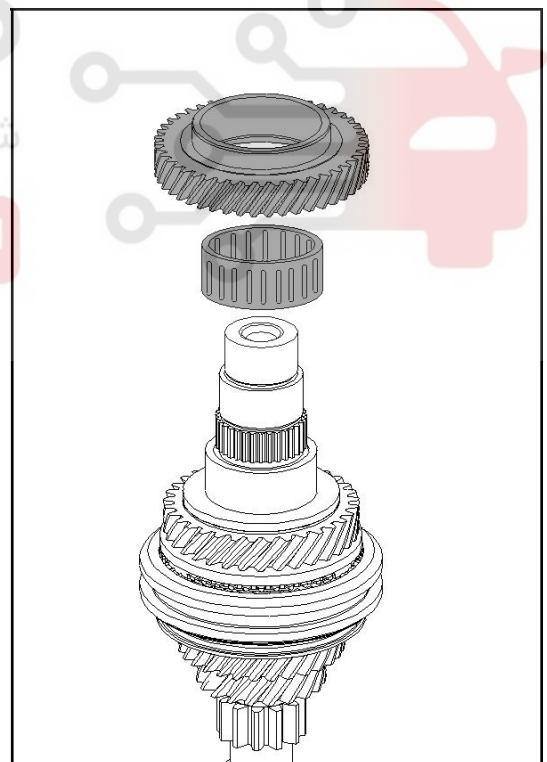

دیجیتال خودرو  
شرکت دیجیتال خودرو سامانه (مسئولیت محدود)  
اولین سامانه دیجیتال تعمیرکاران خودرو در ایران

## 6MT Transmission

7). Take down the 5<sup>th</sup> gear sleeve with special tool, and then take down the input 4<sup>th</sup> gear fitting and its needle bearing.

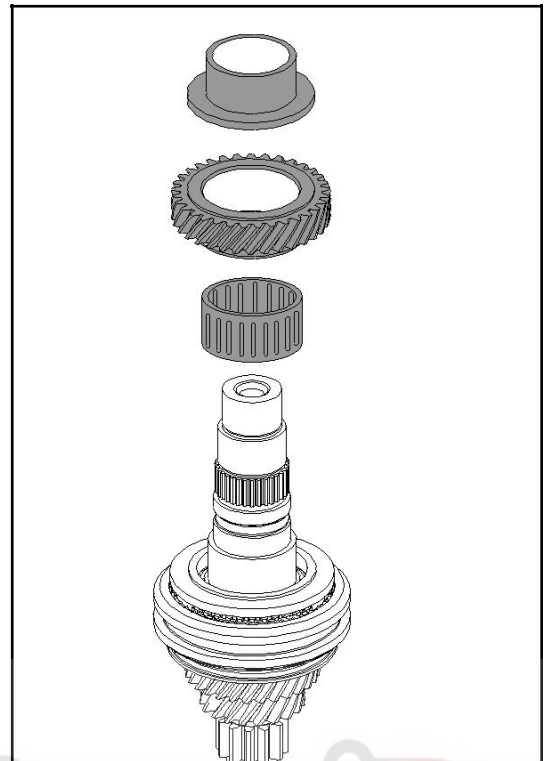

8). Hook the lower end of input 3<sup>rd</sup> gear tooth fitting, and then pull down input 4<sup>th</sup> gear sleeve, 3/4<sup>th</sup> gear synchronizer assy and input 3<sup>rd</sup> gear tooth fitting together to take off the 3<sup>rd</sup> gear needle bearing.

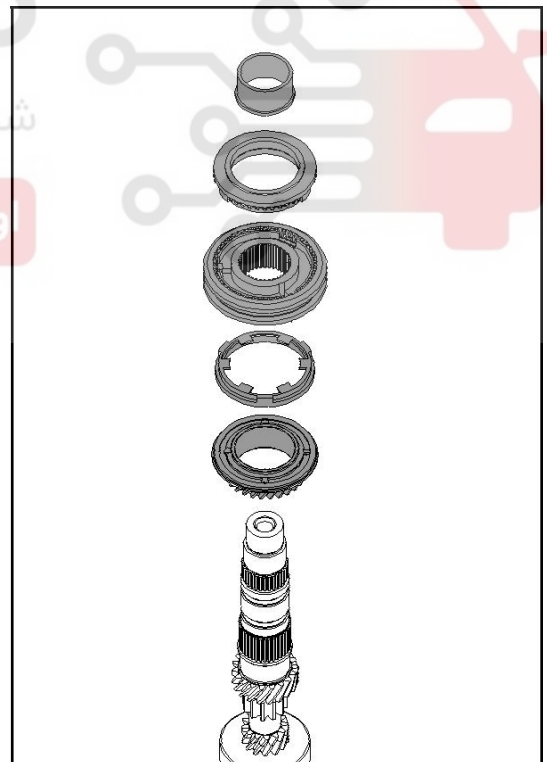

**6MT Transmission**

9). Dismount input shaft front bearing.

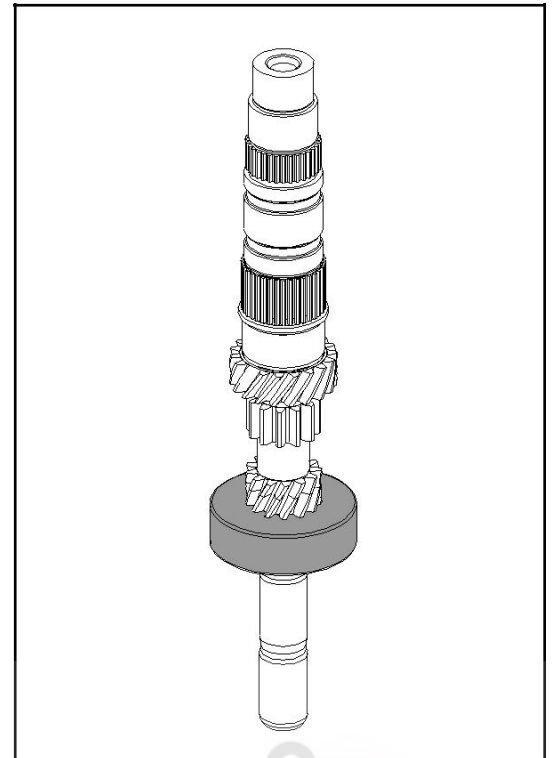

2. Disassemble the output shaft

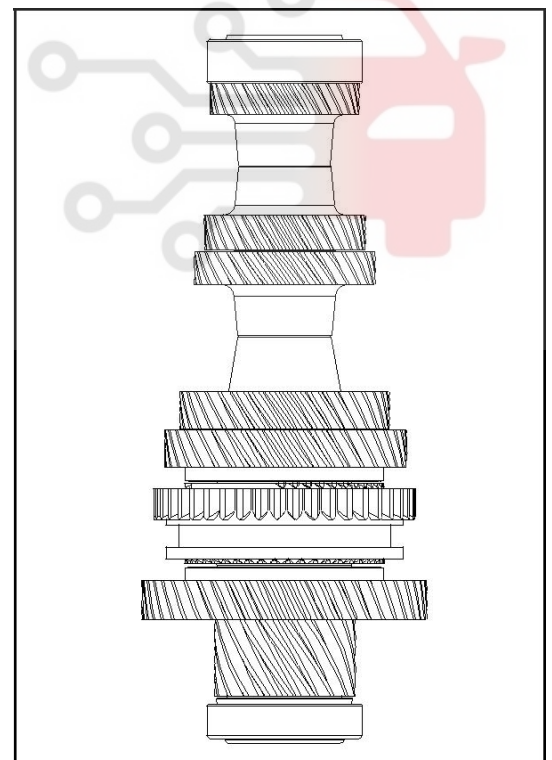

1). Put the output shaft vertically on the working table.

دیجیتال خودرو  
شرکت دیجیتال خودرو سامانه (تولیدی محدود)

اولین سامانه دیجیتال تعمیرکاران خودرو در ایران

**6MT Transmission**

2). Remove the adjusting shim. (Output shaft rear bearing)

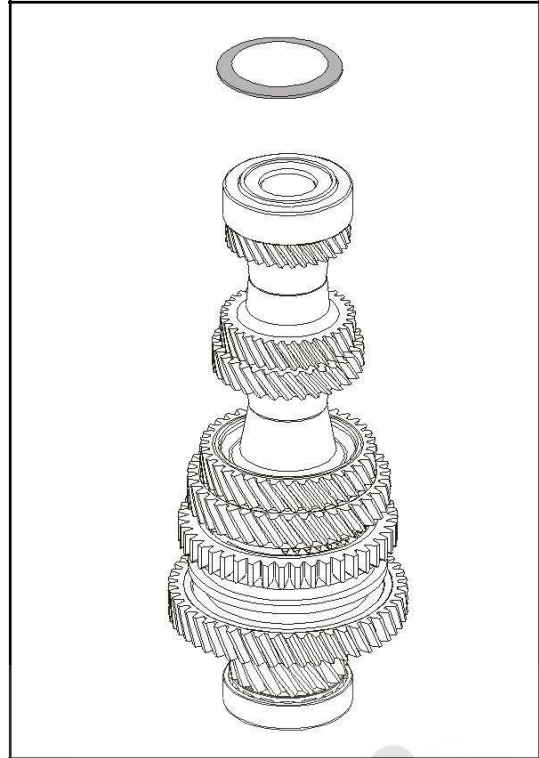

3). Dismount the output 6<sup>th</sup> gear and output shaft rear bearing together.

△Notice: Hook the lower end of output 6<sup>th</sup> gear with special tool, and then pull down the 6<sup>th</sup> gear and bearing together.

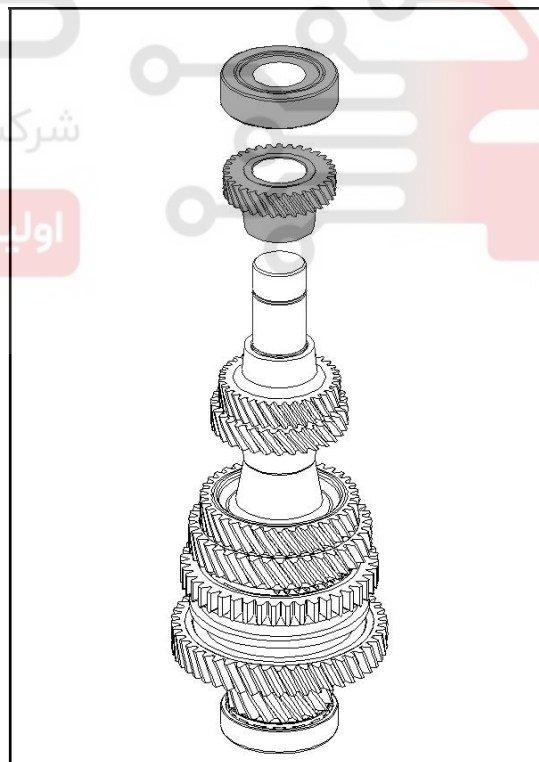



## 6MT Transmission

4). Hook the lower end of output 4<sup>th</sup> gear with special tool, and then pull down the 5<sup>th</sup> gear and 4<sup>th</sup> gear together.

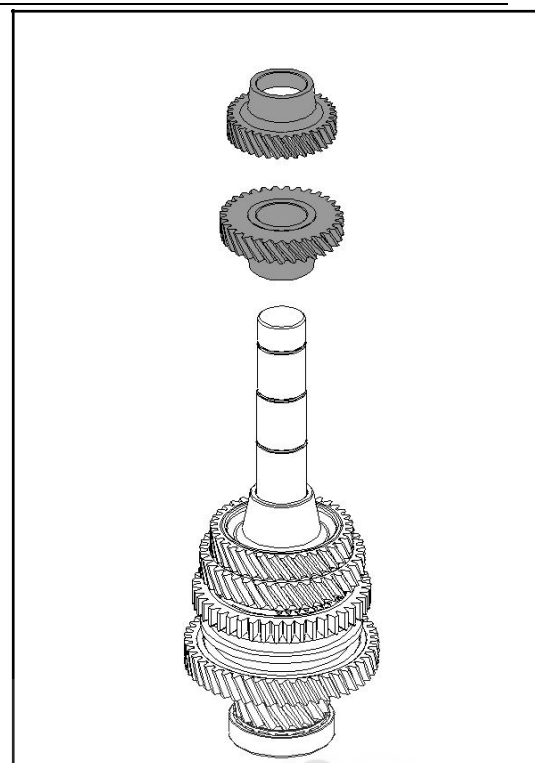

5). Hook the lower end of output 2<sup>nd</sup> gear fitting with special tool, and then pull down the 3<sup>rd</sup> gear and 2<sup>nd</sup> gear together, finally take down the 2<sup>nd</sup> needle bearing.

△Notice: Check if there is any damage of the needle bearing.

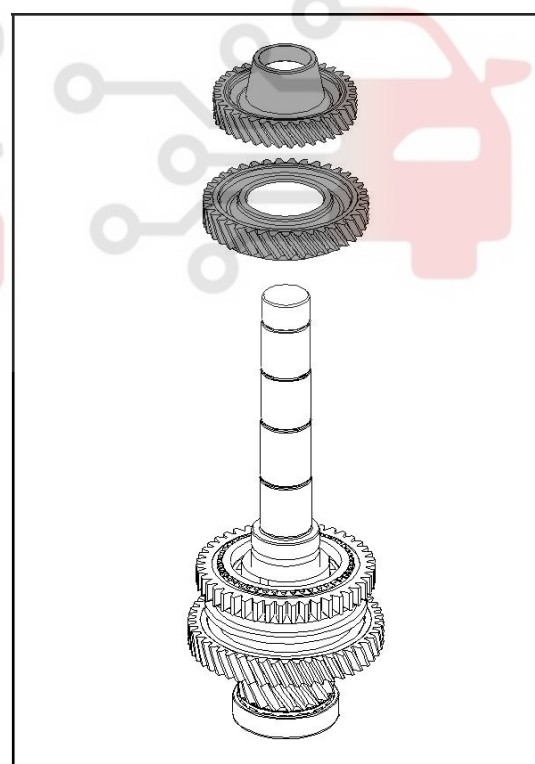

دیجیتال خودرو  
شرکت دیجیتال خودرو سامانه (مسئولیت محدود)  
اولین سامانه دیجیتال تعمیرکاران خودرو در ایران

## 6MT Transmission

6). Dismount the 1/2 gear synchronizer assy and 1/2 synchronizing ring together with special tool.

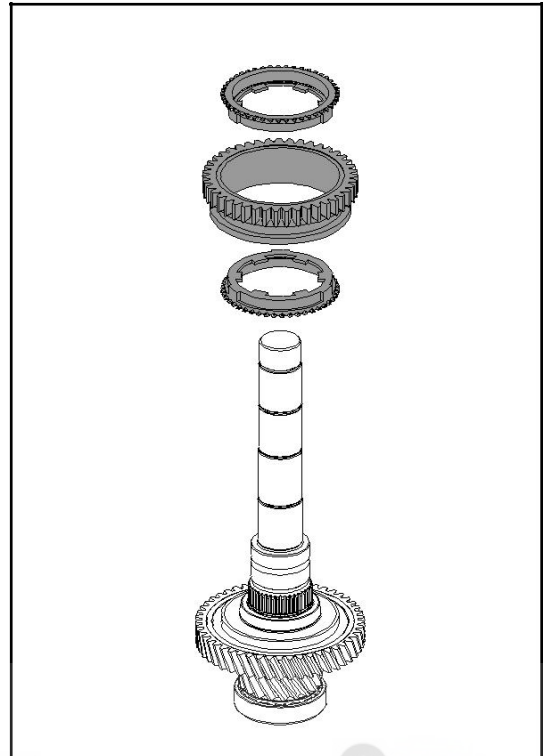

7). Dismount output 1<sup>st</sup> gear fitting and 1<sup>st</sup> gear bearing (please check if there is any damage of the needle bearing).

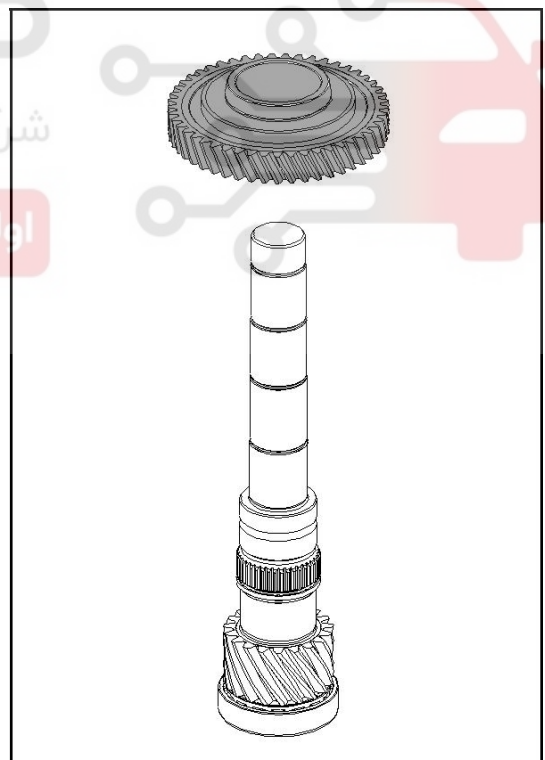

## (IV) Checking

## 1. Check the input shaft

1). Check the input shaft to see whether the gear is broken or the gear surface occurred pitting, wearing and agglutination. If these phenomena occurred, you must replace the input shaft.

2). Use your hands to "feel" whether the bearing rotates flexibly or occurred nimbleness. If these situations happened, you must replace the bearing.

## 2. Check the output shaft

## 6MT Transmission

1). Check the output shaft to see whether the gear is broken or the gear surface occurred pitting, wearing and agglutination. If these phenomena occurred, you must replace the output shaft.

2). Check whether the output shaft spline has severe wearing or damage. If there is any damage, you must replace the output shaft.

3). Use your hands to "feel" whether the bearing of output shaft front end rotates flexibly or occurred nimbleness. If these situations happened, you must replace the bearing.

3. Check (toothed) gear of every gear

1). Check to see whether gears of every gear are broken or the gear surface occurred pitting, wearing and agglutination. If these damages occurred, you must replace the corresponding gears.

4. Check the needle bearing of every gear

1). Check to see whether needle bearing of every gear occurred following phenomena including severe wearing; falling off of the needle bearing or incompleteness of the holder. If these damages occurred, you must replace the needle bearing.

5. Check the synchronizing ring

1). Check whether the surface of synchronizing ring has any damage or failure.

2). Check whether the cone surface has any damage or wearing and whether the thread has been crushed.

3). Synchronizing ring of 4<sup>th</sup>, 5<sup>th</sup> and 6<sup>th</sup> is single-cone ring. Check the clearance "A" while pushing the synchronizing ring towards the gear. If "A" is less than the minimum, then please replace the synchronizing ring.

Minimum: A=0.5mm

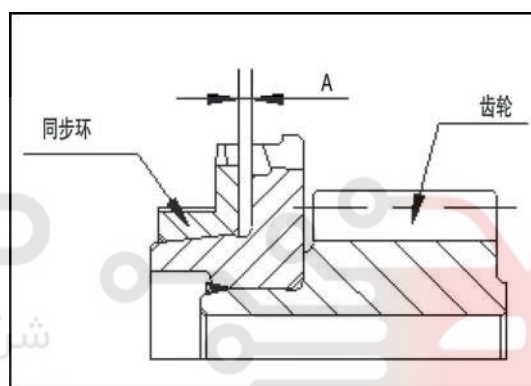

4). Synchronizing ring of 1<sup>st</sup>, 2<sup>nd</sup> and 3<sup>rd</sup> is tri-cone ring. Check the clearance "B, C" while pushing the synchronizing ring towards the gear. If "B, C" is less than the minimum, then please replace the synchronizing ring.

Minimum: "B"=0.5mm "C"=0.5mm

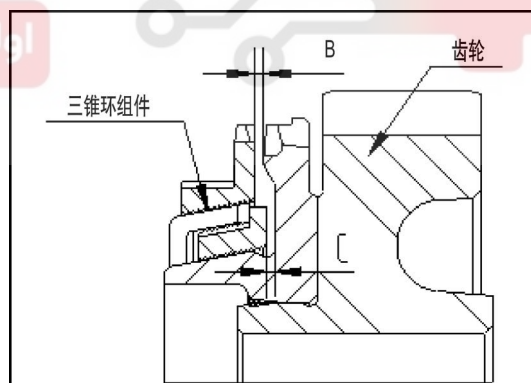

6. Check the synchronizer

1). Assemble the gear sleeve and hub of synchronizer together, and check to see if they can slide smoothly or has any nimbleness.

2). Check if there is any damage on two ends of gear sleeve's internal surface.

△Notice: If you need to replace the synchronizer for nimbleness or damage, please replace with a whole set.

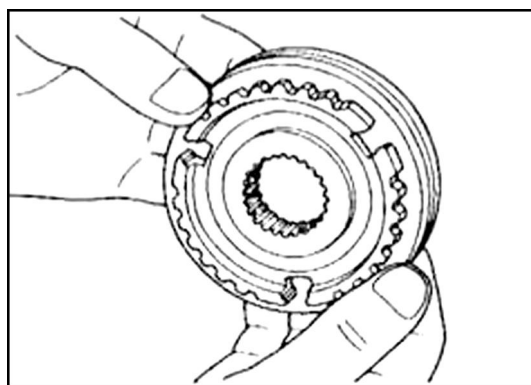

**6MT Transmission****(V) Assembly****1. Assemble input shaft assy.**

- 1). Smear lubrication on input shaft bearing end before mounting the bearing.

Mount the ball bearing (in the front of input shaft) on the input shaft.

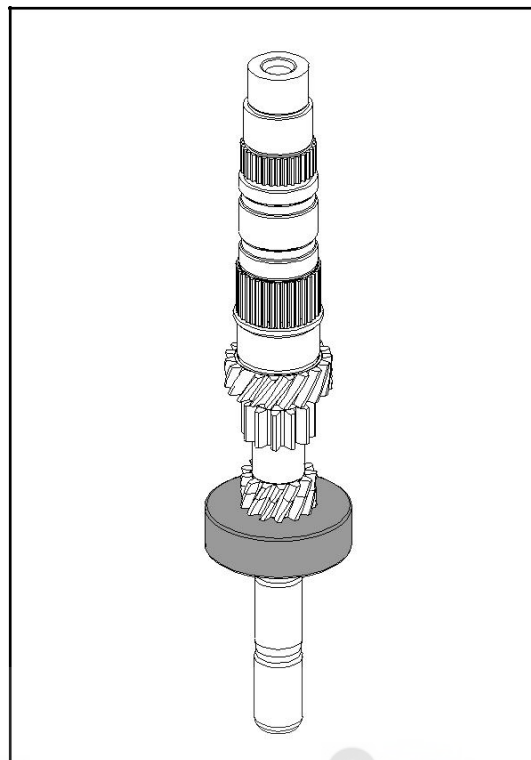

- 2). Mount the 3<sup>rd</sup> needle bearing and input 3<sup>rd</sup> gear fitting on the input shaft.

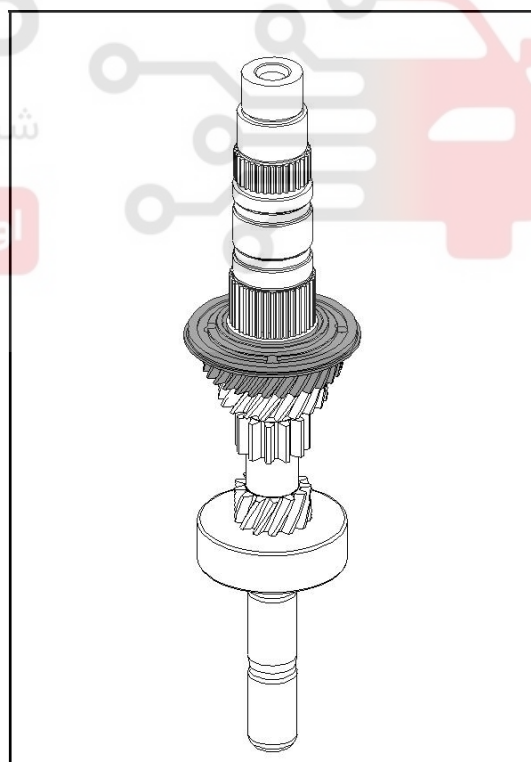

## 6MT Transmission

3). Mount 3/4 synchronizer assy and 3/4 synchronizing ring on the input shaft.

△Notice:

1. Please pay attention to the direction of synchronizer during assembly.
2. The gear hub trisection groove should match the outer ring trisection boss.

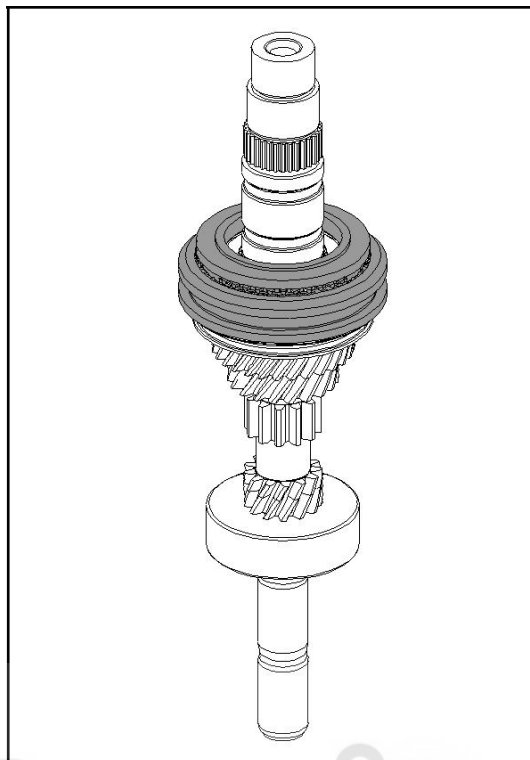

4). Smear lubrication on input shaft 4<sup>th</sup> gear, and then mount the input 4<sup>th</sup> gear sleeve on input shaft.

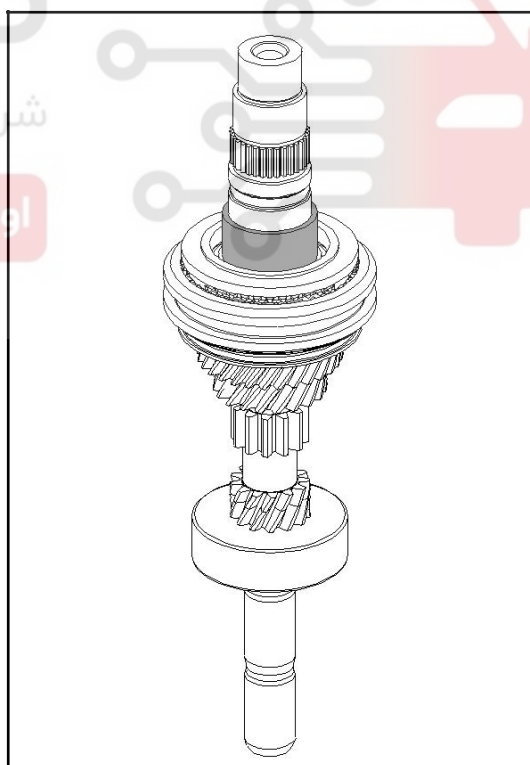

دیجیتال خودرو  
شرکت دیجیتال خودرو سامانه (مسئولیت محدود)

اولین سامانه دیجیتال تعمیرکاران خودرو در ایران

**6MT Transmission**

5). Mount the 4<sup>th</sup> needle bearing and input 4<sup>th</sup> gear fitting on the input shaft.

△Notice: Smear lubrication when mount input 4<sup>th</sup> gear needle bearing, and smear again on the whole mounting place after assembly. The input 4<sup>th</sup> gear fitting should rotate flexibly and without nimbleness after the assembly.

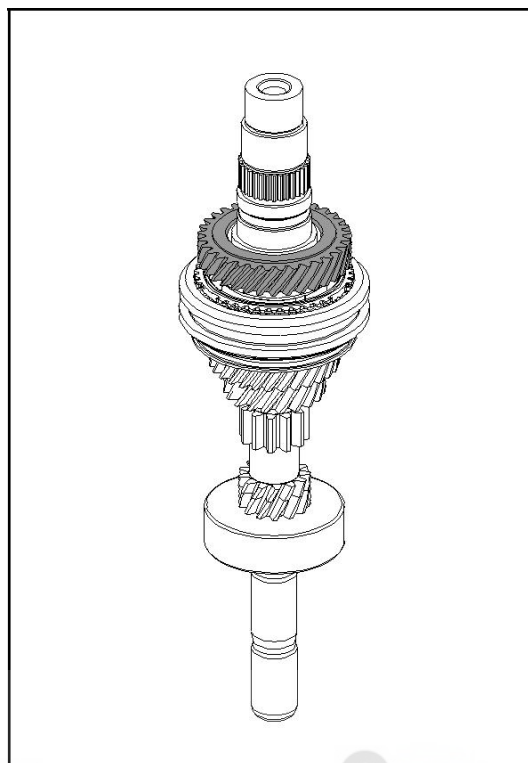

6). Smear lubrication on input shaft 5<sup>th</sup> gear, and then mount the input 5<sup>th</sup> gear sleeve on input shaft.

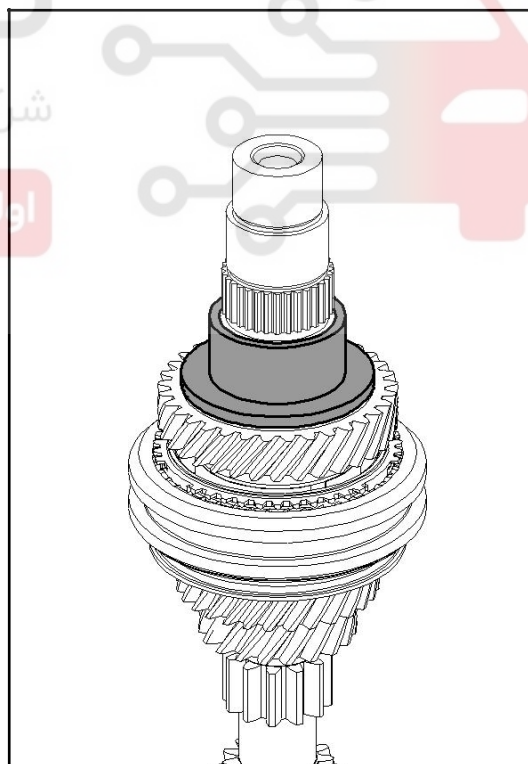

## 6MT Transmission

7). Mount the 5<sup>th</sup> needle bearing and input 5<sup>th</sup> gear fitting on the input shaft.

△Notice: Smear lubrication when mount input 5<sup>th</sup> gear needle bearing, and smear again on the whole mounting place after assembly. The input 5<sup>th</sup> gear fitting should rotate flexibly and without nimbleness after the assembly.

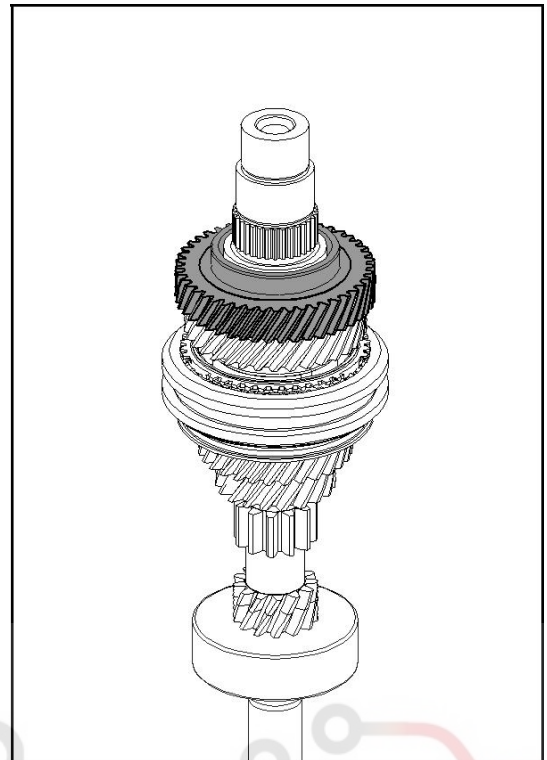

8). Mount 5/6 synchronizer assy and 5/6 synchronizing ring on the input shaft.

△Notice:

1. Please pay attention to the direction of synchronizer during assembly, the conical surface of synchronizing ring shall be downward.

2. The gear hub trisection groove should match the outer ring trisection boss.

9). Smear lubrication on input shaft 6<sup>th</sup> gear, and then mount the input 6<sup>th</sup> gear sleeve on input shaft.

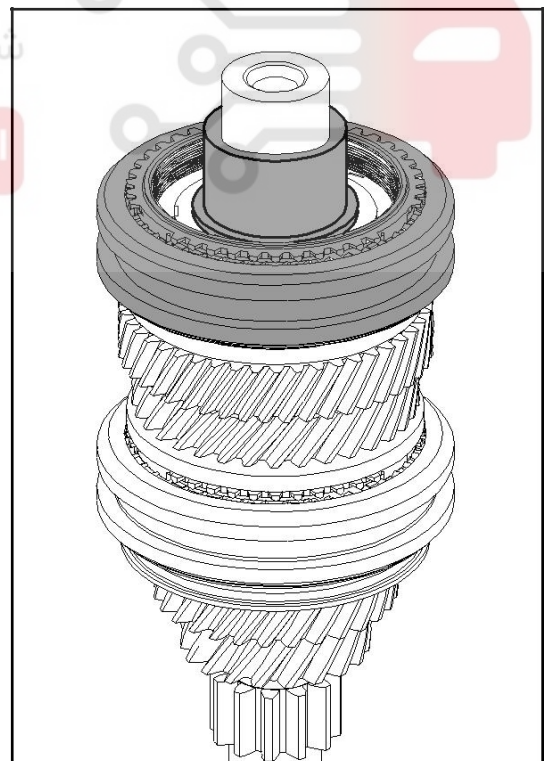

## 6MT Transmission

10). Smear lubrication on input shaft 6<sup>th</sup> gear needle bearing, and then mount the input 6<sup>th</sup> gear needle bearing, fitting and thrust washer on input shaft.

△Notice: Smear lubrication on the whole mounting place after assembly. The input 6<sup>th</sup> gear fitting should rotate flexibly and without nimbleness after the assembly.

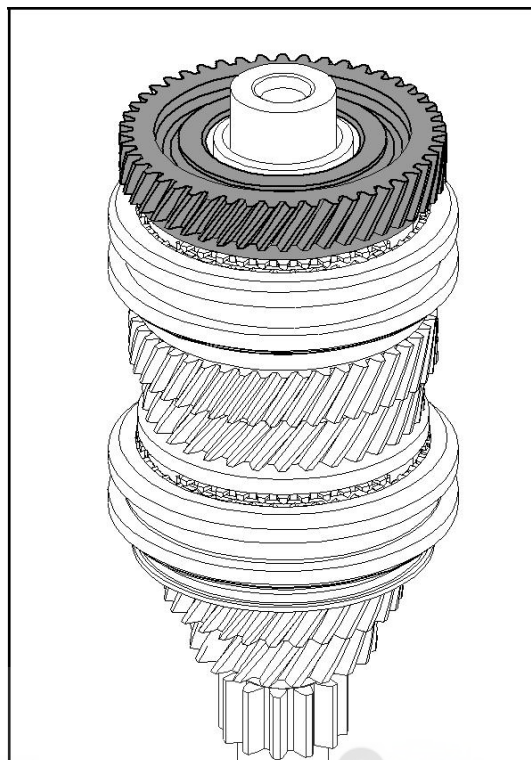

11). Smear lubrication on input shaft bearing end , and then mount the ball bearing (behind the input shaft) on the input shaft.

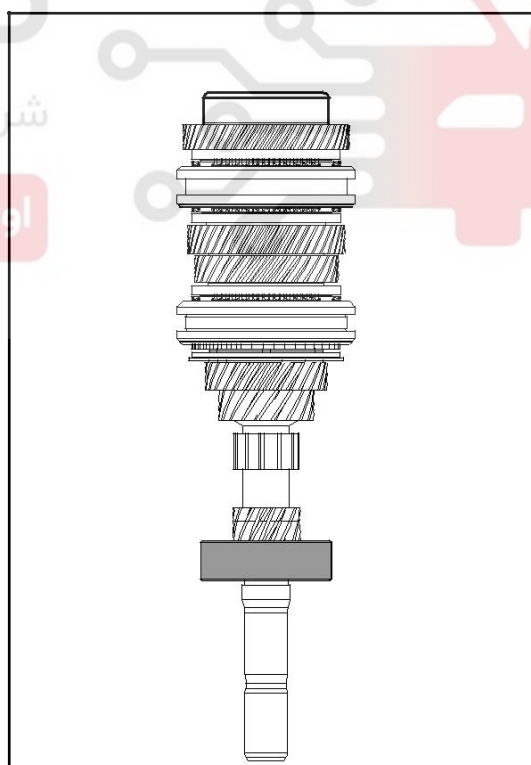



## 6MT Transmission

12). Mount the plug screw on the input shaft.

13). After press-mounting the bearing, assemble the snap ring on input shaft front bearing to finish the assembly of input shaft assy.

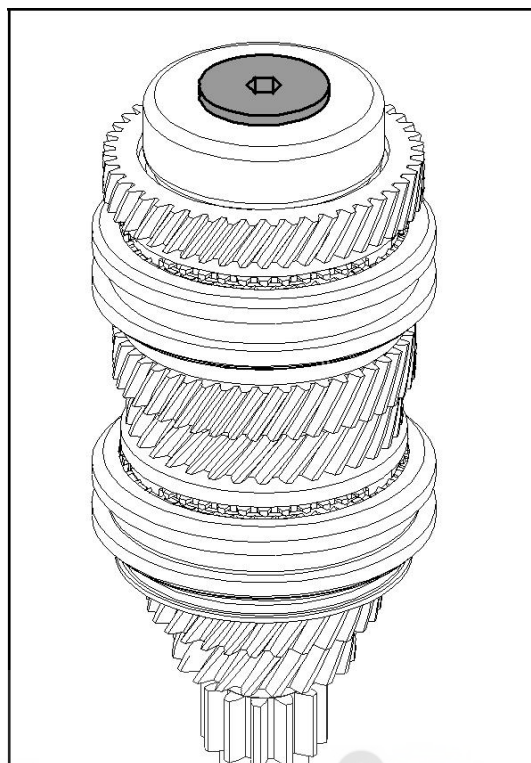

## 2. Assemble output shaft assy

1). Smear lubrication on output shaft bearing end before mounting the bearing; press-mount the tapered roller bearing (in the front of output shaft).

△Notice: Please pay attention to the direction of bearing during press-mount the tapered roller bearing.

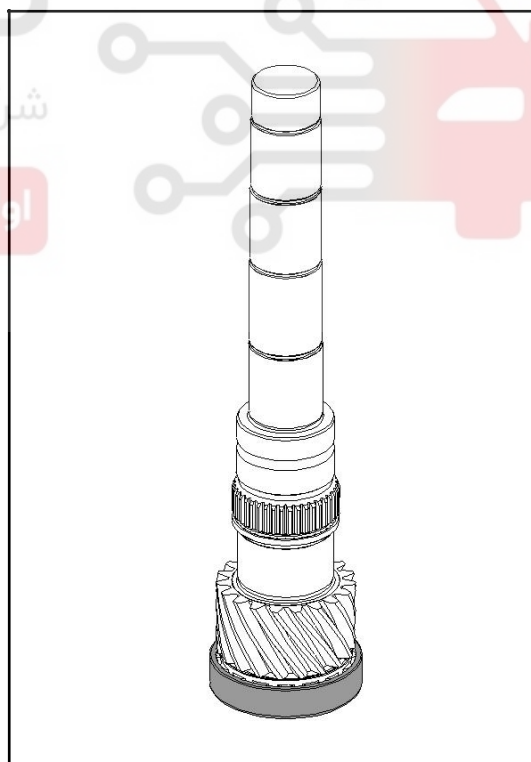

## 6MT Transmission

2). Smear lubrication on output 1<sup>st</sup> gear needle bearing; mount the output 1<sup>st</sup> needle bearing and output 1<sup>st</sup> gear fitting.

△Notice: Smear lubrication on the whole mounting place after assembly.  
The output 1<sup>st</sup> gear fitting should rotate flexibly and without nimbleness after the assembly.

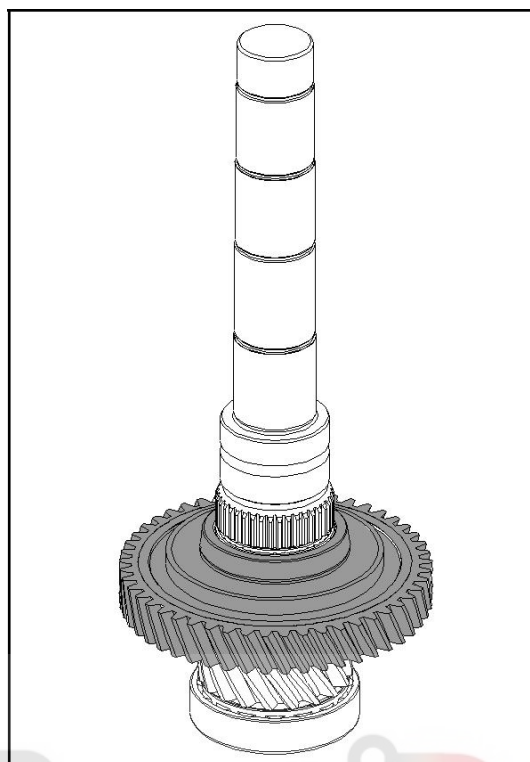

3). Mount 1/2 synchronizer assy and 1/2 synchronizing ring on the output shaft.

△Notice:

1. Please pay attention to the direction of synchronizer during assembly.
2. The gear hub trisection groove should match the outer ring trisection boss.

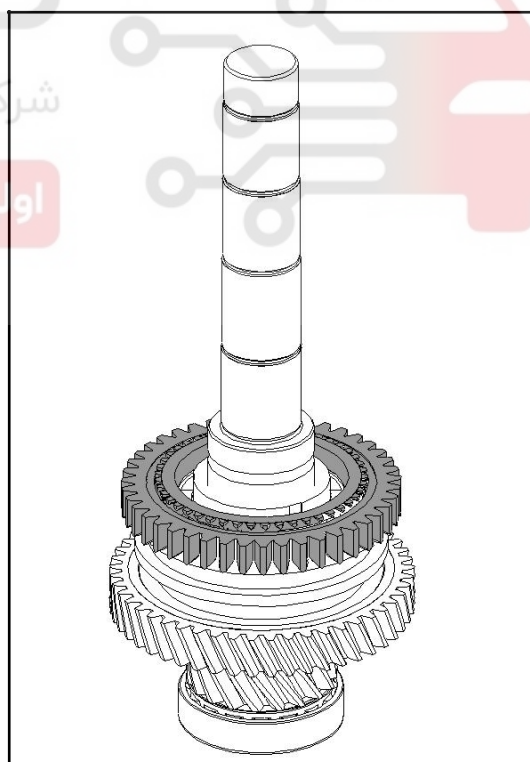

## 6MT Transmission

6). Heat the output 4<sup>th</sup> gear to  $130^{\circ}\pm 5^{\circ}$ , then press-mount it on the right position.

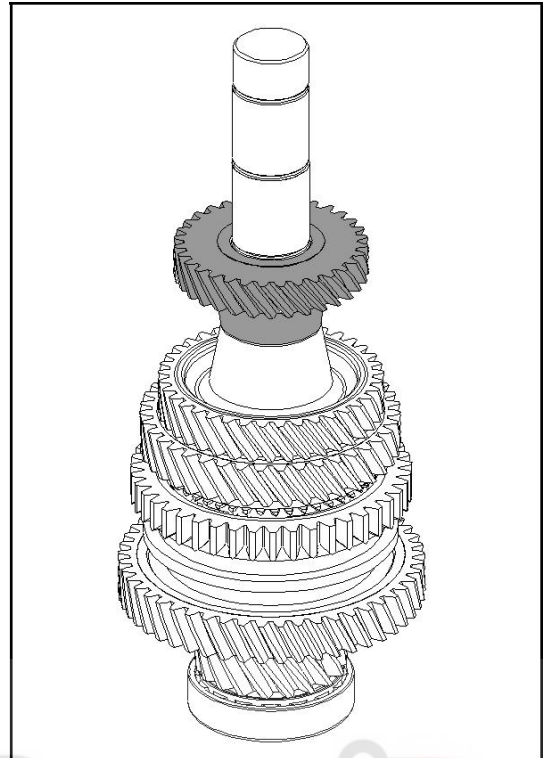

7). Heat the output 5<sup>th</sup> gear to  $130^{\circ}\pm 5^{\circ}$ , then press-mount it on the right position.

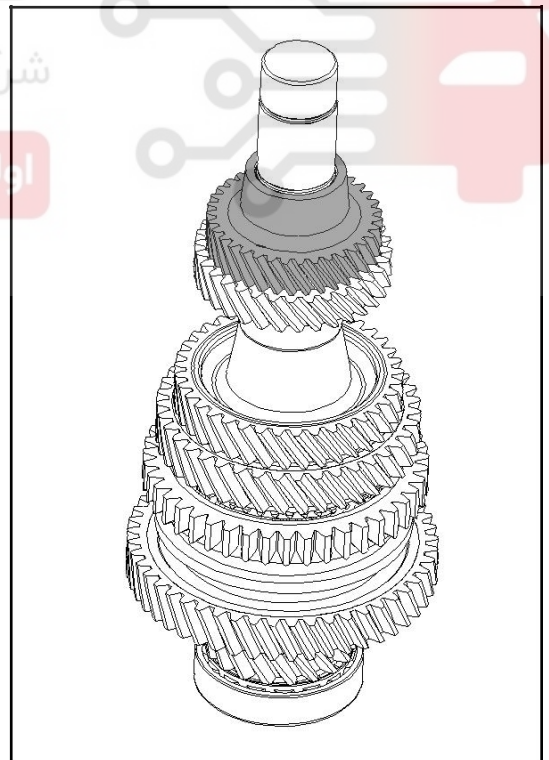

**6MT Transmission**

8). Heat the output 6<sup>th</sup> gear to  $130^{\circ}\pm 5^{\circ}$ , then press-mount it on the right position.

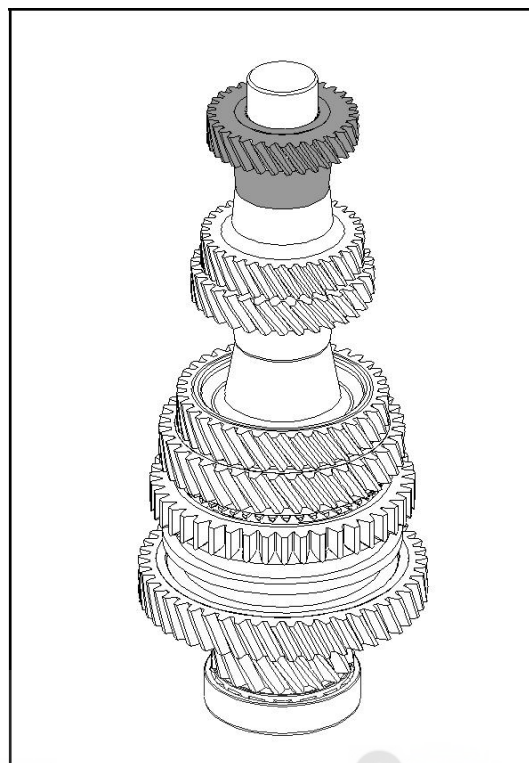

9). Smear lubrication on input shaft bearing end first; press-mount the output shaft rear tapered roller bearing and adjusting shim (rear bearing of output shaft).

△Notice:

1. Please pay attention to the direction of bearing during press-mount the tapered roller bearing.

2. Selecting the shim during mould assembling.

10). Finish the assembly of output shaft.

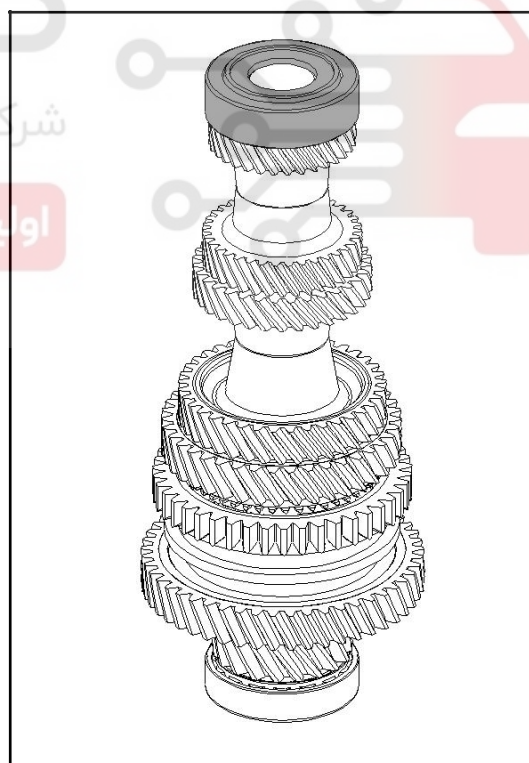

## 6MT Transmission

## (VI) Mounting

1. Mount input and output shaft assembly
  - 1). Put the input shaft and output shaft assembly into the shell.
  - 2). Mount the pressure plate and tighten the 4 screws.  
Tightening torque: 8~12N·m
2. Mount select and shift gear fork and shifting fork shaft
3. Mount reverse gear intermediate shaft assembly
4. Mount rear housing
5. Mount the release bearing and release shifting fork fitting
6. Mount select and shift gear base assembly
7. Mount reverse switch assembly
8. Mount transmission assembly

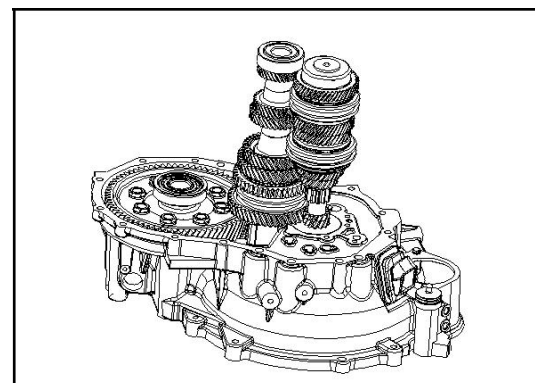

## XIII Differential case assembly

## ( I ) Special tools

No.	Tool number	Tool name	Diagram	Function
1	27G0059	Mounting tool of differential case oil seal		Mount differential case oil seal
2	27G0063	Mount and dismount heel block of differential case bearing		Mount and dismount differential case bearing
3	27G0064	Mounting tool of differential case bearing		mount differential case bearing

## ( II ) Dismounting

1. Dismount transmission assembly (Refer to Chapter Transmission assembly)
2. Dismount reverse switch assembly (Refer to Chapter Reverse switch assembly)
3. Dismount select and shift gear base assembly (Refer to Chapter Select and shift gear base assembly)
4. Dismount the release bearing and shifting fork assembly (Refer to Chapter Release bearing and shifting fork assembly)
5. Dismount rear housing (Refer to Chapter Rear housing)
6. Dismount reverse gear intermediate shaft assembly (Refer to Chapter Reverse gear intermediate shaft assembly)
7. Dismount select and shift gear fork and shifting fork shaft (Refer to Chapter Select and shift gear fork and shifting fork shaft)
8. Dismount input and output shaft (Refer to Chapter Input and output shaft)
9. Dismount differential case
  - 1). Take out the differential case assy. from the transmission rear housing.

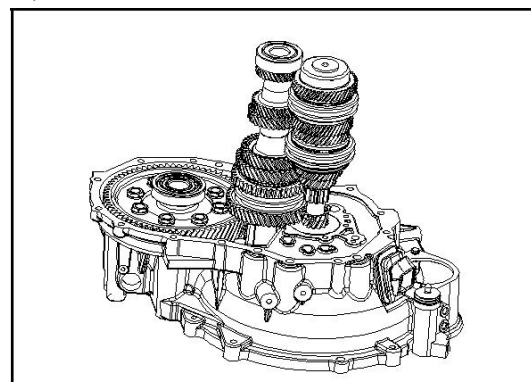

## 6MT Transmission

## (III) Disassembly

1. Disassembling differential case assy.

1). Use bearing puller to remove off the driven gear side bearing of final drive.

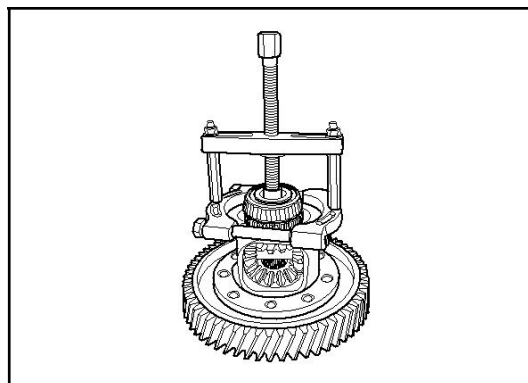

2). Dismount the driven gear fixed bolts of final drive.

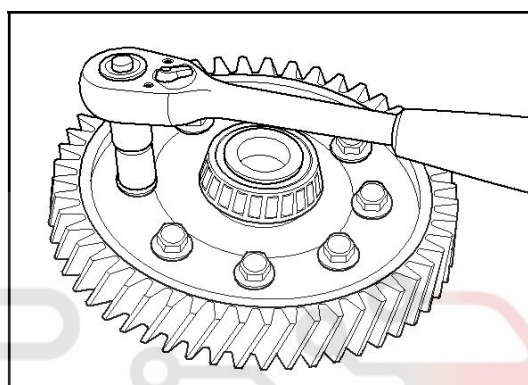

3). Take down the driven gear of final drive.

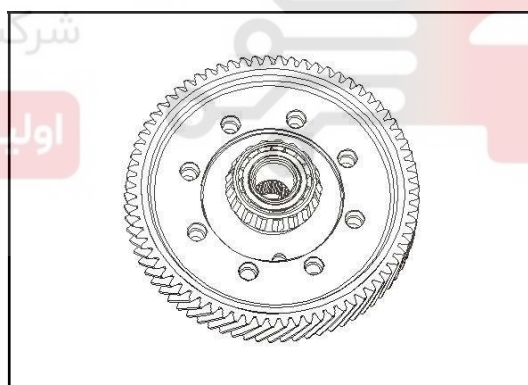

4). Use bearing puller to dismount side bearing at the opposite of final drive gear.

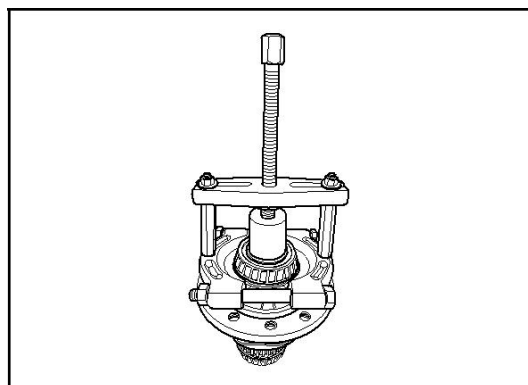

6MT Transmission

5). Use proper tool to dismount the planet axle lock-pin.

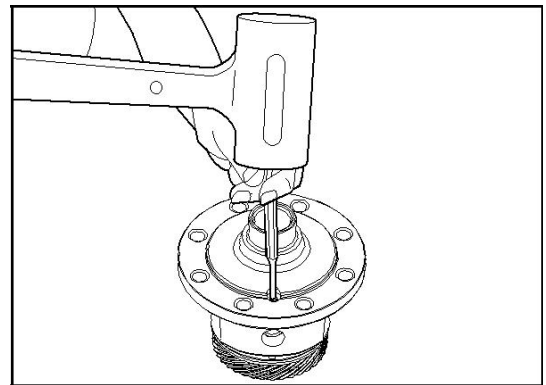

6). Take out the planet axle.

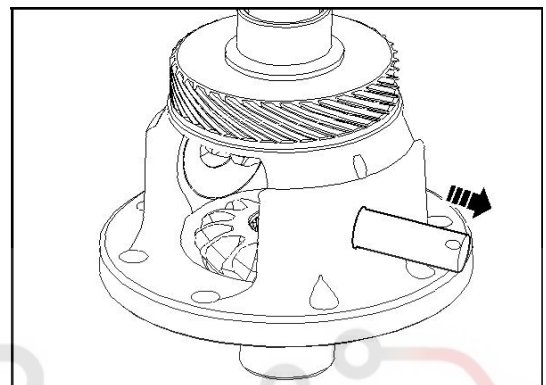

7). Rotate the planet gear.

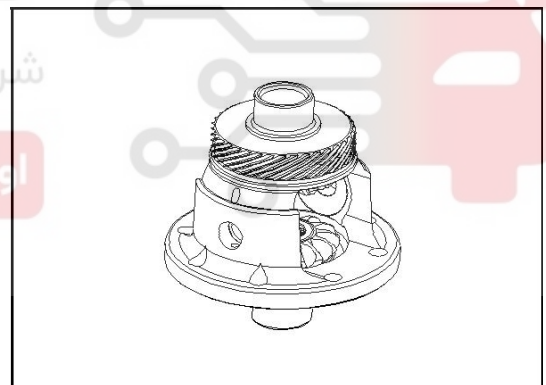

△ Notice: Rotate the planet gear by 90 degree as showed in the picture.

8). Take out the planet gear.

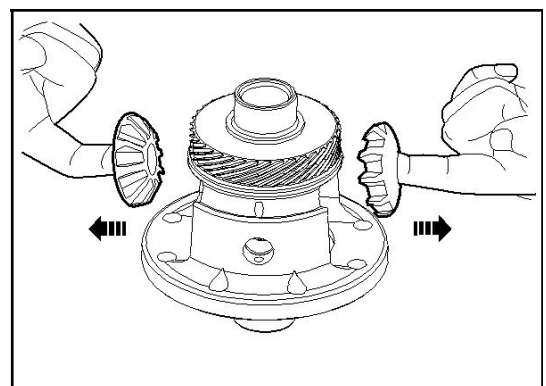

دیجیتال خودرو  
 شرکت دیجیتال خودرو سامان (مسئولیت محدود)  
 اولین سامانه دیجیتال تعمیرکاران خودرو در ایران

## 6MT Transmission

9). Take out the side output pinion at the opposite side of final drive gear.

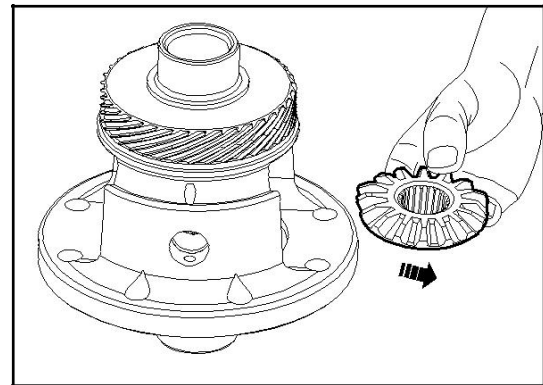

10). Take out the side output pinion at one side of final drive gear.

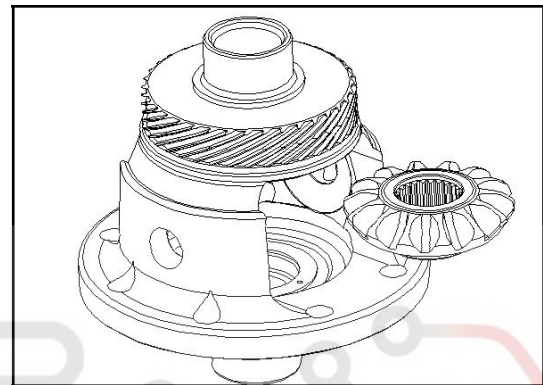

11). Take out the planet gear gasket of differential case.

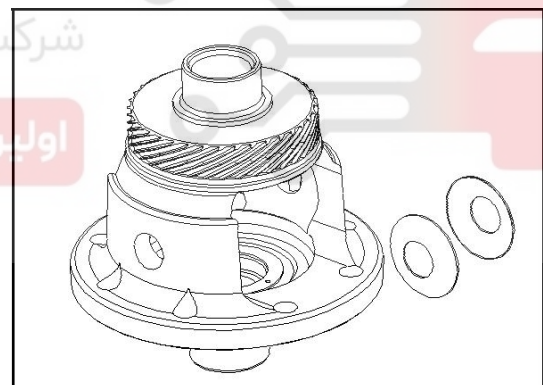

12). Take out the planet gear gasket of differential case.

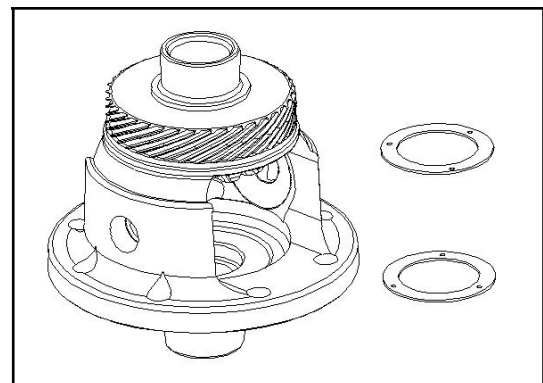



6MT Transmission

13). Dismounted planet gear and output gear.

△Notice: if the engage clearance between planet gear and output gear has to be adjusted, you can adjust the thickness of adjusting shim.

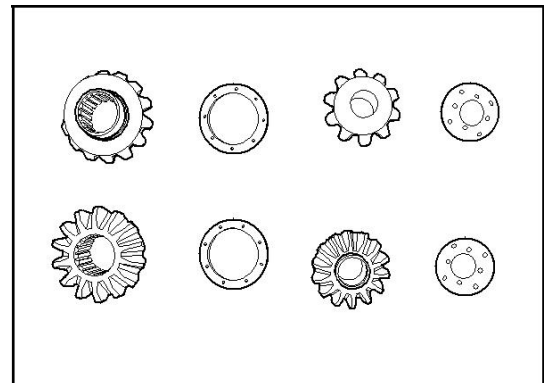

(IV) Mounting

1. Mount the differential case assy.

1). Use proper tool to assemble bearing at the gear side of final drive.

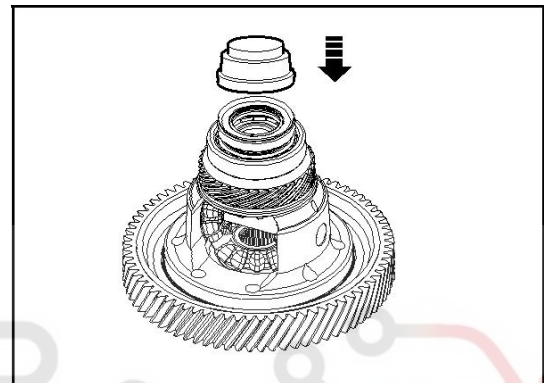

2). Use proper tool to assemble bearing at the opposite side of final drive gear.

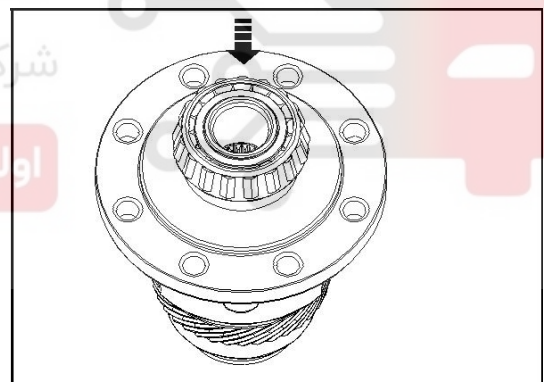

3). Mount planet gear and output gear.

△Notice: Pay attention to the state of shim between planet gear and output gear during assembly.

4). Mount planet axle.

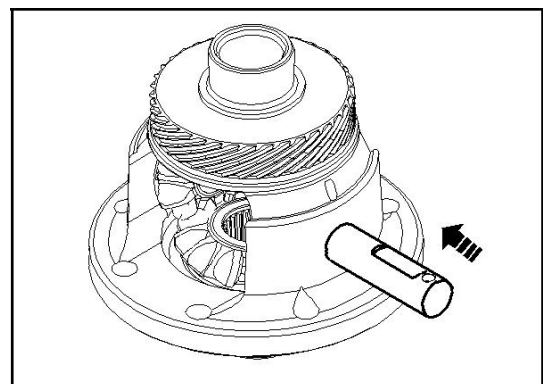

## 6MT Transmission

5). Use proper tool to mount the planet axle lock-pin on the right position.

△Notice: Put the surface of planet axle lock-pin with spline groove upward.

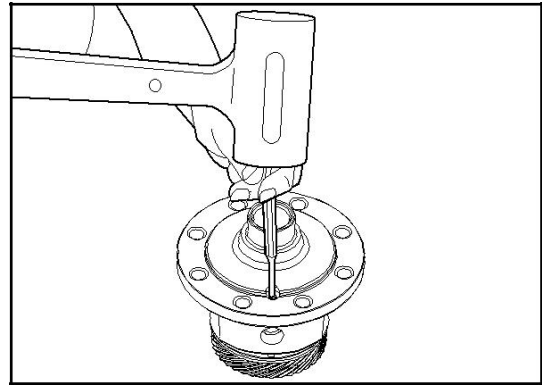

6). Mount the driven gear of final drive.

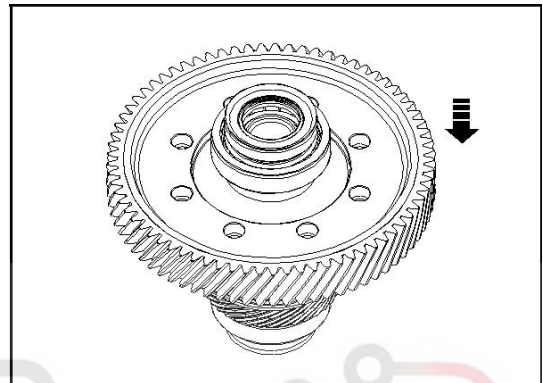

7). Tighten the fixed bolts of final drive driven gear diagonally.

Tightening torque 75~85N·m

△Notice: Fixing bolts in diagonal sequence.

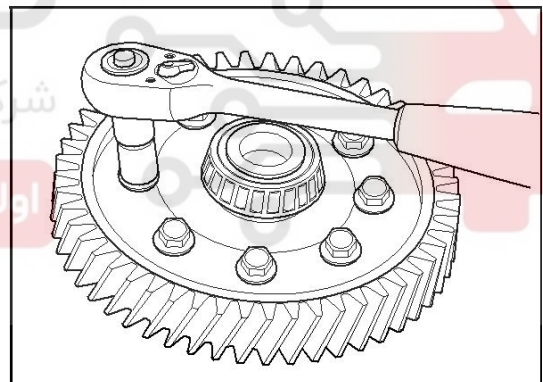

## (V) Mounting

1. Mount the differential case assy.
  - 1). Mount the differential case assy on the transmission rear housing.
2. Mount input and output shaft assembly.
3. Mount reverse gear intermediate shaft assembly.
4. Mount rear housing.
5. Mount the release bearing and release shifting fork fitting.
6. Mount select and shift gear base assembly.
7. Mount reverse switch assembly.
8. Mount transmission assembly.

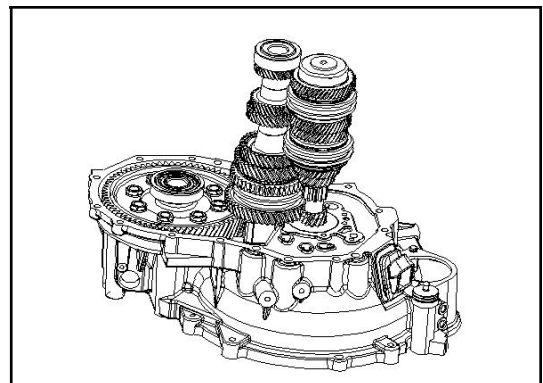

# Transmission (CVT)

## I Summary

### ( I ) Structure summary

The continuously varying transmission drive ratio can be achieved by means of a device, the device includes two opposed cone wheel and V-shaped driving strip wrapped around the two wheels. The transmission ratio of the device is transmitted to the differential in the transmission through the intermediate shaft.

This manual briefly describes the transmission, including the design and function of the various components of the transmission, and elaborates the power-train and control devices. In addition, the manual also elaborates the transmission oil cooling system and external shift mechanism.

The continuously variable shift model can make you have more comfortable driving, and can improve vehicle performance.

Use this type of automatic transmission has the following advantages:

- In a constant vehicle speed situation, the engine has lower speed;
- Improve emission / reduce fuel consumption;
- Better NVH (noise, vibration, harshness);
- Steady acceleration;
- Have a maneuverability on the mountain road.

### Comparison of Traditional automatic transmission and a continuously variable transmission

The figure below shows the CVT and manual or regular automatic transmission ratio change chart. regular automatic transmission (transmission device) gear ratio is a series of fixed values.

When the transmission is shifted to higher gear, the gear ratio will vary according to throttle opening size along the thick solid or broken lines shown on the right. However through the use of continuously variable transmission, can obtain the gear ratio change chart as shown in the left, two transmission shift points all related with the throttle opening degree applied by the driver.

When the throttle opening degree becomes larger, the engine speed increases, the transmission shifted into high gear; if use traditional transmission, the engine speed will be significantly decreased, while use continuously variable transmission will not. CVT can be into high gear at the engine speed remains unchanged situation by moving rotating cone (as description below). In addition, you can also choose other shift strategy, which will help new users faster accept CVT.

CVT (left) and 4-speed AT (right) ratio change chart

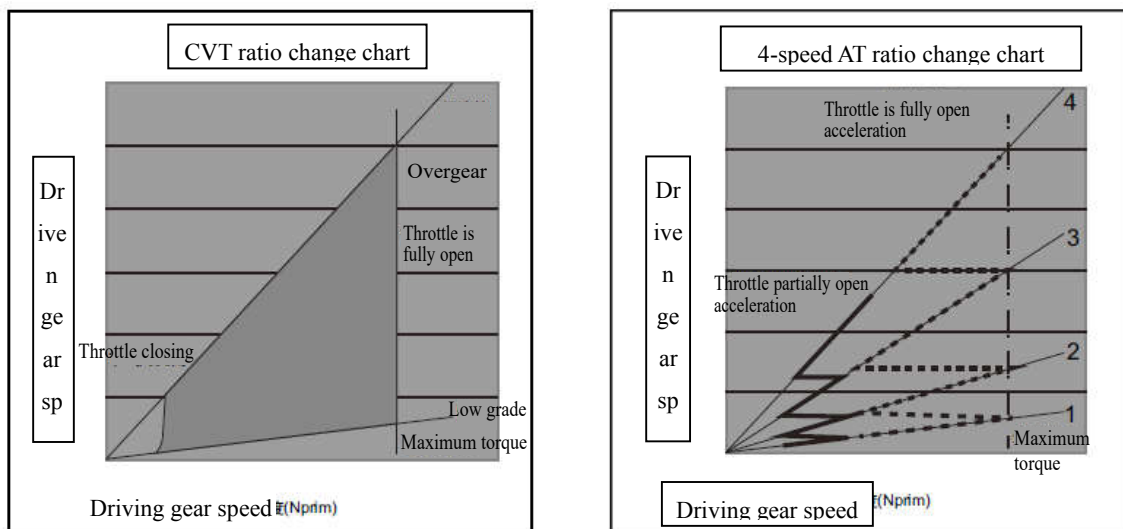

CVT Transmission

Sectional view of the transmission

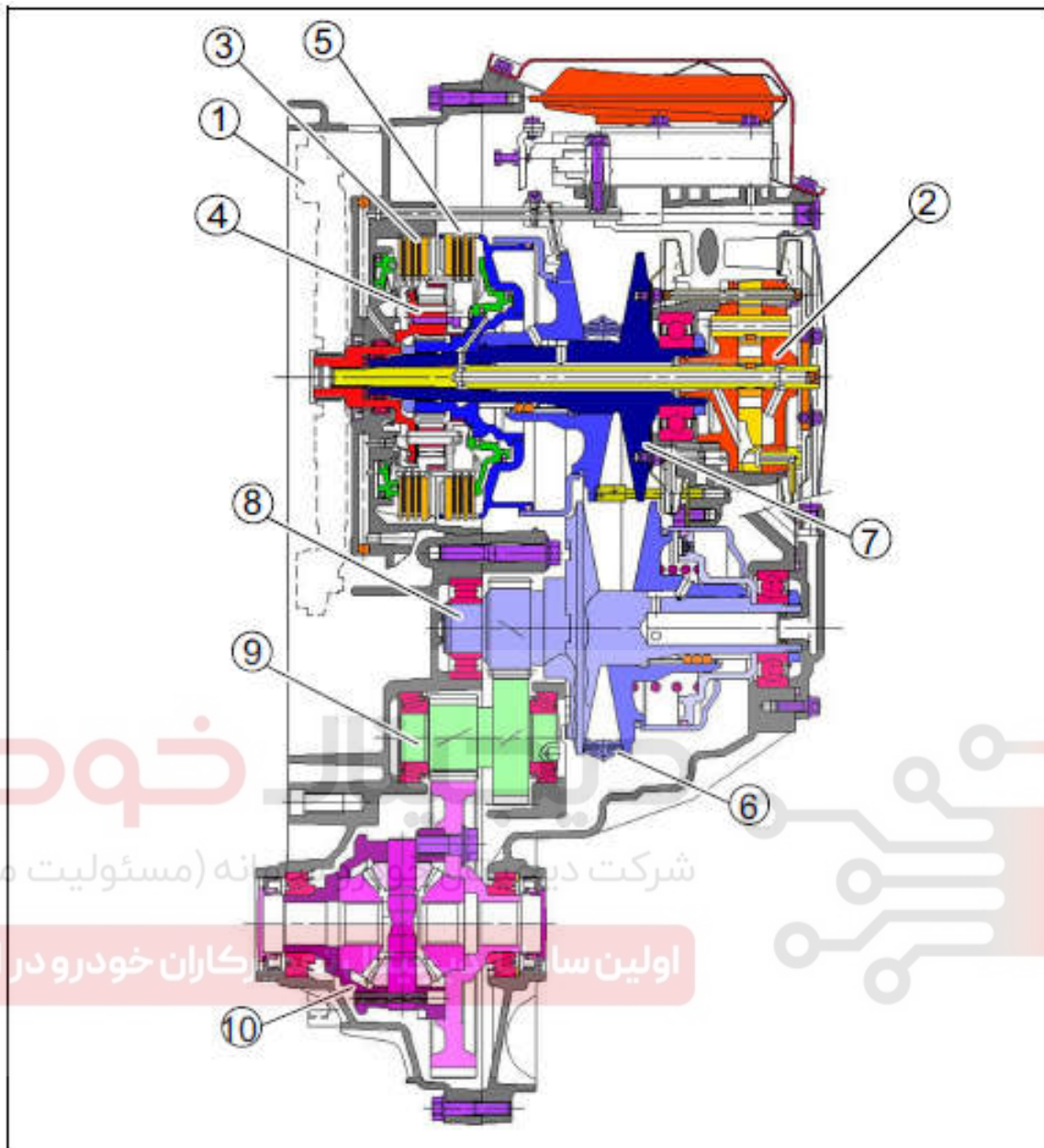

- 1. Torsion damper / flywheel
- 2. Pump
- 3. Reverse clutch
- 4. Planetary body
- 5. Forward clutch

- 6. Steel strip
- 7. Driving bevel wheel
- 8. Driven bevel wheel
- 9. Intermediate shaft
- 10. Differential

خودرو  
 شرکت دیپ (مسئولیت محدود)  
 اولین سازندگان خودرو در ایران

CVT Transmission

Transmission exploded view

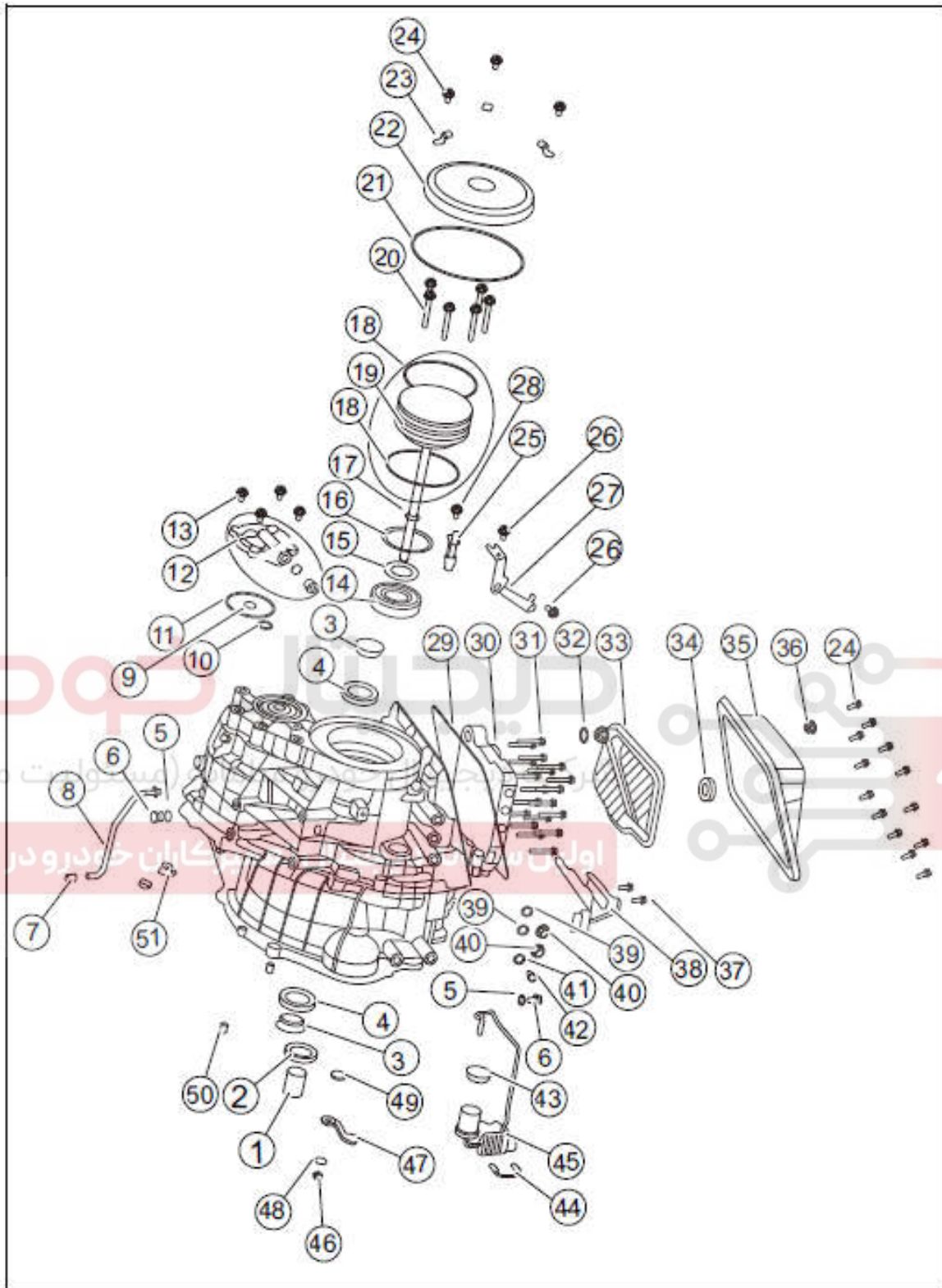

1. Input shaft rubber protective sleeve 482235
2. Input shaft oil seal 481274
3. Differential oil seal cover 481296
4. Differential oil seal 483329
5. screw plug gasket 481247
6. oil filler bolt 481248
7. ventilator tube cap 483420
8. ventilator tube assy 483114

**CVT Transmission**

9. Driven bevel wheel cover O type gasket (small)
10. Driven bevel wheel cover gasket 481877
11. Driven bevel wheel cover O type gasket (big) 481255
12. Driven bevel wheel cover 482982
13. screws driven bevel wheel cover countersunk 482208
14. Driving bevel wheel ball bearing 482294
15. Driving bevel wheel shaft nut 481293
16. Cone type spring washer 481856
17. Pump seals 481826
18. Pump O-ring 481259
19. oil pump (including o-ring) 483323
20. pump bolt 481284
21. Driving bevel wheel shaft cover O-ring 481253
22. Driving bevel wheel shaft cover 481173
23. Driving bevel wheel shaft cover snaps 481189
24. Driving bevel wheel shaft cover bolt 481283
24. sump bolt 481283
25. speed sensor 482410
26. speed sensor bracket mounting bolts at differential 481289
27. speed sensor bracket at differential 482468
28. Speed sensor mounting bolts 481283
29. Oil pan gasket 482504
30. valve assy 482589
31. valve bolt 481311
32. plastic clip 482253
33. Oil filter assy 483165
34. Sump magnet 481870
35. oil sump assy
36. oil drain screw 482442
37. Driving mode sensor mounting screw 481090
38. Driving mode sensor 482493
39. Oil cooler plug O type gasket 481258
40. Oil cooler plug 482121
41. Oil level plug gasket 481249
42. oil level plug 481250
43. Main connector cover 482104
44. main connector snap 482105
45. main connector and inner harness 482475
46. Gear selection lever nut 481329
47. Gear selection lever 483185
48. Gear selection lever nut gasket 482584
49. Seal (gear selection shaft) 482099
50. Locating Pin 483138
51. material snap 481456



## ( II ) System Principles

CVT Transmission components can be divided into three groups according to the corresponding function.

- Group 1 - mechanical transmission device function of this component is to provide mechanical transmission and torque transfer.
- Group 2 - the control system associated with the control system components. According to the load conditions and drive requirements, the control system ensures that the transmission power is transmitted and to change the transmission ratio at the appropriate time.
- Group 3 - some components of the external connection apparatus connected to the outside of the transmission. Among these components, some located within the transmission or gearbox connected, and some components are part of the whole system, but they are distributed in other parts of the vehicle.

## Group 1 mechanic torque transmission

## Planetary body

Planetary body can provide the transmission have forward and backward driving torque. Engine torque usually passed to the transmission through the planetary carrier input shaft. Engaging the forward direction of the multiple disc clutch can be directly connected to the planet carrier sun gear, at this time by the engagement, the planet carrier and sun wheel become a whole rotation, the engine torque is transferred directly to the driving wheel. Planetary gears do not transmit any torque, so there is no mechanical loss, and the rotation direction of the drive wheel will be consistent with the rotation direction of the engine. This is the forward mode.

Reverse mode, engaging the reverse multiple disc clutch mechanism allows the planetary ring gear is held stationary, the planet carrier drives three pairs of planetary gear sets so the sun gear can counter-rotate, the gear ratio at this time is 1: 1.1, there will be a slight deceleration to compensate planetary mechanism frictional losses.

## Planetary body

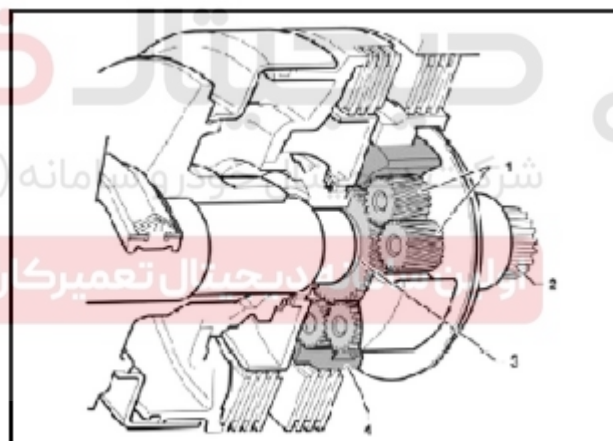

1. planet gear                      3. sun gear  
2. input shaft                      4. ring gear

## Multiple disc clutch

Have two sets of multi-plate wet clutch: one for forward and one for reverse. Each set has three friction disc, six total friction surface. hydraulic system control the clutch can make the vehicle go forward smoothly at any throttle opening level, when the driving gear is engaged, through the control amount of the clutch engagement can also stop the vehicle. Cooling oil directly cools the clutch disc to prevent overheating of the friction surface.

## The clutch at the planetary mechanism

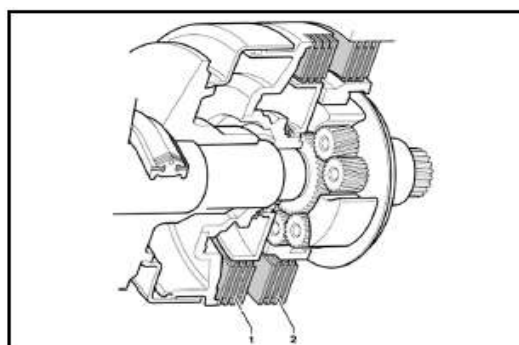

1. forward clutch set  
2. reverse clutch set

## CVT Transmission

## Bevel wheel and steel strip

The main design features of the CVT is a pair of "V" type bevel wheel connected by a steel belts. driving wheel and driven wheel center distance is 155mm. Each bevel wheel is divided into two halves: half fixed, half axial sliding, tilt are both 11 °. Width of 24mm "Van Doorne" push belt is used for transmitting torque between wheels (if you want to use a larger torque values, you can use 30mm belt). By the way of injecting lubricate oil to cools the drive belt . In order to reduce the belt angle error when shift gear, the two movable gear halves are placed between the two diagonal positions, and then move the gear halves connected to each hydraulic cylinder / piston. Hydraulic pressure is controlled by the control system. details refer to "group 2 control system ". Spherical spline can prevent the movable gear halve from rotating with the fixed gear halve.

Because the sun gear is connected to driving bevel wheel by the spline, so the torque can be directly transmitted to driving bevel wheel from the planetary gear set. Steel strip transmits power to the driven wheels from the driving bevel wheel, then the power is transferred to the intermediate gear shaft.

Driven wheel torque and speed is determined by the position of the driving strip. Design the two gear dimensions, so they can provide a 2.416: 1 - 0.443: 1 gear ratio, the maximum ratio is 5.45 times the minimum transmission ratio. Overdrive ratio is the minimum fuel consumption.

Driving strip is made by 450 steel disc and 24 strips, each side has 12 strips.

## Strip

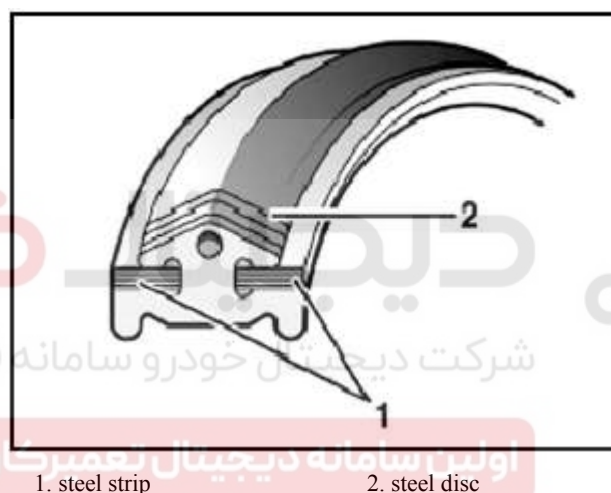

## Intermediate shaft

Intermediate shaft (pinion shaft) can make the driven bevel and differential meshed helical gear set reduce speed, so you can ensure the correct direction of the drive shaft rotation. The speed decelerate between driven bevel gear and intermediate shaft largely improves vehicle performance. Intermediate shaft is fixed by two bevel bearings which inside the clutch shell and inner the independent bearing seat.

## Differential

Like the manual transmission, the crown wheel torque transmitted to the wheels through a differential, crown wheel is fixed by 8 bolted to the differential housing, drive shaft is fixed by traditional rzeppa universal joints and seals to the differential inside. bevel bearing is used to fix differential.

## Mechanical manipulation

## Transmission ratio change

Traditional planetary gear automatic transmission ratio progression is limited, usually four, five or six, but the continuously variable transmission is different, as its name implies, the continuously variable transmission gear ratio varies continuously. Low gear (lower gear ratio) make it easier to start the vehicle stationary, the driving bevel wheel has a relatively small diameter but driven bevel wheel has a relatively large diameter. driving strip is used to transmit power and torque, if through increasing driving bevel gear diameter and narrow driven bevel gear diameter to select high ratio, this can produce acceleration. By controlling the degree of change to ensure the most appropriate gear ratio.

CVT has driving bevel wheel and driven bevel wheel, each bevel wheel consists of two half-bevel, one is fixed, the other can be moved by hydraulic control. Position of the belt on the wheel can determine transmission ratio. If move the movable half wheel close to fixed half, the driving strip will move to outer periphery. When the two halves of the bevel wheel separation, the wheel circumference will be smaller, driving bevel wheel and driven bevel wheel located at their respective semi-diagonal position, at this time driving bevel wheel with radius



CVT Transmission

shrinks, while the driven bevel wheel increase the belt radius.

Vehicle starting require low gear ratio, therefore, the driving bevel wheel separate to make the strip closed on the wheel , and the driven bevel wheel close to make strip moves on the outer peripheral. high speed need big transmission ratio, so the driving bevel wheel movable half would move to fixed half, the bevel wheel circumference increase, at the same time, driven bevel wheel was separated , driven bevel wheel circumference decrease, then create high ratio. When the driving bevel wheel completely closed , driven bevel wheel completely separate, then produce the overdrive ratio. Driving bevel gear and driven bevel wheel transfers at about 1: 2.5 ratio.

Pulley position at low-speed

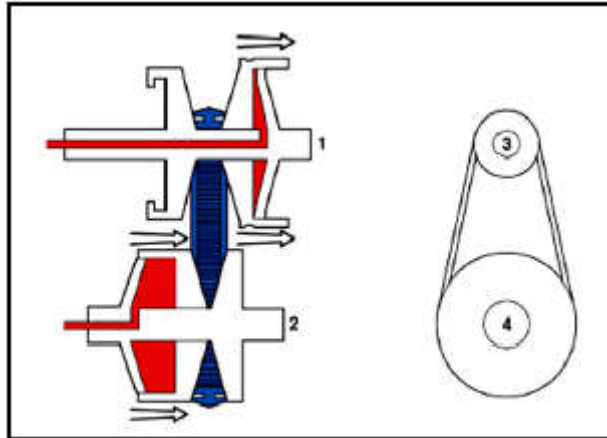

- 1. engine input
- 2. output to wheel
- 3. the minimum diameter of the transmission wheel (low speed)
- 4. The maximum diameter of the driven wheel (low speed)

Pulley position at high-speed

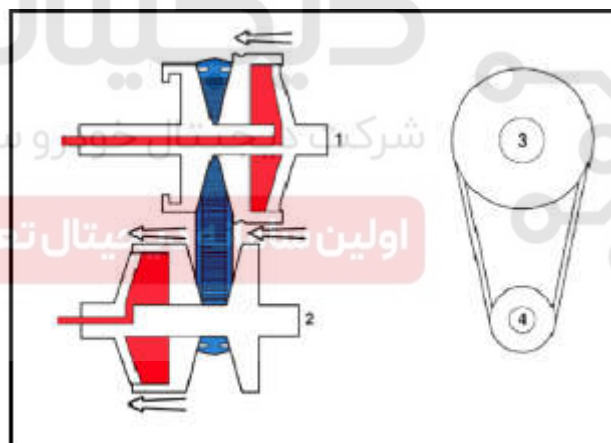

- 1. engine input
- 2. output to wheel
- 3. the minimum diameter of the transmission wheel
- 4. The maximum diameter of the driven wheel

· Selector lever is in neutral or the parking gear

In this state, the reverse clutch (2) and the forward clutch (4) separate, can not drive the wheel.

- Transmission input shaft (1) have the speed with the engine.
- Reverse clutch (2) separate.
- Forward clutch (4) separate.
- Planetary wheel ( 3 ) rotate around the sun gear idle
- The sun wheel does not move, driving wheel (5), driven wheel(7)and the vehicle also remain intact.

For all automatic transmission, only when gear in neutral or parking position can start the engine, when at the state of parking station, mechanical lock can prevent vehicle move. To avoid damaging the transmission, can use parking gear only when the vehicle is not moving.

CVT Transmission

Transmission torque mechanism shown at right

- 1. input shaft
- 2. reverse clutch
- 3. planetary gear
- 4. forward clutch
- 5. driving gear
- 6. Drive steel strip
- 7. driving gear

· Selector lever at forward gear

In this state, the forward clutch (4) engages the wheel make the vehicle move.

- Transmission input shaft (1) have the same rotation speed with the engine.
- Reverse clutch (2) separates.
- Forward clutch (4) engages.
- Planetary mechanism Planetary Gear (3), the sun gear and the ring gear rotate together.
- driving gear (5) have the same rotation speed with engine, forward direction.
- driven gear (7) is also forward direction, the speed is up to the transmission ratio at the moment.

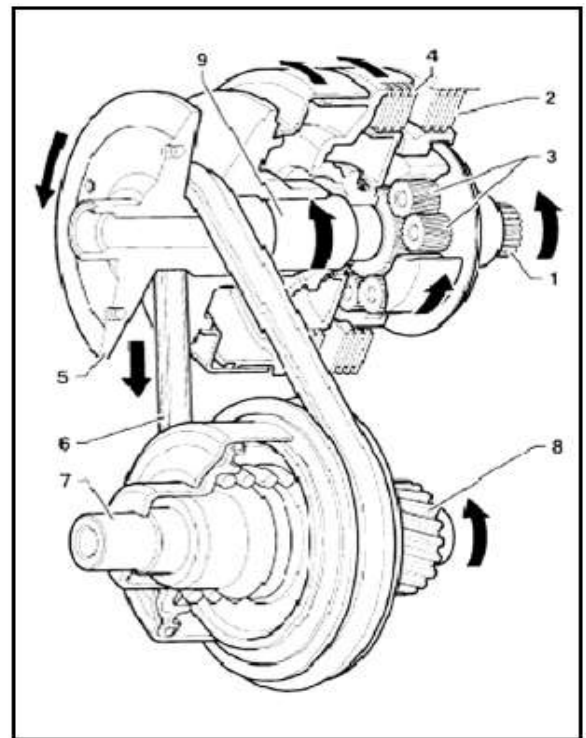

Transmission torque mechanism shown at right

- 1. input shaft
- 2. forward clutch
- 3. planetary gear
- 4. forward clutch
- 5. driving bevel gear
- 6. driving steel strip
- 7. driven bevel gear
- 8. driven bevel gear
- 9. input shaft

· Selection lever at reverse gear  
 In this state, the reverse clutch (2) engages, the ring gear (9) locked in the transmission housing. Planetary gear (3) makes the sun gear (10), the driving gear (5) and the driven gear (7) have the anti-direction of the transmission input shaft (1).

Now reverse gear is selected.

- Transmission input shaft (1) have the same rotation speed with the engine.
- reverse clutch (2) engages.
- forward clutch (4) separates.
- ring gear (9) connects the transmission case through reverse clutch (2).
- Transmission input shaft (1) direct drive the planetary gear (3) which rotates around the ring gear, thereby drive gear (10), pulley gear (5) and the driven bevel gear (7) rotated in reverse.

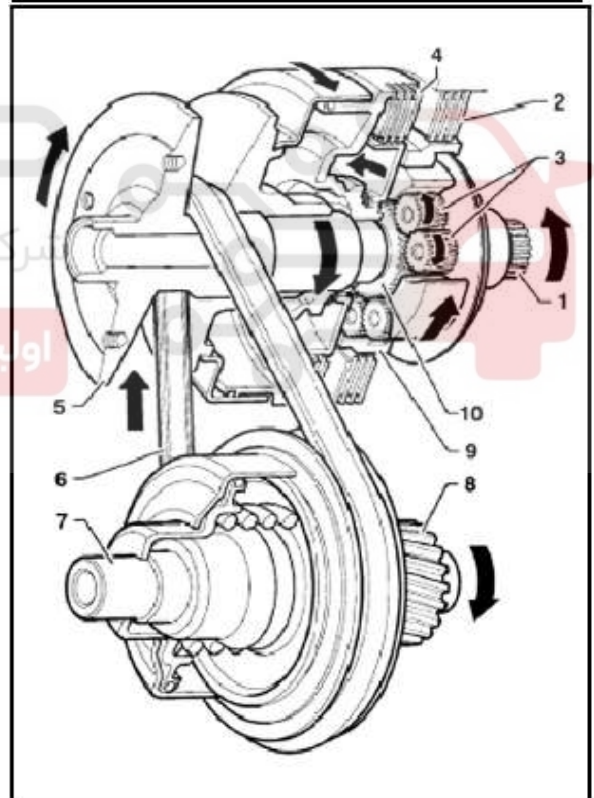

Transmission torque mechanism shown at right

- 1. input shaft
- 2. reverse clutch
- 3. planetary gear
- 4. forward clutch
- 5. driving bevel gear
- 6. driving steel strip
- 7. driven bevel gear
- 8. driven bevel gear
- 9. ring gear
- 10. sun gear

### Group 2 control system

Control system function as follows:

1. Make the steel strip tension of the clamping force adapted to the engine torque, to prevent strip slipping.
2. Control the forward and reverse clutch when driving.
3. Provide the best gear ratio for driving.
4. Provide the transmission with necessary lubricating and cooling oil.

### Oil pump

the oil pump inside the transmission is external gear pump, engine drives oil pump shaft , pump shaft connects the pump through hollow driving bevel gear axle. pump shaft is connected to planetary gear carrier through spline, the pump run as the engine rotation speed all the time, oil pump about 10 cm<sup>3</sup>/ r. system pressure is up to input torque , maximum 40~50bar.

Oil pump figure

oil pressure not only can used to control transmission hydraulic, but also can lubricate.

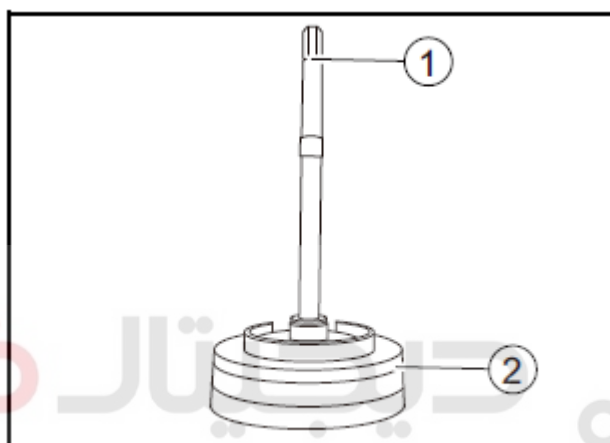

1. pump driving shaft 2. pump assy

Pump inlet

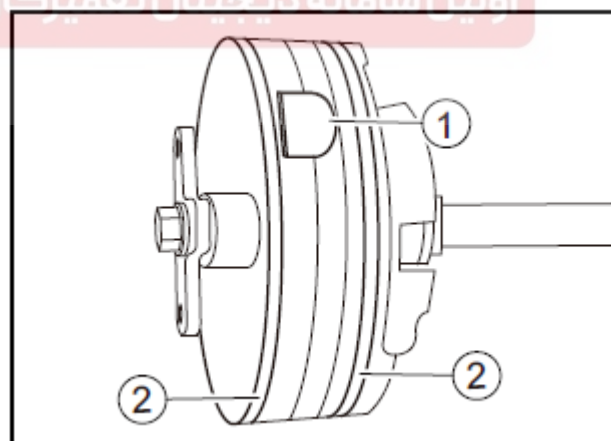

1. pump inlet

2. pump oil seal

### Transmission control device

Transmission control device makes the tension between the strip gear have the minimum value but no slipping, and also according to the driving strategy target value provides the gear ratio (based on the transmission input (active) and output (driven) speed calculate). During the life, the control device performance degradation can be kept within a certain range, and will not significantly affect the vehicle comfort and strip tension.

### Tension control device

Tension control device can obtain the minimum tension force required for the strip without slippage, so this would give the minimal impact to transmission efficiency, and this will get the lowest fuel consumption.

## CVT Transmission

Except normal driving situation, the tension control device also takes into account the maximum torque input and output at special situation, thus can extremely protect the transmission. control device also considers the anti-lock braking system (ABS) brakes, tire locking (no ABS) as well as other driving force control systems (such as ESP, anti-skid control devices, etc.). In addition, the device also considers the road and special circumstances, such as through road potholes, curbs, low friction coefficient changes, tire slip (such as at low friction coefficient road).

Software can compare the transmission's transmission performance and the transmission expected input torque. When the tension control device finds tension is insufficient, ECU receives torque reduced command, thereby adjust the engine torque to a suitable range. This function can also protect transmission.

If there is no electronic drive line systems in motor vehicles, ECU via CAN bus transfer torque signal, if there is no CAN bus, transmission control system (TCU) software itself generate default torque signal.

### Ratio control device

Transmission through the control of input and output pressure to balance the pressure of driving bevel gear and driven bevel gear , to control the transmission ratio. Through the driving bevel gear and driven bevel gear speed sensor signal can calculates the transmission ratio, and can change the output pressure to get the required ratio. The minimum pressure can be determined by the tension method. Transmission physical model will contribute to rapidly adjust the pressure level to variable operating point. Control software also takes into account the interference from other components of the transmission, so the software can minimize the delay error and target ratio errors, etc. (in order to improve fuel economy).

In order to ensure it meets the transmission mechanical and durability limit state requirements, we have developed a strategy to some drive limit situation. Except the speed limit, software also limit the transmission ratio change rate (set point) within the allowable range. In addition the software also avoided the engine speed due to vehicle speed and gear lever condition (POS) changes beyond a certain limit. To achieve this limitation, the software will reduce engine torque or change the drive car to high gear.

### Transmission control unit

Transmission control software integrated inside the TCU (Transmission Control Unit). TCU is installed in the cab.

### Group 3 external device

#### Oil cooler interfaces

In front of the transmission case has two oil cooler interfaces. An oil cooler interface mounted beside the engine radiator, make the lubricating oil temperature maintained below 120°C. Gearbox oil outflow from the right mouth, the mouth should be connected to the oil cooler of lower interface.

Oil flows into the transmission from the left side of the transmission, so the left mouth of the transmission should connects with the oil cooler upper interface.

#### Oil cooler interface

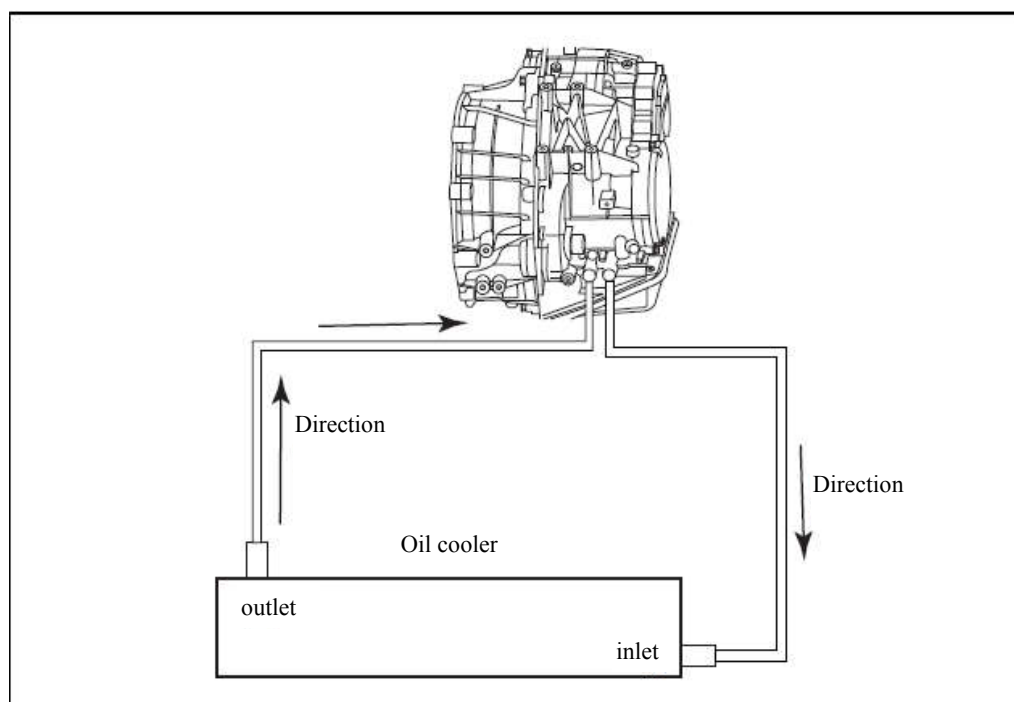

## CVT Transmission

### Gear selector

VT2 transmission includes parking gear (P), reverse gear (R), neutral (N), forward gear (D) and sport mode (S).

Customers can configure their own custom selector lever. For security reasons, we recommend to apply shift locking device as a starter protection.

CVT can also achieves manual mode, which requires the TCU add new pins to receive the signal, at the same time the maximum speed of the engine should be calibrated within a certain range, all of the JAC CVT has a manual mode.

### Main connector

Main connector is located on the transmission housing, including 16 pins. Harness connected by circular connectors.

Main connector on transmission

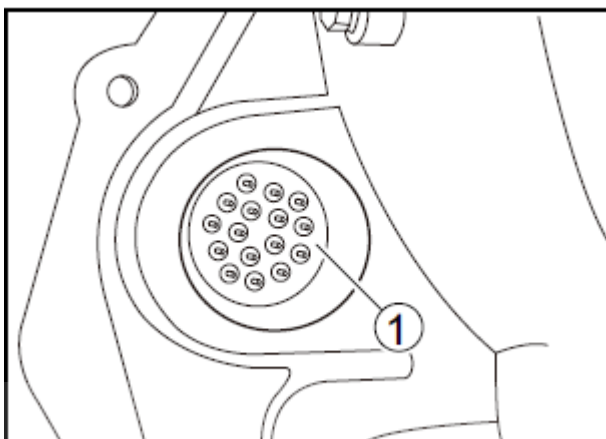

1. harness connector on the transmission

### Torsion damper

Most of the traditional automatic transmission use torque converter to connect the engine and the transmission input shaft, but this transmission uses torsion damper.

### (III) Technical parameters, maintenance parameters

No.	Project	Parameter
1	transmission	VT2
2	Lubrication oil	MOBIL(ESSO) EZL799(A)

### (IV) Torque parameters

No.	Project	Tighten torque
1	refuel plug	21±3
2	driven bevel gear shaft cover countersunk screws	9.5±0.95
3	driving bevel gear shaft bolt	197.5±17.5
4	oil pump bolts	10±1
5	driving bevel gear shaft cover bolts	9.5±2.5
6	oil sump bolts	9±1
7	speed sensor mounting bolts	8,5±2





## CVT Transmission

8	speed sensor bracket screws at differential	9.5±0.95
9	valve bolts	11±1
10	oil drain plug	11±1
11	driving model sensor mounting screws	9.5±0.95
12	oil level plug	15±2.25
3	gear selection lever nut	14.5±1.5



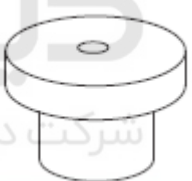



## (V) Maintenance Notice

Vehicle equipped with VT2 transmission can not be directly haul, because only when the engine is running the bevel gear can produce hydraulic, the strip can operate. Therefore, when haul the vehicle you have to lift the front wheel from the ground (vacant haul).

## (VI) Special tools

No.	Tool No.	Tool name	Tool figure	use
1	16G0049	Driving bevel gear bearing stopper		remove driving bevel gear bearing
2	16G0043	Selection gear shaft seal installation tool		Install the selection gear shaft seal
3	16G0050	Driving bevel gear bearing punch		Install driving bevel gear shaft ball bearing
4	16G0048	driving bevel gear bearing remove tool		remove the driving bevel gear bearing

## CVT Transmission

5	16G0041	input shaft oil seal install tool		install input shaft oil seal
6	16G0040	Input shaft seal bushing		install input shaft oil seal
7	16G0042	selection gear shaft seal remove tool		remove selection gear shaft seal
8	16G0046	Hydraulic control block locating pin		install hydraulic control block
9	16G0038	Differential oil seal installation tool		install differential oil seal
10	16G0045	Pump removal tools		remove pump
11	16G0044	Snorkel installation tool		install snorkel

## CVT Transmission

12	CVT-HDFJ-1	N gear assembly aid tool		Limit on the transmission shift rocker
----	------------	--------------------------	--	--

## II Troubleshooting

## ( I ) Troubleshooting sheet

No.	Fault phenomenon	Fault Analysis	Solution	Remark
1	Transmission oil pan gasket leak oil	oil sump bolts damaged	replace	
		oil sump washer	replace	
		oil drain hole	replace	
		oil sump assy	replace	
2	Transmission drain plug leak oil	bolts are not mounted tightly	retighten	
		Drain plug is damaged	replace	
		oil sump assy is damaged	replace	
3	driving bevel gear cover leak oil	sealed cover is not tighten	retighten	
		O-ring damage	replace	
		driving bevel gear cover damage	replace	
4	driven bevel gear cover leak oil	sealed cover is not tighten	Re-tighten	
		O-ring damage	replace	
		driven bevel gear cover damage	replace	
5	selector gear lever leak oil	selector gear lever washer damage	replace	
	input lever oil leakage	input shaft washer damages	replace	
	Differential oil seal leakage	seal damages	replace	



## CVT Transmission

6	Oil cooler interface oil leakage	lines are not tightened	tighten	
		oil cooler interface washer damages	replace	
		lines damage	replace	
7	Vehicle hashes when at D position, or hashes when quick acceleration	Self-learn is not fully completed	re-self learn	
		Fill the wrong gearbox oil or get in water	Replace the gearbox oil	
		Driving bevel gear speed sensor damages	replace	
		hydraulic control model fault	re-self learn	
		Driven bevel gear speed sensor damages	replace	
8	on D position, release the brake, the vehicle keeps stationary, then press the accelerator pedal, until the engine speed reaches about 2000 rpm, the vehicle suddenly rush out, accompanied by a great impact	Check the cold vehicle fault codes	According to fault codes diagnosis	
		Check the self-learning	re-self learn	
		Brake signal fault, when do not hit the braking pedal, the brake signal actually is in braking condition, cause this fault.	Check the brake signal and wiring harness	
		if there is no problem after check, it is maybe the valve problem	replace valve, and self-learning	

## (II) Noise description

## Driven bevel gear voice

There is significantly howling when accelerating at 60km/h-90km/h, release the accelerator pedal, the sound becomes smaller, depress the accelerator pedal, the sound immediately recovered.

Sounds like whistles, voice rises with increasing speed, the sound is normal voice. the sound is issued by the engagement of intermediate shaft gear and driven bevel gear.

## Reverse sound

Linked to reverse gear, keep the vehicle stationary, you can hear the small whistle sound.

This is a normal sound generated by transmission internal planetary gear.

## Low speed voice

When the speed at 40km / h, release the accelerator pedal, along with the speed is slowing down, you can hear a whistle. The whistles sound is smaller than the driven bevel gear and not easy to heard, this is a normal sound between the pinion and differential.

## CVT Transmission

## (III) Noise inspection and maintenance

No.	Fault phenomenon	Fault Analysis	Solution	Remark
1	Driving bevel gear ball bearing noise: Noise generated in the process of moving on D gear position, is buzzing sound, the sound volume and frequency rises along with the engine speed rises, do not rise with vehicle speed.	Drive at a constant speed on D gear position (at a constant throttle opening, the vehicle speed at about 60km / h) , then linked to S mode, the engine speed will increases about 500 rpm in 1-2 seconds, at the process, vehicle speed substantially unchanged, if the sound rises along with engine speed rises, that means the noise is generated by driving bevel gear ball bearing damaged.	Replace driving bevel gear ball bearing.	
		On 4 gear position at manual model, keep the throttle opening level, the vehicle speed maintains at a steady speed about 60km / h, then links to 3gear position, the engine speed will increase about 800 rpm, and then links from 3 to 4 gear position, the engine speed will reduces about 800 rpm, the speed remained unchanged throughout the process, if the sound rises along with engine speed rises, that means the noise is generated by driving bevel gear ball bearing damaged.	Replace driving bevel gear ball bearing.	
2	Transmission inner bearing noise: Noise generated in the process of driving on D gear position, is buzzing sound, the sound volume and frequency rises along with the vehicle speed rises.	According to the noise inspection method of driving bevel gear ball bearing, if noise doesn't rise along with engine speed rises, just rises along with vehicle speed, it maybe the wheel axle bearing noise, if the axle bearings troubleshooting, it is the internal gearbox bearing noise.	Correctly judge the noise problem is very difficult, so before deciding to replace the gearbox parts or replace the entire transmission, need to identify the noise is generated from the gearbox. Can replace some easily replaced parts on the car firstly, to determine the noise source.	Refer to transmission internal bearing noise chart.
3	Transmission water inlet noise: Linked on D or R gear position, slowly release the brake pedal, as long as the wheels move, it will generate giggle sound, depress the accelerator pedal, there would have squeak ----- consecutive sound at the speed between 10km / h to 40km / h, the noise disappear after vehicle exceed 40km / h. At the beginning of the water inlet, you may only hear "Kaka Lo" sound, can't hear "squeak -----" continuous sound when accelerating. Some cars may rush when started, this is based on the degree of water inlet.	Drain oil, remove oil sump and driving bevel gear cover. If the driving bevel gear inner cover have some white matters, and oil sump also has the same matters, this can sufficiently prove the transmission have water inlet, mixed with other oil or liquid.	Replace the new oil filter, re-fuel new transmission oil.	
		Driving at various speeds, acceleration and deceleration for about 5 minutes. "Kaka Lo "sound should disappear," squeak ----- "sound should be reduced.	Drain the transmission oil and refuel new oil.	
		"Squeak -----" sound can be solved by doing stall experiment to rise clutch temperature. links to D gear position, accelerates and depress the braking pedal tightly. If appears faulty code P2787 (clutch temperature is too high and off the clutch) at this process , this is just the transmission self-protection, not fault. after the faulty light	Replace transmission	

## CVT Transmission

		automatically turns off, can continue to do the stall experiment, until the noise disappears. Too much water or mixed with other oils, it does not solve the noise and rocky rush phenomenon.		
4	Neutral or P gear position noise (noise rises with the engine speed rises (accelerate at neutral position, sound bigger))	Judge the noise from engine or transmission, if come from the transmission parts, then check the oil pump abnormal noise.	Check the oil pump	
		If it is the transmission noise, and it's not the oil pump noise, it is maybe the input shaft bearing or planetary gear set noise.	Replace transmission	
5	Neutral or P gear position noise (noise doesn't rise with the engine speed rises.)	The noise comes from other parts of the vehicle, check the vehicle parts.	Correctly judge the noise problem is very difficult, so before deciding to replace the gearbox parts or replace the entire transmission, need to identify the noise is generated from the gearbox. Can replace some easily replaced parts on the car firstly, to determine the noise source.	Refer to neutral or P gear noise inspection flow chart.
6	Vehicle hashes when at D position, or hashes when quick acceleration.	Self-learn is not fully completed.	Complete self-learning	
		Fill the wrong gearbox oil or get in water, make the transmission oil go bad.	Replace transmission oil	
		Driving bevel gear speed sensor trouble.	Replace driving bevel gear speed sensor	
		Hydraulic control model (valve) trouble.	Replace hydraulic control model (valve)	
		Driven bevel gear speed sensor trouble.	Check the self-learning	
7	The vehicle can't move on D position, release the brake, the vehicle keeps stationary, then press the accelerator pedal, until the engine speed reaches about 2000 rpm, the vehicle suddenly rush out, accompanied by a great impact.	Check the vehicle there is a fault at the cold situation.	Check the self-learning	
		Brake signal fault, when do not hit the braking pedal, the brake signal actually is in braking condition, cause this fault.	Check braking signal and harness	
		If there is no problem after check, it is maybe the valve problem.	Replace valve and self-learning	

Transmission inner bearing noise flow chart

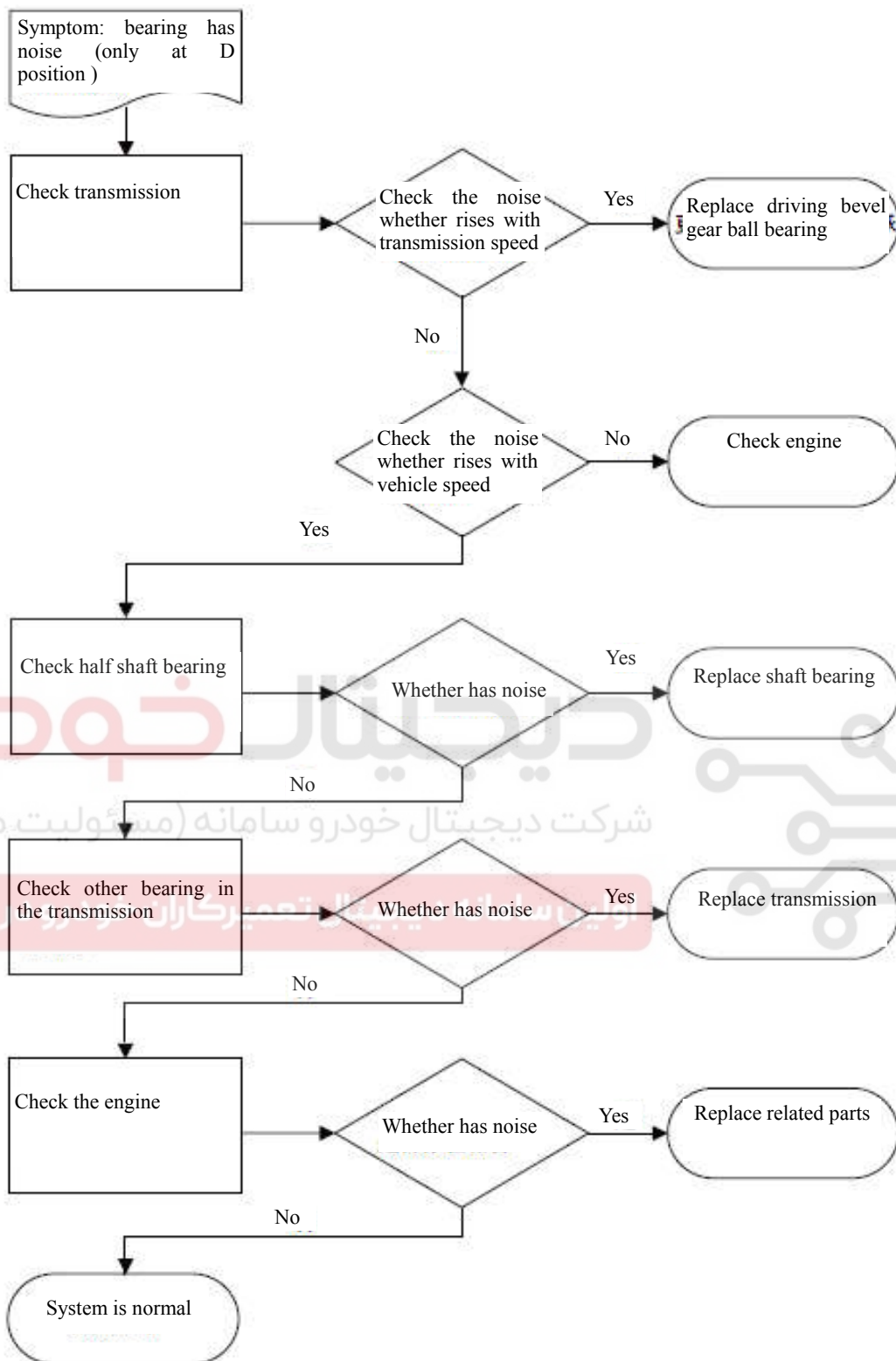

Neutral or P gear noise inspection flow chart

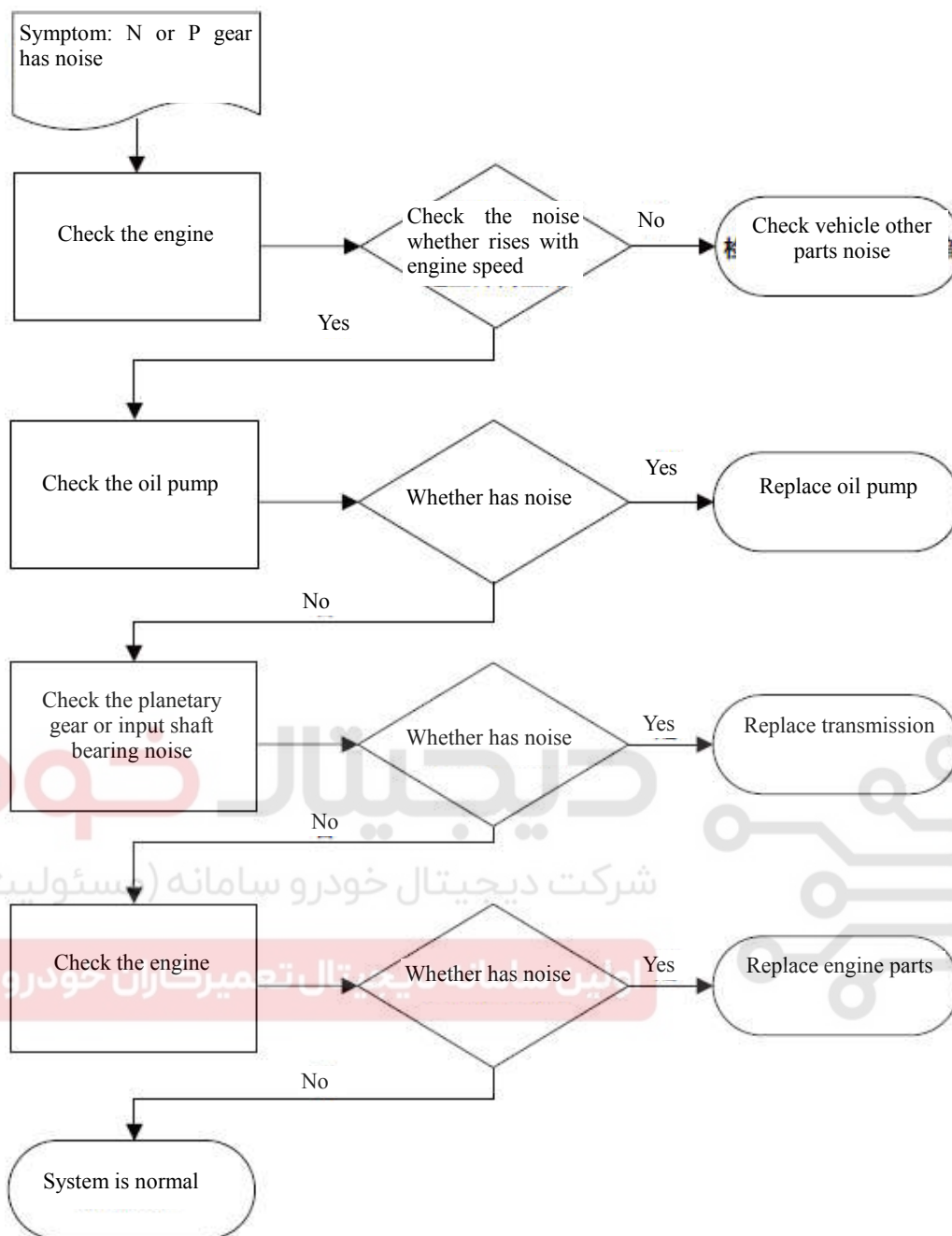

#### (IV) The fault code and measures

##### General Description

Once the gearbox control unit has fault code, fault light on the instrument panel will light up.

Whenever you check DTC fault code by inspection tool, first check the fault code is not a historic fault, and does not appear in the final drive period, if so, delete the fault code and check whether the fault code will reappear again. If the fault is not a historic fault, but a current fault, solve by the following fault code method.

Always check whether the latest software. If not, update to the latest software, and then check whether there is fault code.

General Description: Whenever there is fault code generated or transmission problems, first check the basic three:

- a. check whether is CVT special used oil
- b. check the oil lever
- c. re-self learning

Do not need to complete all of the following programs, if problem solved, there is not necessary to go deeper.

# دیجیتال خودرو

شرکت دیجیتال خودرو سامانه (مسئولیت محدود)

اولین سامانه دیجیتال تعمیرکاران خودرو در ایران



## CVT Transmission

No.	DCT code	TCU take measures	Maintenance guidance
1	P0710 oil temperature sensor trouble.	Fault indicator lighted, the system defines gearbox oil temperature.	Measure transmission oil temperature with a detector, if signal data is appropriate, clear fault code and check whether appear again.
			Check the harness (open circuit, short circuit, ground).
			Measure the resistance between the two gearbox main connector pins (when temperature at 20°C, the resistance should be between 980-1000 ohms) to determine whether the oil temperature sensor is damaged, if there is damaged, skip the next step and directly replace a main connector.
			Replace a new TCU.
2	P2765 driving bevel gear speed sensor trouble.	Three pressure regulators are power off, fault indicator lighted.	Replace transmission.
			Measure transmission oil temperature with a detector, if signal data is appropriate, clear fault code and check whether appear again.
			Check harness (short circuit, open circuit, ground).
			Replace a new TCU.
3	P0720 driven bevel gear speed sensor trouble.	Fault indicator lighted, the system defines driven bevel gear speed.	Replace speed sensor.
			Measure transmission oil temperature with a detector, if signal data is appropriate, clear fault code and check whether appear again.
			Check harness (open circuit, short circuit, ground).
			Replace a new TCU.
4	P0840 driven bevel gear pressure sensor.	Three pressure regulators are power off, fault indicator lighted.	Replace speed sensor.
			Measure the driven bevel gear actual oil pressure by the detector, and then compare with the target. if signal data is appropriate, clear fault code and check whether appear again.
			According to the first step of value test the circuit (ground: 0bar (actual pressure), short circuit: 60bar; breake circuit: 60bar).
			Replace a new TCU.
			Replace valve.

## CVT Transmission

5	P0641 pressure sensor power trouble.	Three pressure regulators are power off, fault indicator lighted.	Measure the input voltage whether is 5V, if data is appropriate, clear fault code and check whether appear again.
			Measure the voltage between sensor power wire and ground wire, based on the results in the first step.
			Check harness (short circuit, open circuit, ground ).
			Replace a new TCU.
			Replace hydraulic control model (valve).
6	P0651 driving model sensor and speed sensor power trouble.	Three pressure regulators are power off, fault indicator lighted.	Measure the input voltage whether is 5V, if data is appropriate, clear fault code and check whether appear again.
			Measure the voltage between sensor power wire and ground wire, Based on the results in the first step.
			Check harness (short circuit, open circuit, ground).
			Replace a new TCU.
7	P0659 pressure regulator short circuit.	Three pressure regulators are power off, fault indicator lighted.	Compare the measured voltage of HS and battery.
			If the same, inspect the circuit (check short circuit between the battery positive and VHS and transmission) and fix the wiring harness.
			If different and more than 3.4V, then replace TCU.
8	P0658 pressure regulator is open circuit or grounded.	Three pressure regulators are power off, fault indicator lighted.	Compare the measured voltage of HS and battery.
			If battery voltage is normal, high end voltage is less than 3.4V, it means some wires are grounded.
			If battery voltage is normal, high end voltage is more than 3.4V, it means some wires are open circuit.
			For these two situation, check the PIN wire according to the fact, if the wire is good , then replace the TCU.
			If the battery voltage is abnormal, check the battery.
9	P0702 TCU inner inspection system fault.	Three pressure regulators are power off, fault indicator lighted.	Replace TCU.



## CVT Transmission

10	P0962 EDS1 driving bevel gear pressure regulator is grounded.	Three pressure regulators are power off, fault indicator lighted.	Measure the of driving bevel gear regulator, it should be $5.05\Omega \pm 6\%$ .
			Check the wire(ground), replace the transmission inner wire or engine wire according to inspection result.
			Replace hydraulic control model.
11	P0963 EDS1 driving bevel gear pressure regulator is short circuit.	Three pressure regulators are power off, fault indicator lighted.	Measure the resistance of driving bevel gear pressure regulator.
			Check wire (open circuit), replace the transmission inner wire or engine wire according to inspection result.
			Replace hydraulic control model.
12	P0966 EDS2 driven bevel gear pressure regulator is grounded.	Three pressure regulators are power off, fault indicator lighted.	Measure the resistance of driven bevel gear pressure regulator.
			Check the wire(ground), replace the transmission inner wire or engine wire according to inspection result.
			Replace hydraulic control model.
13	P0967 EDS2 driven bevel gear pressure regulator is short circuit.	Three pressure regulators are power off, fault indicator lighted.	Measure the resistance of driven bevel gear pressure regulator.
			Check wire (short circuit), replace the transmission inner wire or engine wire according to inspection result.
			Replace hydraulic control model.
14	P0964 EDS2 driven bevel gear pressure regulator is open circuit.	Three pressure regulators are power off, fault indicator lighted.	Measure the resistance of driven bevel gear pressure regulator
			Check wire (open circuit), replace the transmission inner wire or engine wire according to inspection result.
			Replace hydraulic control model.
15	P0902 EDS3 clutch pressure regulator is grounded.	Three pressure regulators are power off, fault indicator lighted.	Measure the resistance of clutch pressure regulator.
			Check the wire(ground), replace the transmission inner wire or engine wire according to inspection result.
			Replace hydraulic control model.
16	P0903 EDS3 clutch pressure regulator is short circuit.	Three pressure regulators are power off, fault indicator lighted.	Measure the resistance of clutch pressure regulator.
			Check wire (short circuit), replace the transmission inner wire or engine wire according to inspection result.
			Replace hydraulic control model.

## CVT Transmission

17	P1763 starter lock is grounded or short circuit.	Three pressure regulators are power off, fault indicator lighted.	Check wire, if gear position sensor has problem, it also has this fault code.
			Replace TCU.
18	P1764 starter lock is short circuit.	Three pressure regulators are power off, fault indicator lighted.	Check wire.
			Replace TCU.
19	P1768 reverse indicator lighter is grounded.	Three pressure regulators are power off, fault indicator lighted.	Check wire.
			Replace TCU.
20	P1769 reverse indicator lightor is short circuit or open circuit.	Three pressure regulators are power off, fault indicator lighted.	Check wire.
			Replace TCU.
21	P0868 pressure pre-tighten adjust fault.	Three pressure regulators are power off, fault indicator lighted.	Check the oil lever and oil quality.
			Replace oil pump.
			Replace hydraulic control model.
			Replace transmission.
22	P0811 clutch slips (forward or reverse).	Fault indicator lighted, clutch open.	Re-self learning, this fault code is likely to occur at the cold vehicle situation, so do self-study in the cold vehicle situation.
			Check the oil lever and oil type.
			Replace hydraulic control model.
			Replace transmission.
23	P0730 transmission ratio control fault.	Three pressure regulators are power off, fault indicator lighted.	Inspect the output signal of speed sensor, and inspect the input and feedback current of driving bevel gear pressure regulator.
			Take appropriate measures on the basis of failure, such as if there is a problem with the speed sensor checks the speed sensor, if there is problem with pressure check pressure sensor.
			Check the oil lever and oil type.
			Replace oil pump.
			Replace hydraulic control model.
			Replace transmission.
24	Driven bevel gear pressure is too low.	Three pressure regulators are power off, fault indicator lighted.	Measure in dynamic driving situations (like the manual shift mode, etc.) to compare the actual and the target pressure.
			Check the oil lever and oil type.

## CVT Transmission

			<p>Completely self-study (fault code may occur in the case of self-study is not completed).</p> <p>Check the engine side reason which can cause the engine torque reduction: spark plugs, throttle, catalytic, etc. (the longer the engine use, the more this problem may occur).</p> <p>Replace hydraulic control model.</p> <p>Replace oil pump.</p> <p>Replace transmission.</p>
25	P1766 driven bevel gear pressure is too high.	Fault indicator lighted.	<p>Measure in dynamic driving situations (like the manual shift mode, etc.) to compare the actual and the target pressure.</p> <p>Check the oil lever and oil type.</p> <p>Replace hydraulic control model.</p> <p>Replace oil pump.</p> <p>Replace transmission.</p>
26	P0701 Two faults occur at the same time require pressure regulator power off.	Fault indicator lighted.	<p>Check others fault code.</p> <p>Check oil cooler.</p>
27	P0218 transmission oil is too high.	Fault indicator lighted.	<p>Try to reappear the fault under normal driving conditions again, if you don't appear, ask customers for this failure occurred under what driving conditions.</p> <p>At step 2 driving conditions, the gearbox oil temperature can be measured, check the gearbox oil temperature whether <math>\geq 120</math> °C by detector (if the DTC appear time shorter than filter 30 minutes is not right) take measures to avoid transmission occurs over-temperature.</p>
28	P1767 Transmission oil temperature is out of range.	Three pressure regulators are power off, fault indicator lighted.	<p>Try to reappear the fault under normal driving conditions again, if you don't appear, ask customers for this failure occurred under what driving conditions.</p> <p>Check oil cooler.</p> <p>Check the oil lever.</p> <p>Replace valve.</p> <p>Replace transmission.</p>

## CVT Transmission

29	P0219 Power system speed is out of range.	Three pressure regulators are power off, fault indicator lighted.	Generally speaking, it would never appear. Check the engine speed whether is limited to less than 6000rpm.
30	P2766 Driving bevel gear rotate speed doesn't match the real rotate speed.	Three pressure regulators are power off, fault indicator lighted.	<p>Check other parts speed information by detector (engine rpm output shaft rpm, vehicle speed)whether is also lost; if it is, solve these problems first and then check whether the fault occurs again.</p> <p>Measure the driving bevel gear RPM signal with detector,compare with the engine RPM in the clutch engaged situation, the difference should be less than 200 rpm.</p> <p>Check the circuit.</p> <p>Replace a new TCU.</p> <p>Check sensor's position and angle, RPM sensing plate should also be checked. Check whether there are no materials in front of the sensor (the strip chip, etc.) Note: This is a mechanical failure, electrical failure has other DTCs.</p> <p>Replace driving bevel gear speed sensor.</p> <p>Replace the transmission inside harness.</p> <p>Replace engine harness.</p> <p>Replace transmission.</p>
31	P0721 Driven bevel gear RPM doesn't match the real RPM.	Fault indicator lighted. Increase the clamping force to 0 level, the system would define driven bevel gear RPM.	<p>Check other parts speed information by detector (engine rpm output shaft rpm, vehicle speed)whether is also lost; if it is, solve these problems first and then check whether the fault occurs again.</p> <p>Measure the driving bevel gear RPM signal with detector,compare with the engine RPM in the clutch engaged situation, the difference should be less than 200 rpm. Should compare at all speed range, from low to high (up to 6000 rpm).</p> <p>Check the circuit.</p> <p>Replace a new TCU.</p> <p>Check sensor's position and angle, RPM sensing plate should also be checked. Check whether there are no materials in front of the sensor (the strip chip, etc.) Note: This is a mechanical failure, electrical failure has other DTCs.</p>

## CVT Transmission

			Replace driving bevel gear speed sensor.
			Replace the transmission inside harness.
			Replace engine harness.
			Replace transmission.
32	P0944 Clamping force is insufficient (VSM)	Fault indicator lighted. Increase the clamping force to 0 level, the system would define driven bevel gear RPM.	Check the ECU DTC. Replace ECU Check the oil lever and quality. Completely self-study (fault code may occur in the case of self-study is not completed). Check the engine side reason which can cause the engine torque reduction: spark plugs, throttle, catalytic, etc. (the longer the engine use, the more this problem may occur). Replace valve. Replace oil pump. Replace transmission.
33	P0782 Winter driving mode fault.	Fault indicator lighted, the system defines winter mode closed.	Check the circuit. Replace ECU.
34	P0783 Cruise control fault.	Fault indicator lighted, the system defines cruise control function mode closed.	Check the circuit. Replace ECU. Replace TCU.
35	P0810 Offline adaptive update unfinished.	Fault indicator light flashes.	Do adaptive update once again.
36	P1762 Current value is fixed and can not be changed.	Three pressure regulators are power off, fault indicator lighted.	Check the P0962, P0963, P0960, P0966, P0967, P0964, P0902, P0903, P0900, P1763, P1764 DTC and fix them, there may be no DTC. Replace a new TCU.
37	P0882 Battery or high end voltage is too low.	Three pressure regulators are power off, fault indicator lighted.	When this failure occurred there would have a record of the battery voltage at that time (so it is not possible to identify whether high end or battery voltage fault caused); if no history, direct exam next.

## CVT Transmission

			<p>Measure the voltage of high end and battery by detector, Temperature would have greater impact on the value: detailed information refer to Software Content.</p> <p>Check the circuit from the battery to TCU (fuse, main relay).</p> <p>Replace / Check battery.</p> <p>If it is the high - end voltage problem: check the circuit from the gearbox to the TCU.</p> <p>Replace TCU.</p>
38	P0883 Battery or high end voltage is too high.	three pressure regulators are power off, fault indicator lighted.	<p>When this failure occurred there would have a record of the battery voltage at that time (so it is not possible to identify whether high end or battery voltage fault caused); if no history, direct exam next.</p> <p>Measure the voltage of high end and battery by detector, Temperature would have greater impact on the value: detailed information refer to Software Content.</p> <p>Check the circuit from the battery to TCU (fuse, main relay).</p> <p>Check/replace battery or generator.</p> <p>If it is the high - end voltage problem: check the circuit from the gearbox to the TCU.</p> <p>Replace TCU.</p>
39	P2787 Clutch temperature is too high.	Fault indicator lighted, clutch open.	<p>Check this failure occurred how many times, if only once or a few times, then take a look inside TCU data and ask the customer whether had a special driving environment, such as climbing lane, if so, you can delete DTC.</p> <p>Check the oil lever and quality.</p> <p>Completely self-study (fault code may occur in the case of self-study is not completed).</p> <p>Only in doing the stall test it would appear this DTC , delete DTC, check whether re-occur.</p> <p>Replace TCU.</p> <p>Maybe the throttle is stuck, replace the throttle.</p>

## CVT Transmission

40	P0727 The hard-wire from the ECU to the TCU engine RPM doesn't match with actual RPM.	Fault indicator lighted.	Check engine test report to see whether if the engine failure, if it is, repair the engine.
			Inspect ECU input signal - this is a frequency signal (900 rev / min is 30Hz, 3000 rev / min is 100Hz).
			Replace TCU.
			Replace engine speed sensor.
41	P1761 Pressure regulator current fault.	Three pressure regulators are power off, fault indicator lighted.	Measure the pressure drop of pressure regulator by detector, and compare with every pressure regulator specified current.
			Measure the current of pressure regulator and compare with specified current, If you find that one is different from specified current, check the pressure regulator wire (also check the inside gearbox wire).
			Replace TCU.
			Replace hydraulic control model.
			Replace the transmission inside harness.
			Replace engine harness.
42	U0301 Vehicle configuration error (such as use other car's ECU).	Three pressure regulators are power off, fault indicator lighted.	Check the TCU's hardware and software combination is correct and effective.
			If EMS or TCU newly upgrade software: new software on the controller must be wrong (transmission controller and engine controller is incompatible).
43	P0706 Driving mode sensor single line error.	Fault indicator lighted, the system defines sensor position.	Check with detector which lines have problem, what is the problem, such as B-line short-circuit and so on (this Fault showed one line has a faulty).
			Check the related wire between the gearbox and the TCU.
			Replace a new TCU.
			Replace driving mode sensor.
			Replace the transmission inside harness.
44	P0705 Driving mode sensor multi-line error.	Three pressure regulators are power off, fault indicator lighted.	Check with detector which lines have problem, what is the problem, such as B-line short-circuit and so on (this Fault showed one line has a faulty).
			Check the related wire between the gearbox and the TCU.

## CVT Transmission

			Replace a new TCU.
			Replace driving mode sensor.
			Replace the transmission inside harness.
			Replace engine harness.
45	P0571 Brake signal fault.	Fault indicator lighted, brake signal engaged.	Check the brake signal status with the detector.
			Check the brake signal harness.
			Check the brake switch.
			Replace TCU.
46	P0955 Manual gear acceleration signal fault.	Fault indicator lighted, no manual mode.	Check the circuit between TCU and gear shift.
			Replace gear shift mechanism.
			Replace a new TCU.
47	U0001 CAN bus fault.	Fault indicator lighted, emergency mode is activated, no manual mode. Increase clamping force level 1 (highest), system defines locking and rotation status, activate internal drive strategy, system defines engine speed and engine torque, system defines engine cooling water system, the brake signal engages, the accelerator pedal digital fixed, system defines all the four wheels' RPM.	If the fault occurs in all other controllers, it means the problem is the wiring harness (CAN high speed and low speed short-circuit): check the car harness.  If the fault is only stored in TCU: replace a new TCU.
48	U0121 ABS CAN communication fault.	Fault indicator lighted, emergency mode is activated, no manual mode. Increase clamping force level 0, system defines locking and rotation status, system defines all the four wheels' RPM.	Check the CAN communication connectors on the ABS controller box (perhaps it would also report this Fault on the other controllers).
49	U0100 ECU CAN communication fault.	Fault indicator lighted, emergency mode is activated, no manual mode. Increase clamping force level 0, activate internal drive strategy, system defines engine torque, system defines engine cooling water system, the accelerator pedal digital fixed, stop data transfer on the CAN.	Check the CAN communication connectors on the ABS controller box (perhaps it would also report this Fault on the other controllers).



## CVT Transmission

50	U1012 CAN bus engine speed signal fault.	System defines engine RPM.	Check the MCU controller (engine speed sensor and sensor wiring).
51	U1013 CAN bus accelerator signal fault.	Fault indicator lighted, fixed value of the accelerator pedal.	Check the EMS controller (accelerator pedal sensor and sensor wires)
52	U1014 CAN bus engine torque signal fault.	Fault indicator lighted, emergency mode is activated, no manual mode, activate internal drive strategy, system defines engine torque.	<p>Check the EMS controller.</p> <p>Note: three pressure regulators power off: When have DTC and pressure regulator power off, the clutch open, the car can not go forward even in gear. Only power off the engine and re-ignition, the car can continue to work.</p> <p>Increase clamping force level 0: driven bevel gear pressure is fixed, the pressure is higher than normal condition, lower than the highest level.</p> <p>Increase clamping force level 0: driven bevel gear pressure is fixed at highest level.</p> <p>EDS1 driving bevel gear pressure regulator.</p> <p>EDS2 driven bevel gear pressure regulator.</p> <p>EDS3 clutch pressure regulator.</p> <p>Emergency Mode: also called lameness home mode, when one of the following cases is activated:</p> <p>CAN bus falls off.</p> <p>CAN ECU communication fault.</p> <p>CAN bus engine torque signal fault.</p> <p>All engine and ABS related signals will be replaced (safety measures):</p> <p>Throttle opening degree is fixed.</p> <p>Engine MAP figure replace the engine torque.</p> <p>Engine cooling temperature is fixed.</p> <p>Wheel speed is replaced by the gearbox output shaft speed.</p> <p>Engine speed uses the speed signal passed by video wire.</p> <p>The engagement and separation of the clutch is very rigid, as if there is no calibration data in it.</p> <p>The maximum engine speed is limited to 3200 rpm.</p> <p>The maximum speed is limited to 98km / h.</p> <p>Transmission will be shifted in a acceleration strategy.</p> <p>CVT will only work in the most basic conditions, provide adequate driving performance to make the car drive to a nearby service station.</p> <p>After two seconds, manual or sports gear can't use, and fault indicator turns on.</p>

### III Driving strategy

#### ( I ) Parking and neutral gear functional properties

No matter what transmission, the engine can be started only in the parking or neutral gear. Mechanical lock at the parking gear can make the car never move around. It's better to use parking gear when vehicle in the stationary state, to prevent damaging the transmission.

If you carelessly use the parking gear at high speed, mechanic lock will work only after the speed is slow down to 5km / h.

##### Parking lock mechanism

When start the vehicle, TCU will control the starter relay, starter relay will control starter motor.

Car gear is controlled by the internal driving mode sensor, and driving mode sensor directly connects to the gear shift lever.

If you want to shift from parking gear (P) or neutral gear (N) to forward gear (D) or reverse gear (R), you need to depress the brake pedal. If you do not depress the brake pedal, gear lever is still locked at the P or N gear.

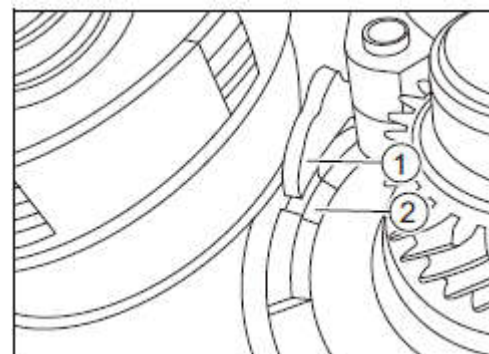

1. parking detent pawl
2. driven bevel gear

#### ( II ) D or R gear function

##### Regular operation

When driving the vehicle, the operation of this transmission is completely different from the traditional transmission, so you need to pay attention to adapt. For example: when depresses the accelerator pedal fastly, the engine speed will significantly rise, but the vehicle speed will change little. This phenomenon is normal for a continuously variable transmission, if the driver did not understand this, he may (mistakes for a gearbox failure).

Other approximate situation with the traditional automatic transmission may also exist.

##### Adaptive update

Either forward or reverse, the clutch has to be re-calibrated accordingly, to achieve the best performances in its lifetime.

##### Crawl

According to the automatic transmission performance, when the gear shift lever is in forward gear (D) or reverse gear (R), if the driver release the brake pedal, the car begin to crawl (flat road). If the road surface gradient is less than 8 °, car will crawl; if the road surface gradient is greater than 8 °, Car will be slightly back, like car equipped torque converter transmission, it wouldn't back if the gradient is not great. No matter the road surface gradient, the maximum vehicle crawling speed will be less than a limit value (e.g. 8kph). Especially when going downhill, the control system will change the clutch from separation to engagement mode, so that we can use the engine brake in the downhill.

##### Idling stop (only forward gears status)

VT2 transmission can achieve idling stop. Vehicles (battery status, air conditioning on / off) and the transmission terminal (does not affect the durability of the transmission) can achieve the idling stop under some certain conditions. If all conditions are satisfied, the engine power off in stationary state. Only release the brake pedal, the engine restarts, transmission work quickly, the vehicle can move again.

The idling stop function is particularly suitable for a hybrid power transmission device, but for standard power transmission device without special starters or start motors, the idling stop function is useless.

##### Acceleration and deceleration

Acceleration process is mainly based on the driver's request and driving conditions to provide acceleration, at the time the engine speed change trend corresponds with initial speed, which can achieve optimum driving comfort.

## CVT Transmission

Clutch controller also provides some methods to compensate the difference caused by clutch wear (it's difference between different vehicles), thus ensuring driving comfort.

### Acceleration support

To achieve the optimum driving comfort, we should determine the most appropriate engine speed, the rotation speed between the minimum tractive force engine speed and the vehicle maintain the constant velocity (economic speed) cruising engine speed.

Transmission control system through the federated control mode between transmission (ratio control) and starting clutch provides functionality to meet these requirements. Thus, when starting the vehicle, the control target focuses on the control associated with the acceleration of the high engine speed driving performance, and when the vehicle is cruising or coasting, the control target changes to the the fuel economy.

### Deceleration

If the driver depresses on the accelerator pedal and brake pedal at the same Time, the engine speed will be limited within a certain range (similar with torque converter transmission ). To this end, the transmission and engine control systems need to block torque together, so if the driver suddenly releases the brake pedal, the transmission can react quickly to control the clutch.

Long-term use can cause clutch high temperature consumption, the transmission also has damage risk, so we use the monitoring capability to detect these dangerous conditions. activate transmission internal diagnostic system, can open the clutch. Then if the driver has been depressing on the accelerator pedal, the engine will accelerate to maximum rotation speed. And in other cases, clutch controller can follow the highest control objectives to ensure intrinsic safety, improve driving comfort.

### Driving and braking

When the car decelerates to a standstill, the clutch separated again to prevent engine stalling, control the clutch pressure steady decline, the clutch gradually separated, and therefore does not cause torque fluctuations. Therefore, the controller provides different modes to make the clutch separate according to the speed change. Clutch pressure control device can also according to the lubricating oil temperature of the transmission control hydraulic control system power. the clutch quickly prepare starting after release.

In order to make the best vehicle driving comfort at the starting and braking process, transmission software works together with other transmission control devices, this action causes temporary interruption of torque transmission, idling increases.

### Clutch engagement / separation while driving

If the driver does not use the clutch, the transmission controller has little effect on driving comfort, because if don't use clutch there would have no relationship with the hydraulic system characteristics. In this case (Low load, parking, low engine speed) compared with the application again and the stationary state application, driving comfort may decline.

### (III) the fault default mode

When the software detects a system error, the default mode will be applied; and this will be transferred to the drive through the instrument fault display. The drive will take different default driving state in accordance with the severity of the error. In some cases, the main relay opens. All fault codes will appear on the OBD.

## IV Adaptive update

### ( I ) Explanation

The following conditions need to be adaptive learning:

- ECU updates software TCU
- replace transmission

· replace TCU

Clutch need to do to adaptive update (self-learning) to compensate tolerances from the production process.

By shift at the idle condition to achieve this functionality.

Before self-learning doesn't completed, TCU malfunction indicator light flashes once every two seconds.

Once the first time study is completed, all the self-learning are done automatically in the following entire life cycle.

## (II) The required condition

This condition needs to be completed before the self-learning: need stable engine torque and speed under idle status, the engine also needs to complete the self-learning ahead, for more engine self-learning information, please refer to ECU (the suppliers' documents. Engine speed requirement: ECU target value  $\pm 200$ rpm · engine torque requirement: ECU target value  $\pm 12$ N · m · Transmission temperature should between 30 °C to 80 °C. Air conditioning is off \* A non-adaptive X CTU will always issue a request to the idling engine rose to 1150rpm. If the X CTU done self-learning before, which include: 1. Update the software 2. Replace the gearbox. TCU first need to delete the self-learning value. MLT software can solve or manufacturer's detector can solve.

## (III) Program

After we all fulfill all the conditions, we execute the following operations:

- Speed = 0 kph · don't depress the accelerator pedal
- depress the brake pedal at the whole process
- Switching gears to the "D"

دیجیتال خودرو

شرکت دیجیتال خودرو سامانه (مسئولیت محدود)

اولین سامانه دیجیتال تعمیرکاران خودرو در ایران



CVT Transmission

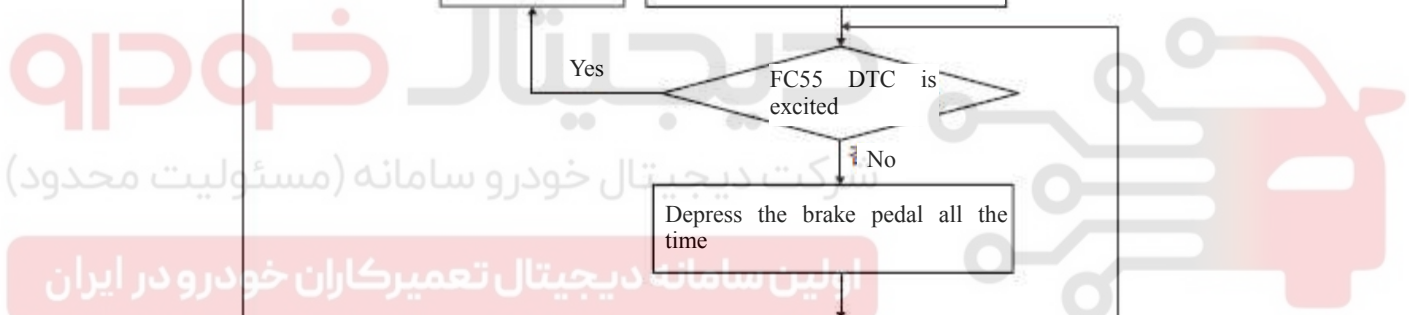
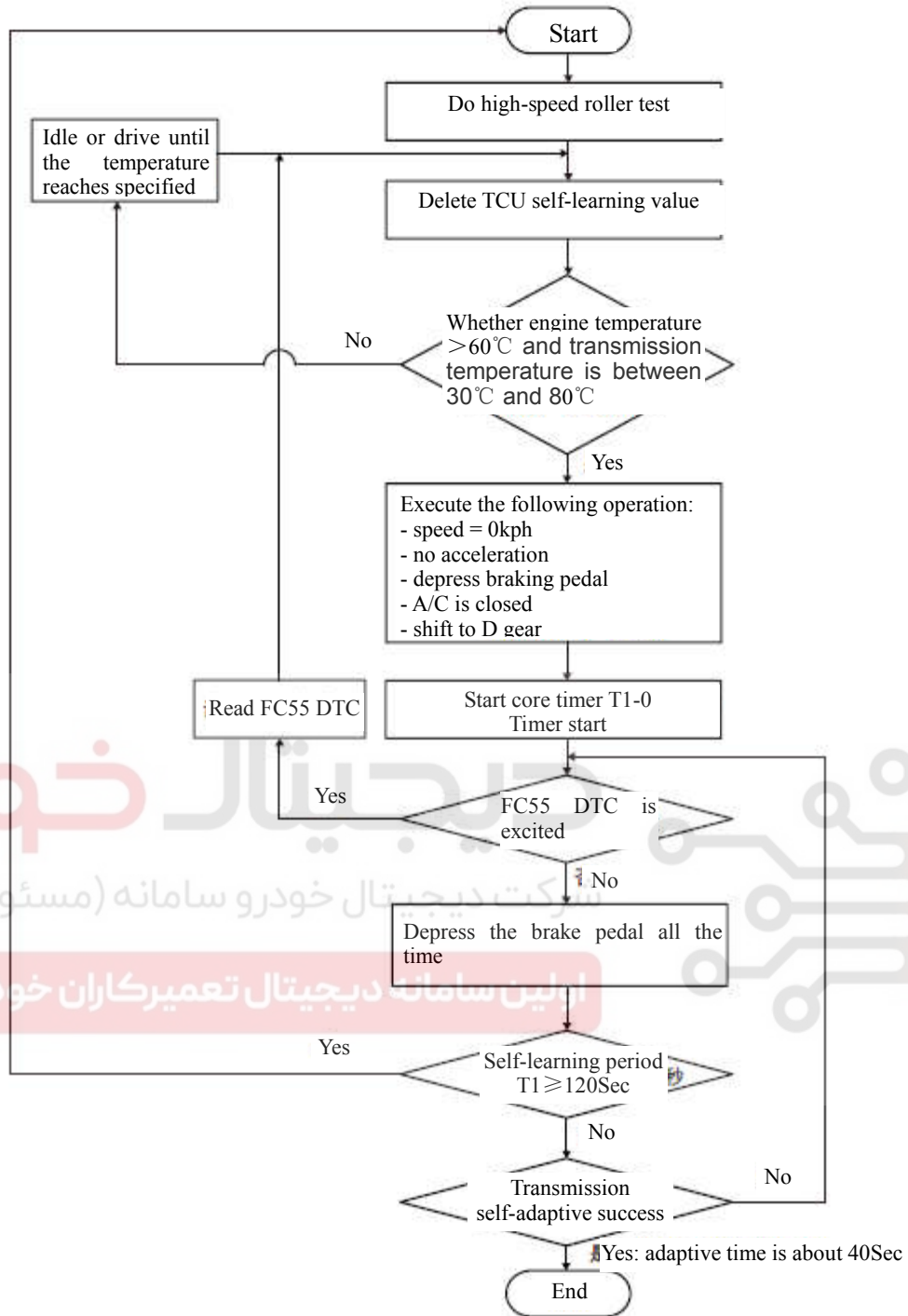

CVT Transmission

Clutch adaptive program will start automatically. In the learning process, if there some cases interfere adaptive learning, fault codes FC55 (P1774) will be excited, then the fault light will stay on for warning. As long as the clutch self-learning is not completed, the fault code FC51 (P080A) will be excited out. At the same time, the fault lamp flashes.

When everything goes well, complete the gear adaptation time is about 40s. If it has not been completed within 120s, then the adaptive program will fail.

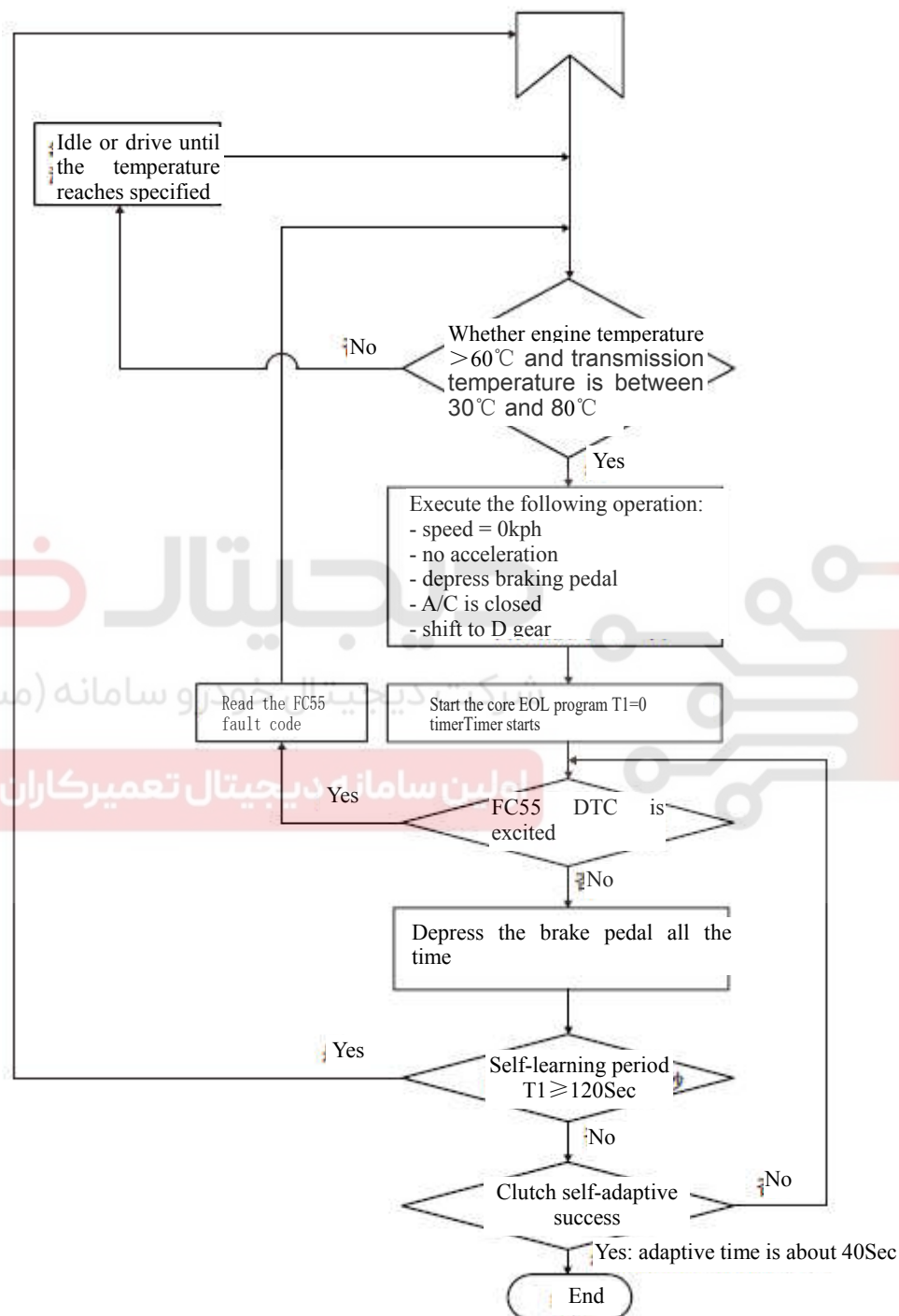

When at this gear, after the clutch adaptive program is completed, engine speed will increase to 1500rpm again in a short time, then we can continue the next step.

Note: For after sale vehicle, does not require high-speed roller test.

Be sure to double-check all prerequisites for self-learning has been completed.

Please follow the steps below:

- Speed = 0 kph
- Release accelerator pedal

## CVT Transmission

- Keep depress the brake pedal all the process
- Switching gears to the "R"

Offline clutch adaptive program will start automatically. In the learning process, if there are some cases that interfere with adaptive learning, fault codes FC55 (P1774) will be excited, then the fault light will stay on for warning. As long as the clutch self-learning is not completed, the fault code FC51 (P080A) will be excited out. When everything goes well, complete the adaptation time is about 40s. At the same time, the fault lamp flashes. If it has not been completed within 120s, then the adaptive program will fail. After the clutch adaptation is successful, the engine speed will increase to 1500rpm in a short time and then suddenly drop to idle speed (850rpm), this time a transmission fault light will automatically turn off.

Remark:

First in the D gear and then into the R gear, this order is not mandatory. Similarly hang R gear and then into the D gear, such adaptive order is no problem.

## (IV) Frequently Asked Questions

Clutch self-learning error code	Type
1	Engine torque is unstable
2	Air conditioning is in the open state
4	Pressure is too high
8	engine speed is too low
16	engine speed is too high
32	Too frequent failure

Problems	Possible reasons	Solutions
Self-learning fails over 120s	The transmission oil temperature is below 30 °C at the learning process	Start the engine, let the oil temperature rise above 30 °C, self-learning again.
	The transmission oil temperature is above 80 °C at the learning process	Turned off the engine until the oil temperature reduced below 80 °C, self-learning again.
	The engine temperature is below 60 °C at the learning process	Start the engine, let the oil temperature rise above 60 °C, self-learning again.
	There was release brake pedal loose case at the learning progress	Self-learning again to ensure that depress the brake pedal tightly all the time.
FC55:offline adaptive fault code is 1	Engine torque is unstable	Increase the engine torque smoothly, ensure successfully complete the self-learning.
FC55:Clutch self-learning error code is 2	Air conditioning is turned on	Turn off air conditioning, self-learning again.

## CVT Transmission

FC55:offline adaptive fault code is 4	Clutch pressure rises, but engine torque does not improve	Links into D or R gear, check the transmission torque transmission is normal, check the engine torque signal is normal, self-learning again.
FC55:offline adaptive fault code is 8	Engine speed is too low	Increase the engine speed smoothly, self-learning again.
FC55:offline adaptive fault code is 16	Engine speed is too high	Increase the engine speed smoothly, self-learning again.
FC55:offline adaptive fault code is 32	Torque abnormal,. whether the switch is activated etc	Confirm all auxiliary functions are not used, after confirming, re-learning.

## V Transmission oil

## ( I ) Special tools (none)

## ( II ) Oil level examination description

Whenever replace the gearbox oil, or replace the new gearbox, oil level must be checked as follows.

As spare part, the gearbox has no oil, should add about 4.15 liters of ESSO EZL799 (A) after assembly.

Check the oil level in accordance with the following method after refueling:

- 1) Start the engine and idle at least 10 seconds (Note: When starts the engine hear air flow voice circulates in the system is normal).
- 2) Switch shift lever to different gear (parking-reverse-neutral-Drive) and stay at least 5 seconds on each gear before switching to the next gear.
- 3) Shift to the "D" (Drive).
- 4) Release brake pedal.
- 5) Accelerate over 60 km / h (engine speed is not higher than 2500 rpm).
- 6) Release the accelerator pedal, slowly to the stopping (all the noise caused by air circulation when start will disappear).
- 7) Heat up the oil, drive carefully at least 5 minutes or until the transmission oil temperature reaches about 60 ° C.
- 8) Park the car on flat ground.
- 9) Depress brake pedal.
- 10) Wait 2 seconds.
- 11) Shift to R (reverse gear).
- 12) Release brake pedal.
- 13) Wait 10 seconds.
- 14) Depress brake pedal.
- 15) Shift to N (parking gear).
- 16) Keep the engine idling.
- 17) The engine idle operation.
- 18) Loosen oil lever plug.
- 19) After loosen the oil lever plug, there will at least 0.2 liters flow out from the tube. (Otherwise prove initial oil is inadequate) if less than 0.2 liters, plus 0.5 liters oil, and then re-do the above process again.
- 20) Until the oil starts to drip from the oil level plug mouth.
- 21) Retighten the oil level plug with new gasket (torque: 18 ~ 24N · m).
- 22) the engine.



23) Shift to P (parking gear).

(III) Oil level examination

If the initial filling is correct, the oil level should be at the correct position (at the position of the oil level plug).

Normal tolerances position (like new gearbox residual oil and production line filling tolerance) should the oil level plug, the oil level can be  $\pm 0.165L$ .

1. Check the transmission oil level

- 1). Remove the gearbox upper filling bolts.
- 2). Fill accurate 0.5L oil to the transmission.
- 3). Install the filling plug. Tightening torque  $18 \sim 24N \cdot m$ .
- 4). Start the engine, heat up the gearbox temperature to about  $60^{\circ}C$ .
- 5). Park the car on flat ground.
- 6). Depress brake pedal, wait for 2 seconds before shift to P gear.
- 7). Keep the engine idling operation.
- 8). Remove the oil level plug in the engine idling conditions.
- 9). Correctly drain oil (at least 0.335L, up to 0.665L).

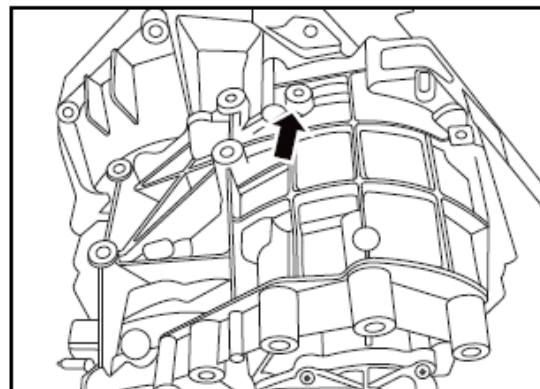

Minimum  $0.235L$  ( $0.5 \text{ ADDED oil} - 0.165 \text{ tolerances} - 0.1L = 0.235L$ ) oil will outflow from the gearbox, if less than this amount, the original oil level is too low.

Maximum  $0.565L$  ( $0.5 \text{ ADDED oil} + 0.165 \text{ tolerances} - 0.1L = 0.565L$ ) oil will outflow from the gearbox, if more than this amount, the original oil level is too high.

△Note: All data are derived from the gearbox oil temperature is  $60^{\circ}C$ .

- 10). Install a new gasket, tighten the oil level plug.

Tightening torque  $18 \sim 24N \cdot m$

- 11). Turn off the engine.

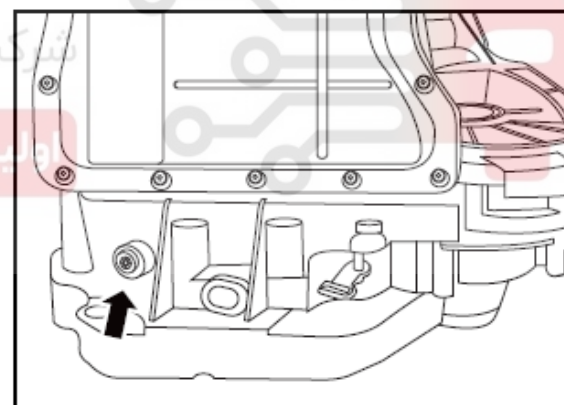

VI Shift lever assembly

( I ) Special tools

1	CVT-HDFJ-1	N gear assembly aid tool	
---	------------	--------------------------	--

## CVT Transmission

## ( II ) Remove

## 1. Remove shift lever assembly

- 1). Shift the gear lever on P.
- 2). Remove the worm at a place (use screwdriver or opening wrench).
- 3). Then loosen the nut at the b place.

Note: when loosen the nut, the transmission shift rocker may move at the same time, then need to recover to the initial position immediately after release (basic transmission shift rocker normally straight down).

- 4). Remove shift lever assembly.

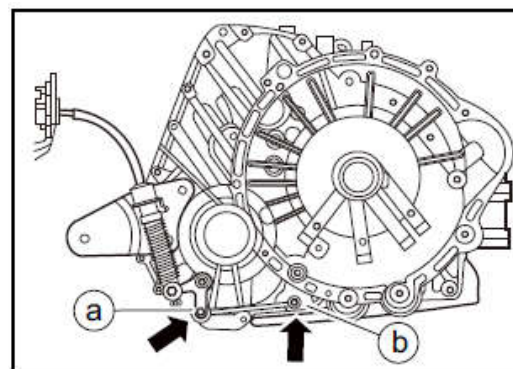

## ( III ) Assembly

## 1. Assemble shift lever assembly

- 1). Mount the new shift lever on the gearbox.
- 2). Switch the shift lever shift back and forth for five times, and then shift to the N.
- 3). Press the gear shift rocker ball at a position into the worm.
- 4). Chucking the the transmission gear shift rocker by aids tool, then tighten the

nut at b position.

△notice: Aid must be fully snap to the position as "aid assembly and adjustment chart "shown, to ensure its limit slot is fully contacted with transmission shift rocker plane, against aids handle by hand at the nut tighten process, try to make the transmission shift rocker don't move or shake.

Tighten torque 20 ~ 28N · m

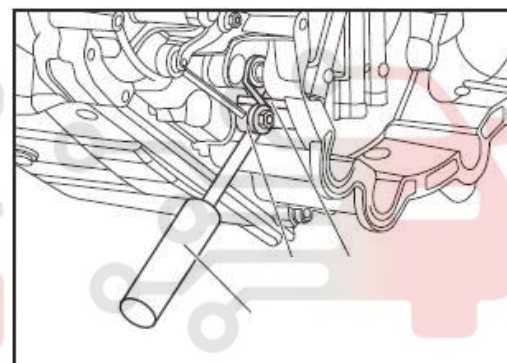
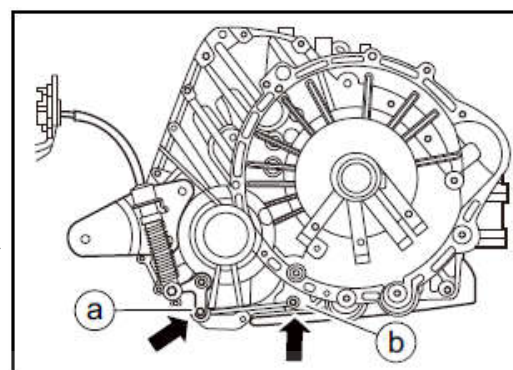

## ( IV ) Adjust

## 1. Adjust gear shift lever

- 1). Shift the gear lever on P.
- 2). Ensure the gearbox is on P.
- 3). If gear shift lever is not on P position, push to the correct position by hand.

△Note: P gear can be confirmed by dashboard gear display.

4). At the same time rotate the front wheels of the car until the wheels are locked. Now gearbox is fixed on P position, and you can also switch out the shift lever from P gear, but don't do so. If there is wire bracket, you should firstly connect the wire to bracket.

- 5). connect the wire to the shift lever by bolts and nuts.

- 6). Tighten the nuts.

△Note: Do not bend the wire or shift lever!

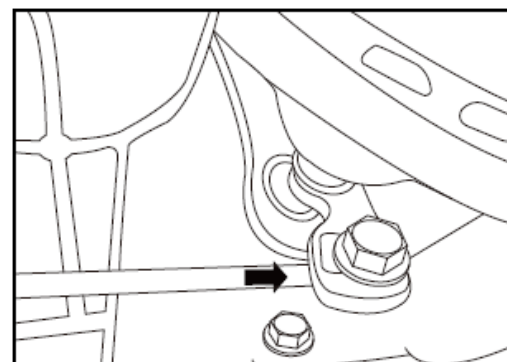
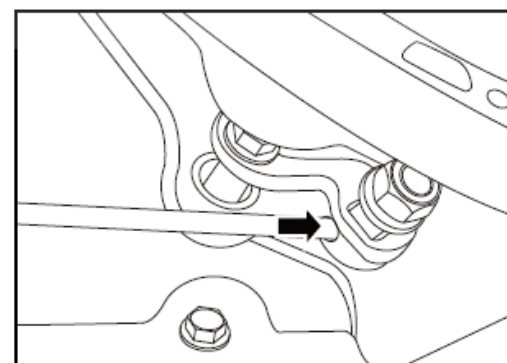

## ( V ) Check

## 1. Check the installation

- 1). Switch the gear shift lever rapidly from P / R / N / D / S / M + / M- for three cycles, check whether the transmission shift lever position is consistent gear display on dash board.
- 2). Switch the gear shift lever slowly from P / R / N / D / S / M + / M- for three cycles, check whether the transmission shift lever position is consistent gear display on dash board.
- 3). If instrument and gear shift lever position is inconsistent or instrument does not show the gear, you must re-adjust the gear.

## VII Gear shift rocker and bushing

## ( I ) Special tools

1	CVT-HDFJ-1	N gear assembly aid tool	
---	------------	--------------------------	---

## ( II ) Remove

1. Remove shift lever assembly, refer to gear shift lever assembly.
2. Remove gear shift rocker and bushing.
  - 1). Removed the worm at the C position (by use screwdriver or opening wrench).
  - 2). Remove bolts at e position.
  - 3). Remove gear shift rocker and bushing.

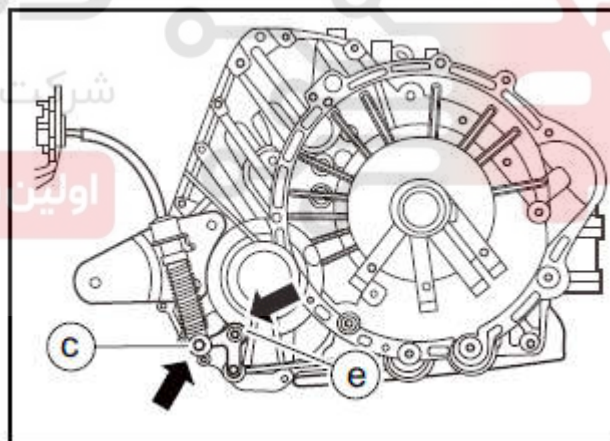

## ( III ) Assemble

## 1. Assemble gear shift rocker and bushing

- 1). Replace the new gear shift rocker and bushing.

△Note: The rocker arrow direction should align to the transmission, at the same time the bush flange closely to the transmission mounting surface.

- 2). Install bolts at e-position, and tighten.

Tighten torque 20~28N·m

## 2. Assemble shift lever assembly

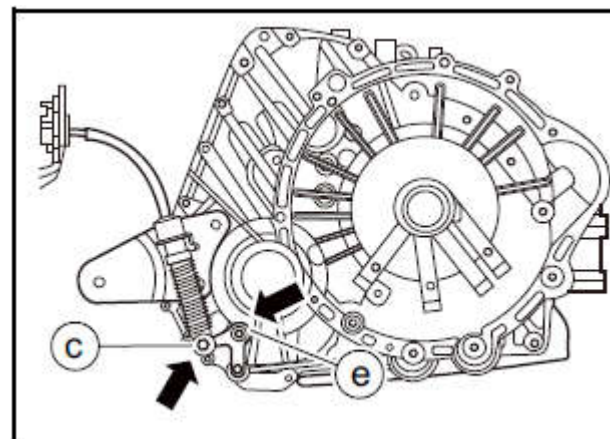

## ( IV ) Check

## 1. Check the installation

- 1). Switch the gear shift lever rapidly from P / R / N / D / S / M + / M- for three cycles, check whether the transmission shift lever position is consistent gear display on dash board.
- 2). Switch the gear shift lever slowly from P / R / N / D / S / M + / M- for three cycles, check whether the transmission shift lever

position is consistent gear display on dash board.

3). If instrument and gear shift lever position is inconsistent or instrument does not show the gear, you must re-adjust the gear.

## VIII The gear shift wiredrawing assembly

### ( I ) Special tools

1	CVT-HDFJ-1	N gear assembly aid tool	
---	------------	--------------------------	---

### ( II ) Remove

1. Remove shift lever assembly, refer to gear shift lever assembly.

2. Remove gear shift rocker and bushing, refer to gear shift rocker and bushing.

3. Remove gear shift wiredrawing assembly.

1). Disconnect the gear shift wiredrawing quick coupling from the bracket at D position. disconnect the gear shift wiredrawing from gearbox assembly.

△Note: must ensure the brackets are all located in connector slot.

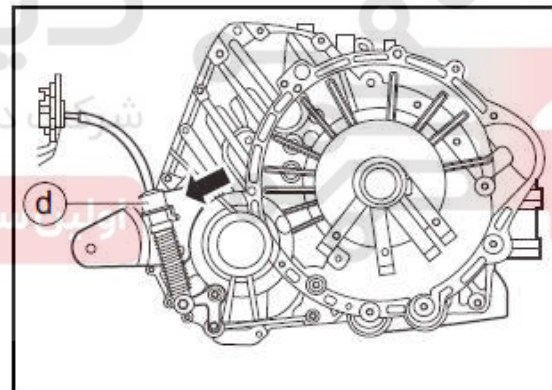

2). Shift to N position, remove the connector of wiredrawing and the transmission operating mechanism.

3). Remove the spring snap.

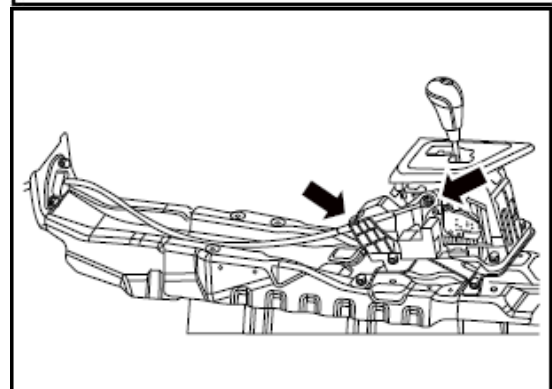

4). Remove the 2 M8 bolts on body front wall.

5). Remove gear shift wiredrawing assembly.

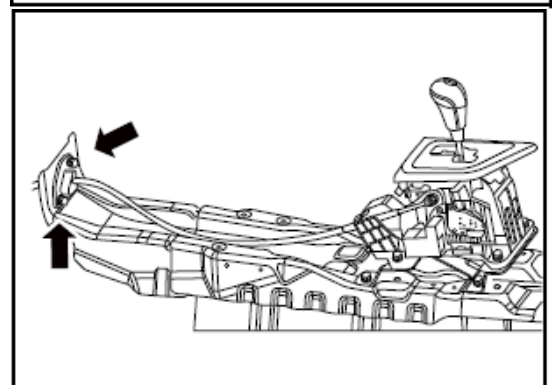

## CVT Transmission

## (III) Assemble

## 1. Install gear shift wiredrawing assembly

- 1). Pass the new gear shift wiredrawing through the engine compartment " body front wall through-hole " to cockpit.
  - 2). Tighten the 2 M8 bolts on body front wall.  
Tighten torque 20~28N·m
  - 3). Connected the "wiredrawing connectors (gear shift mechanism end)" to the gear shift mechanism pin.
  - 4). Install the "spring snap" to right place.
2. Assemble gear shift rocker and bushing.
  3. Assemble shift lever assembly.

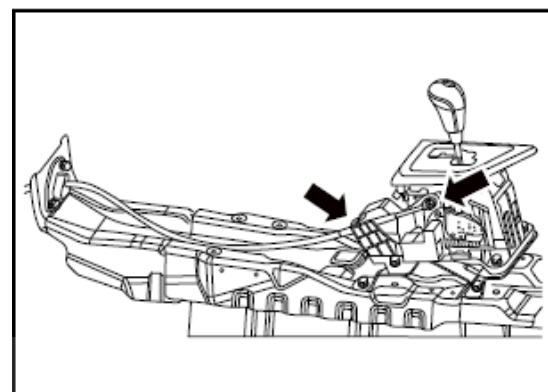
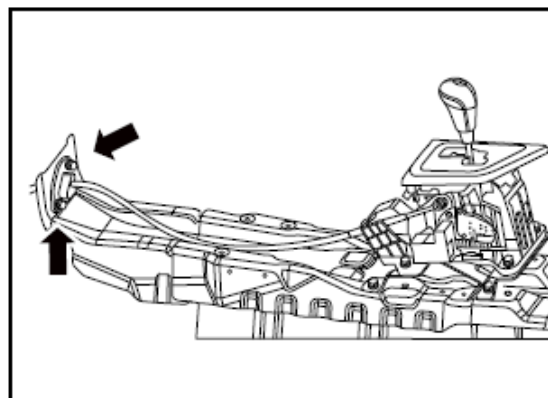

## (IV) Check

## 1. Check the installation

- 1). Switch the gear shift lever rapidly from P / R / N / D / S / M + / M- for three cycles, check whether the transmission shift lever position is consistent gear display on dash board.
- 2). Switch the gear shift lever slowly from P / R / N / D / S / M + / M- for three cycles, check whether the transmission shift lever position is consistent gear display on dash board.
- 3). If instrument and gear shift lever position is inconsistent or instrument does not show the gear, you must re-adjust the gear.

اولین سامانه دیجیتال تعمیرکاران خودرو در ایران

## IX Gear shift operating mechanism assembly

## ( I ) Special tools (none)

## ( II ) Remove

## 1. Remove gear shift operating mechanism assembly

- 1). Shift to N position, remove the connector of wiredrawing and the transmission operating mechanism.
- 2). Remove the spring snap.
- 3). Remove the 4 bolts, remove gear shift operating mechanism assembly.

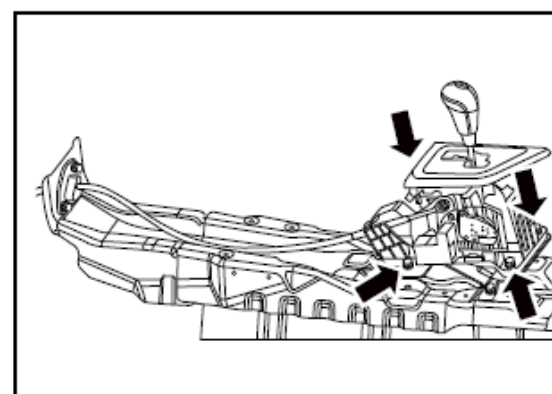
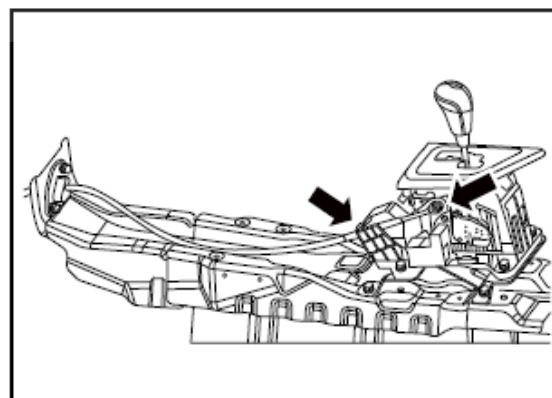

CVT Transmission

(III) Assemble

1. Install gear shift operating mechanism assembly.

- 1). Install gear shift operating mechanism assembly on body.
- 2). Tighten 4 bolts. Tighten torque 20~28N·m
- 3). Connected the "wiredrawing connectors (gear shift mechanism end)"

to the gear shift mechanism pin.

- 4). Install the "spring snap" to right place.

2. Assemble gear shift rocker and bushing.

3. Assemble shift lever assembly.

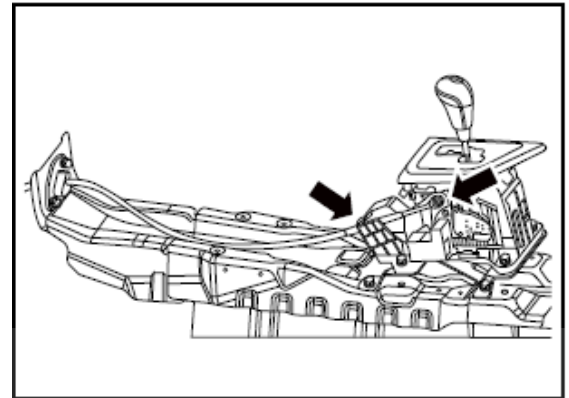
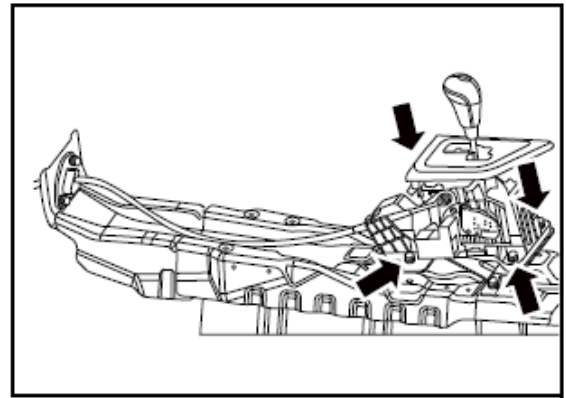

(IV) Check

1. Check the installation

- 1). Switch the gear shift lever rapidly from P / R / N / D / S / M + / M- for three cycles, check whether the transmission shift lever position is consistent gear display on dash board.
- 2). Switch the gear shift lever slowly from P / R / N / D / S / M + / M- for three cycles, check whether the transmission shift lever position is consistent gear display on dash board.
- 3). If instrument and gear shift lever position is inconsistent or instrument does not show the gear, you must re-adjust the gear.

X Differential oil seal

( I ) Special tools

1	16G0038	Differential oil seal installation tool	
---	---------	---	--

( II ) Remove

1. Discharge gearbox oil.
2. Remove Axle refer to the drive shaft.
3. Remove differential oil seal.
  - 1). Pry out the seal with a large flat head screwdriver.

△Note: Be careful don't put the screwdriver too deep to protect the casing.

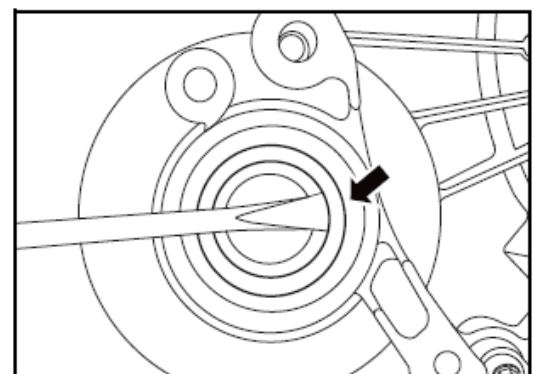

## CVT Transmission

## (III) Assemble

## 1. Install differential oil seal

1). Put the new oil seal on the casing.

2). Put the special tool 16G0038 on seal, knock into the casing with a rubber mallet, make sure it fits.

△Note: The seal depth with casing edge distance is  $3\text{mm} \pm 0.3\text{mm}$ .

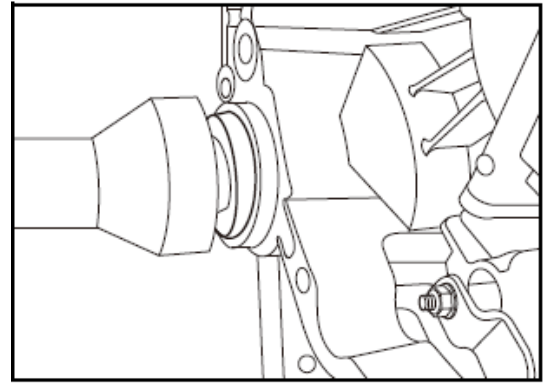

## 2. Install axle

## 3. Fill transmission oil



## XI Input shaft seal

## ( I ) Special tools

No.	Tool No.	Tool name	Tool figure
1	16G0041	Input shaft oil seal install tool	
2	16G0040	Input shaft seal bushing	

## ( II ) Remove

## 1. Discharge gearbox oil.

## 2. Remove transmission assembly, refer to transmission assembly.

## 3. Remove input shaft seal.

1). Pry out the seal with a large flat head screwdriver.

△Note: pry out from void side, must be careful. Or may damage transmission input shaft.

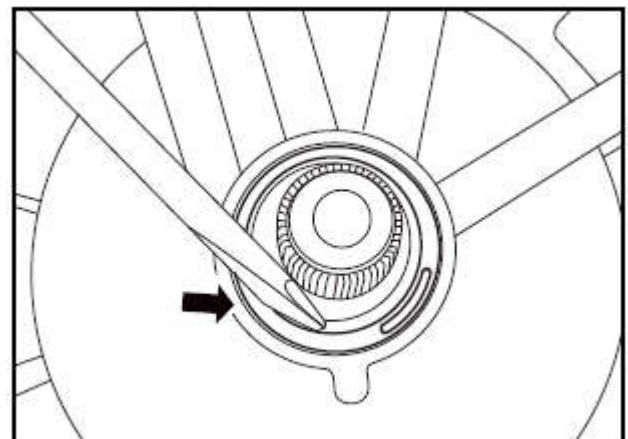

CVT Transmission

(III) Assemble

1. Install input shaft oil seal

1). Put the seal bushing 16G0040 on the input shaft.

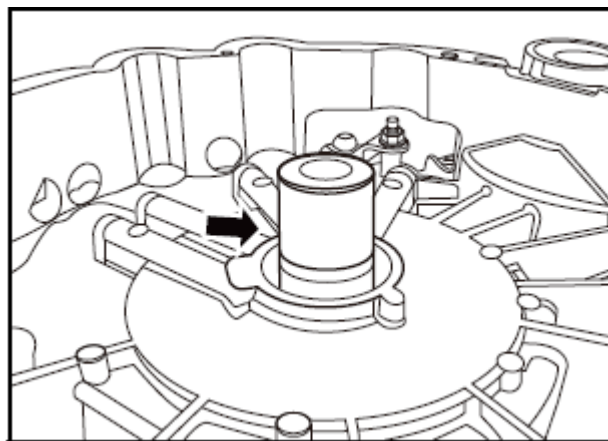

2). Put the new oil seal on the bushing.

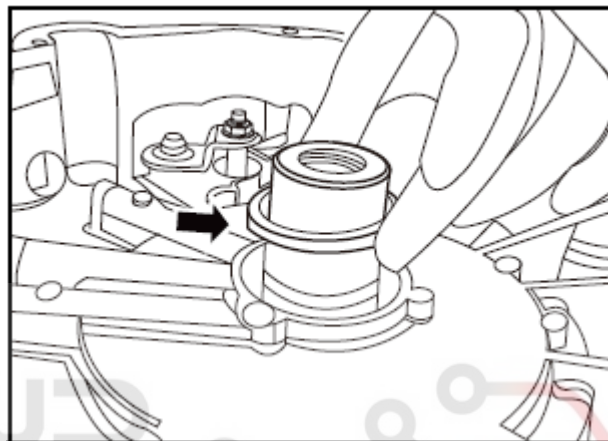

3). Put the special tool 16G0041 on input shaft, knock into the special tool with a rubber mallet, make sure it fits.

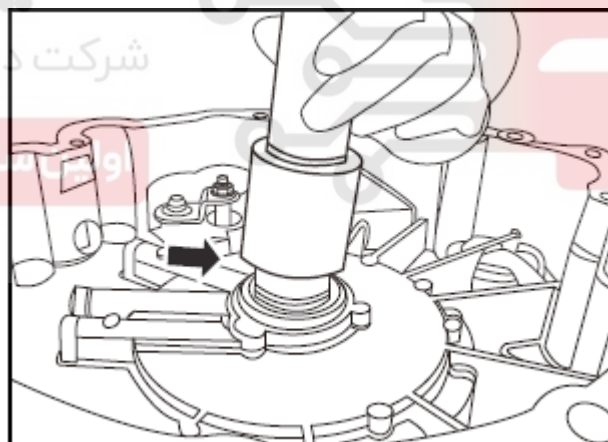

2. Assemble transmission.

3. Fill transmission oil.

XII Selection gear shaft seal

( I ) Special tools

No.	Tool No.	Tool name	Tool figure
1	16G0043	Selection gear shaft seal installation tool	



## CVT Transmission

2	16G0042	Selection gear shaft seal remove tool	
---	---------	---------------------------------------	---

## ( II ) Remove

1. Discharge gearbox oil
2. Remove transmission
3. Remove gear selection lever
4. Remove selection gear shaft seal

1). Put the special tool 16G0042 on selection gear shaft, rotate the special tool into seal with a wrench.

△Note: press the wrench top end which makes special tools screwed into seal.

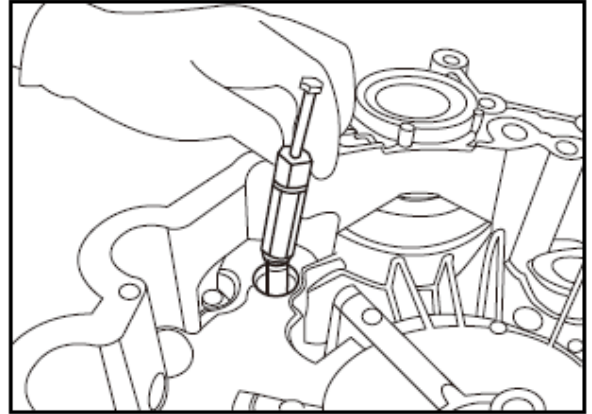

2). Rotate the bolt on special tool with other tool, pull the selection gear shaft seal out from the casing.

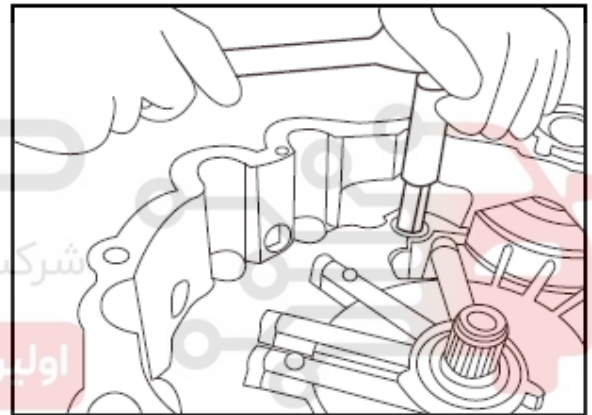

3). Rotate the small bolt, pull out seal.

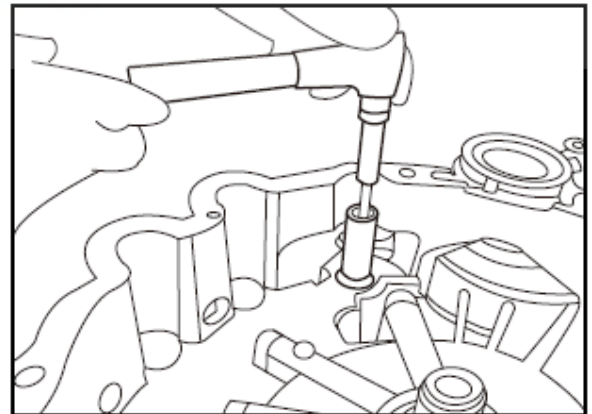

4). Remove seal.

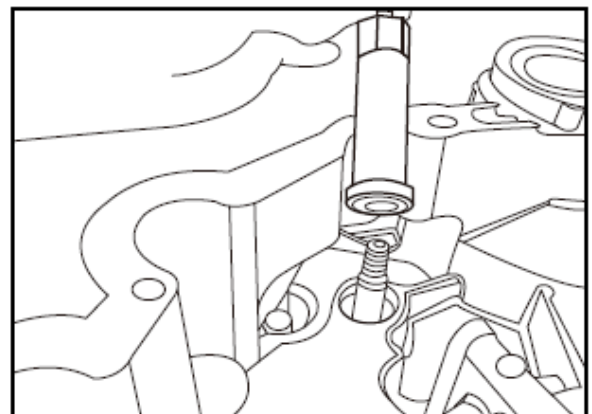

(III) Assemble

1. Install the selection gear shaft seal.
  - 1). Apply vaseline or grease at the tip of the seal punch 16G0043.
  - 2). Put the new seal on the punch 16G0043 slightly.

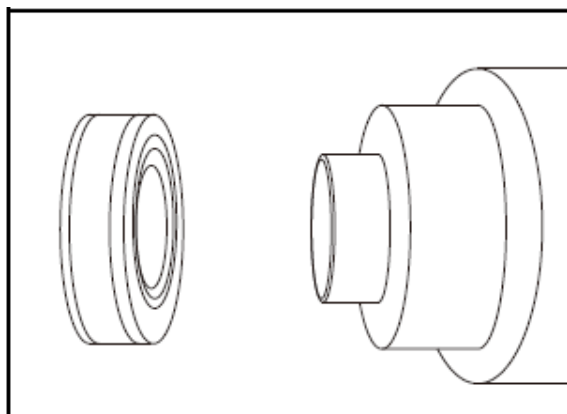

- 3). Put the installed special punch 16G0043 on selection gear shaft, and tapping with a hammer to fit.

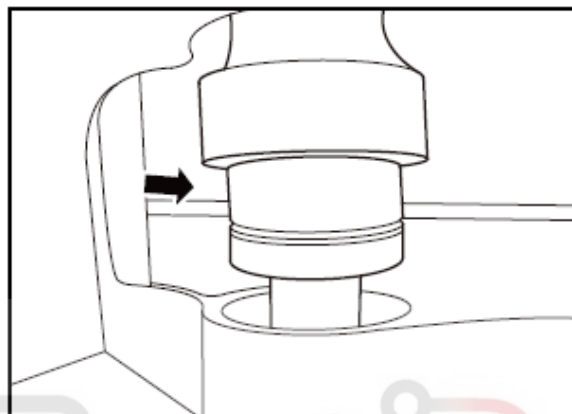

- 4). Remove punch 16G0043.

△Note: rotate out the punch, or it would pull out seal and punch together.

2. Install gear shift lever
3. Assemble transmission
4. Fill transmission oil

XIII Driving bevel gear cover

( I ) Special tools (none)

( II ) Remove

1. Discharge gearbox oil
2. Remove driving bevel gear cover
  - 1). Remove 3 bolts, take down snaps.
  - 2). Pry the cover down with screwdriver, take out O ring and cover.

△Note: place some clothes below the transmission to prevent damage the casing.

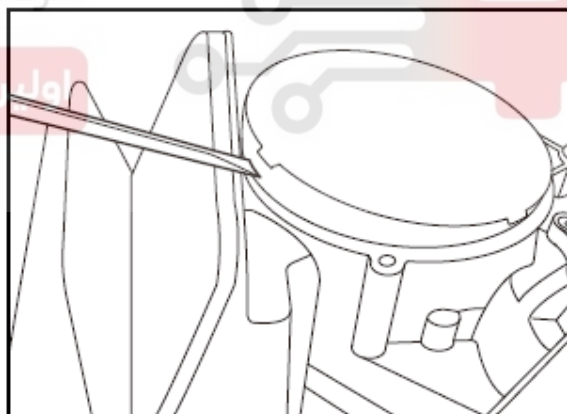

(III) Installation

1. Install driving bevel gear cover
  - 1). Install new O ring, and assemble new cover and tighten the bolts and snaps. Tighten torque  $9.5 \pm 2.5N \cdot m$ .
  - 2). Fill transmission oil.

XIV Pump

( I ) Special tools

No.	Tool No.	Tool name	Tool figure

## CVT Transmission

1	16G0045	Pump removal tools	
---	---------	--------------------	---

## ( II ) Remove

1. Discharge gearbox oil
2. Remove transmission
3. Remove driving bevel gear shaft cover, refer to driving bevel gear cover.
4. Remove pump
  - 1). Remove the 6 bolts on the pump, put the special tool on pump shaft.

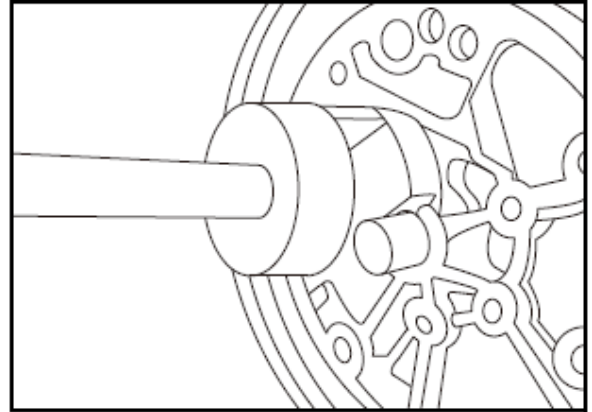

- 2). Pull out pump with 16G0045 special tool.

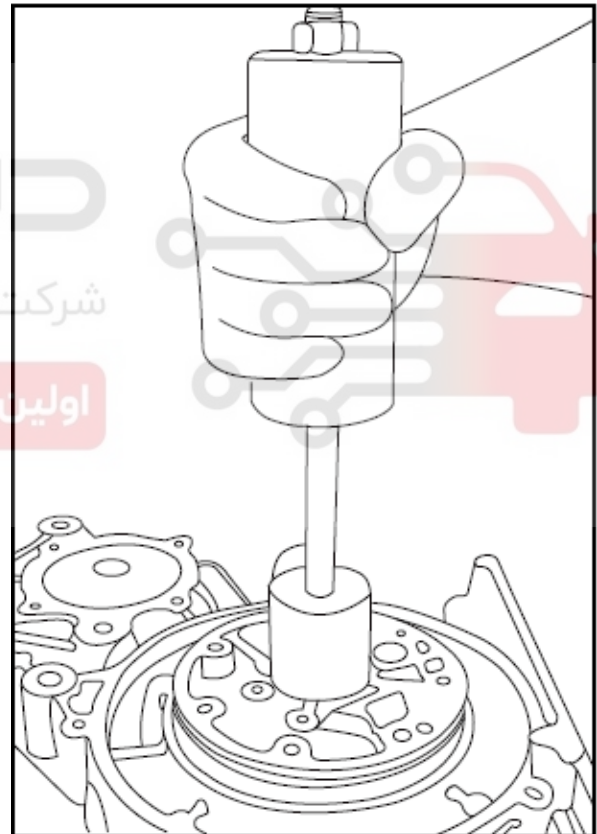

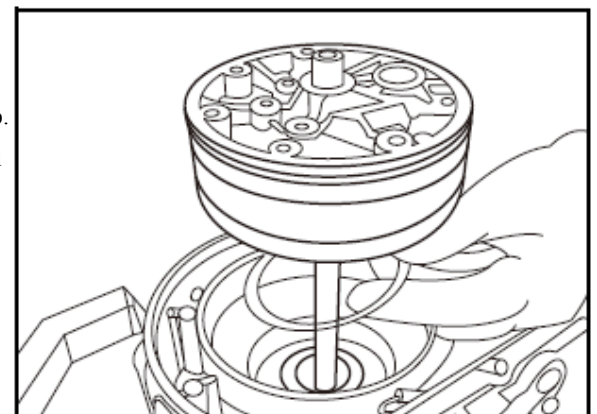

## ( III ) Assemble

1. Install pump
  - 1). Install new pump, must make sure put 2 new O ring on the new pump.  
△Note: don't take out bevel return spring, and confirm the larger diameter end towards the pump.
  - 2). Re-install 6 bolts and tighten. Tighten torque  $10 \pm 1 \text{ N} \cdot \text{m}$ .
2. Install driving bevel gear shaft cover.  
△Note: don't need to replace O ring and cover.
3. Assemble transmission.
4. Fill transmission oil.

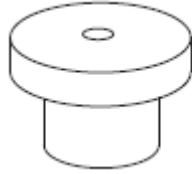

## XV Driving bevel gear shaft ball bearing

## ( I ) Special tools

No.	Tool No.	Tool name	Tool figure
1	16G0049	Driving bevel gear bearing stopper	
2	16G0050	Driving bevel gear bearing punch	
3	16G0048	Driving bevel gear bearing remove tool	

## ( II ) Remove

1. Discharge gearbox oil.
2. Remove transmission.
3. Remove driving bevel gear shaft cover, refer to driving bevel gear cover.
4. Remove pump, refer to pump.
5. Remove the driving bevel gear bearing.
  - 1). Take out bevel return spring.
  - 2). Take marks on shaft and nuts.
  - 3). Remove nuts with special tool.
  - 4). Take down dust cover from shaft with screwdriver.

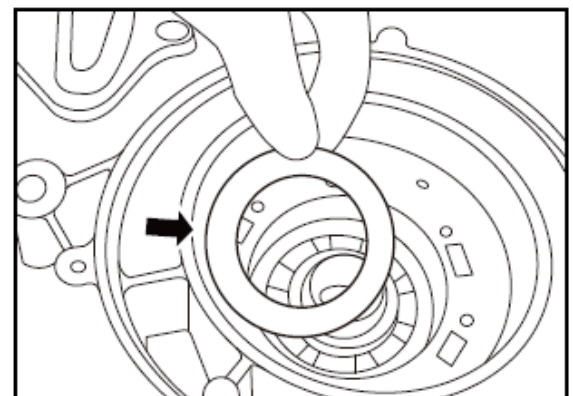
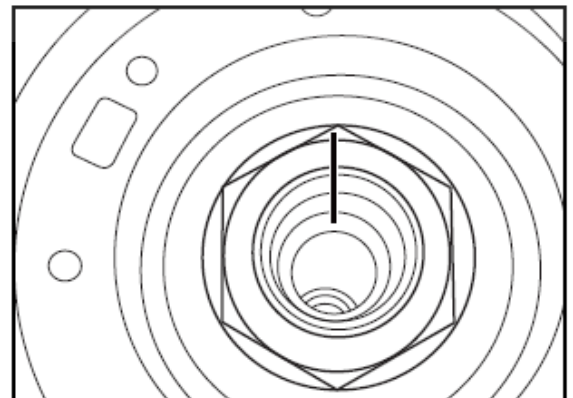

## CVT Transmission

5). Put the protect plug on the shaft.

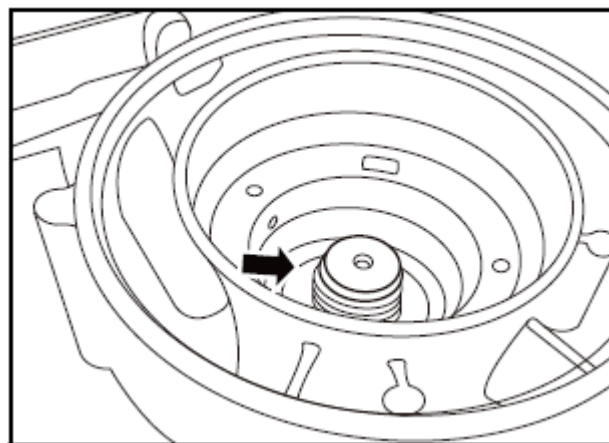

6). Assemble bearing ejector (16G0048) , hook the out ring of the bearing with it's foots.

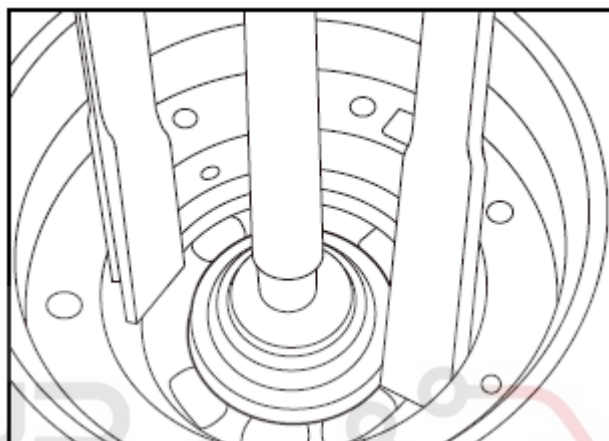

7). Tighten the Middle bolt, in order to pull out bearing.

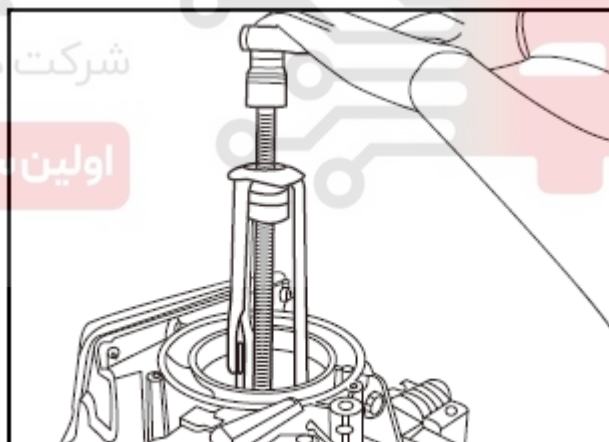

### (III) Assemble

1. Install driving bevel gear shaft ball bearing.

1). Clean the sealant on the the driving bevel gear shaft and pump driving shaft lock belt, clean the oil pump chamber.

2). Put the new bearing on the right place, and install with special punch (16G0050) .

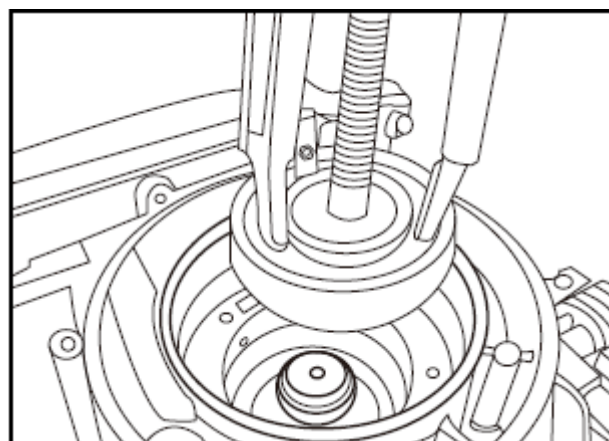

## CVT Transmission

- 3). Tap the punch to right place with rubber hammer.
- 4). Tighten the nut to make the mark on the axis coincides with the mark on the nut.  
Standard coincidence degree  $\pm 5^\circ$ .
- 5). install the bevel return spring.

△Note: the larger diameter end towards the pump.

2. Install pump
3. Install driving bevel gear shaft cover
- △Note: don't need to replace O ring and cover.
4. Assemble transmission
5. Fill transmission oil

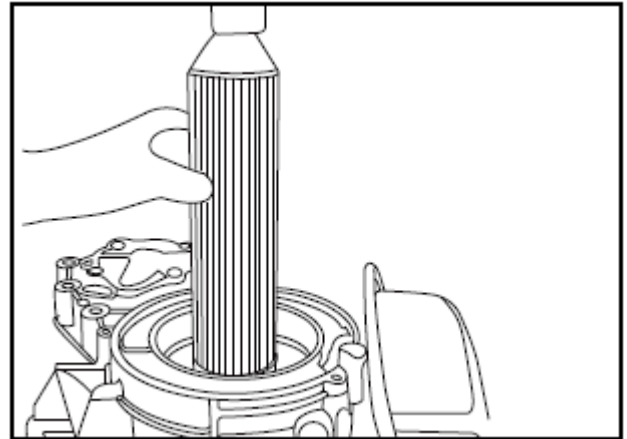

## XVI Driven bevel gear shaft cover

( I ) Special tools (none)

( II ) Remove

1. Remove driven bevel gear shaft cover
  - 1). Remove four countersunk screws.
  - 2). Take down the two O rings and a seal ring on the cover.

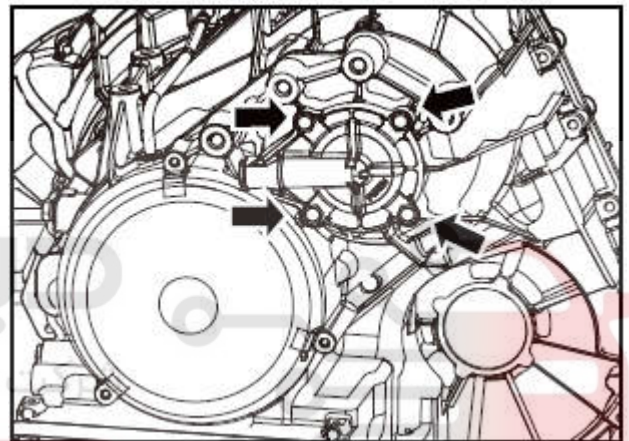

( III ) Assemble

1. Install driven bevel gear shaft cover
  - 1). Re-install the two O rings and a seal ring on the cover.
  - 2). Clean the sealant in the casing's four screw holes.
  - 3). Tighten four screws. Tighten torque  $9.5 \pm 0.95 \text{ N} \cdot \text{m}$ .

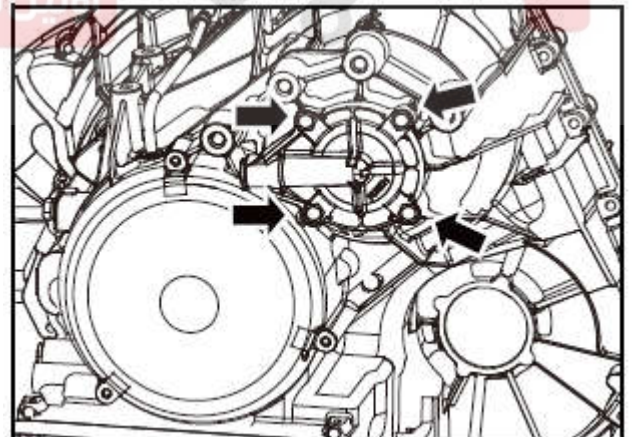

## XVII Oil sump

( I ) Special tools (none)

( II ) Remove

1. Discharge gearbox oil
2. Remove oil sump
  - 1). Remove the 13 bolts on the oil sump.

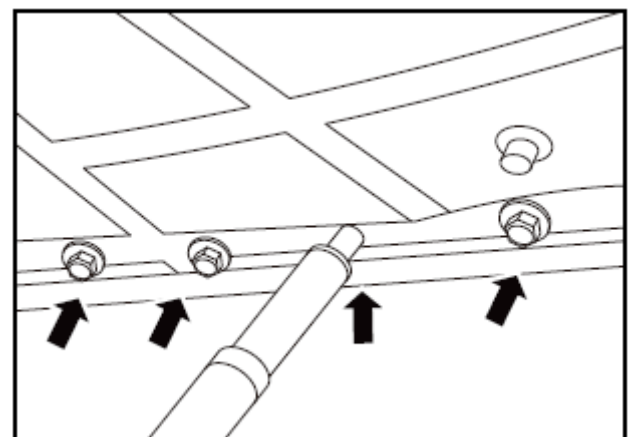

## CVT Transmission

## (III) Assemble

## 1. Install the oil sump

- 1). Install new oil sump and gasket.
- 2). Install the oil sump bolts as the figure shown.

△Note: use the new bolt gasket. Tighten torque  $9.5 \pm 1 \text{ N} \cdot \text{m}$ .

## 2. Fill transmission oil

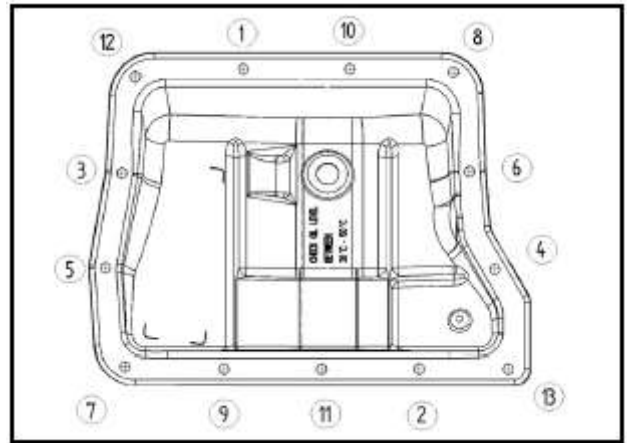

## XVIII Oil filter

## ( I ) Special tools (none)

## ( II ) Remove

1. Discharge gearbox oil
2. Remove oil sump, refer to oil sump.
3. Remove oil filter.
  - 1). Gently remove the oil filter and abolished.

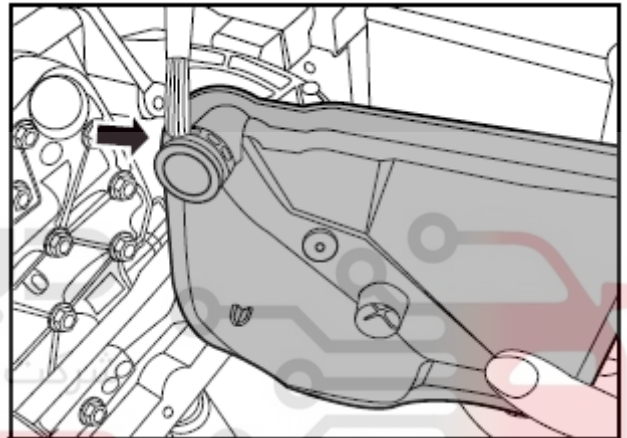

## (III) Assemble

## 1. Install oil filter

- 1). Install a new oil filter with O ring, lubricate with ESSOEZL799(A)
- 2). Gently push the filter in place.

△Note: the oil filters middle hole is justly coincide with the hydraulic control block middle bolt.

- 3). clean the magnet and oil sump.
2. Install the oil sump
3. Fill transmission oil

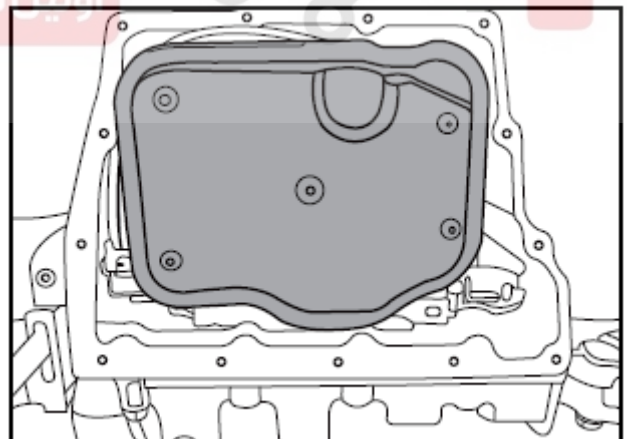

## XIX Driving mode sensor

## ( I ) Special tools (none)

## ( II ) Remove

1. Discharge gearbox oil.
2. Remove oil sump, refer to oil sump.
3. Remove oil filter, refer to oil sump.
4. Remove driving mode sensor.
  - 1). Remove the two screws on the driving mode sensor.

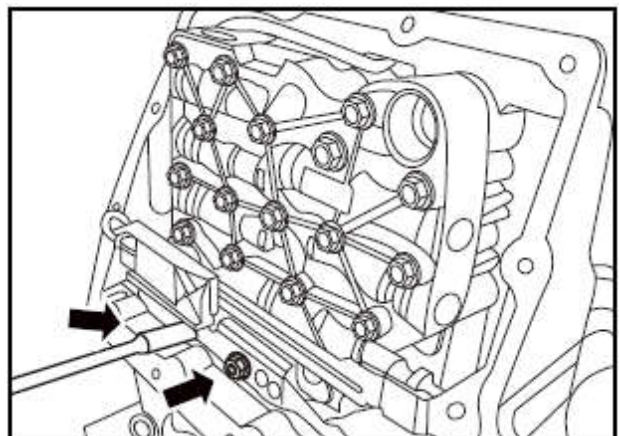

CVT Transmission

2). Carefully remove the driving mode sensor from the hydraulic control block.

△Note: the sensors is fixed on the hydraulic control block metal slide by a small pin behind the sensor, and push down the sensor , the pins woud depart from the metal slide.

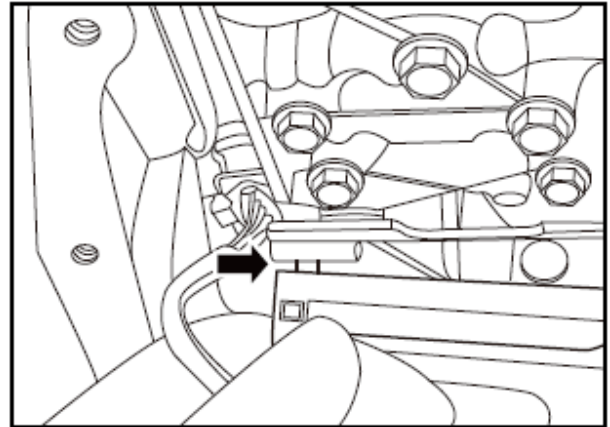

3). Pry out the sensor connectors locker by screwdriver, and press the white buckle to separate the connectors.

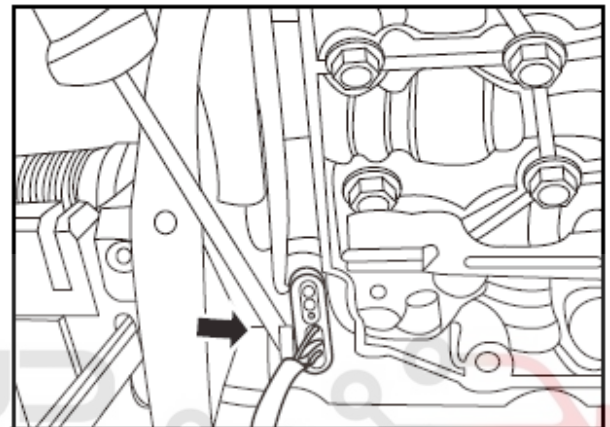

(III) Assemble

1. Install driving mode sensor

1). Take a new sensor, connect the connector and press the white buckle to lock.

2). Put the pin behind the sensor on the metal slide, and install to right place.

3). Move the sensor to expose the bolt hole.

4). Tighten two screws.

Tighten torque  $9.5 \pm 0.95 \text{ N} \cdot \text{m}$

2. Install oil filter

3. Install the oil sump

4. Fill transmission oil

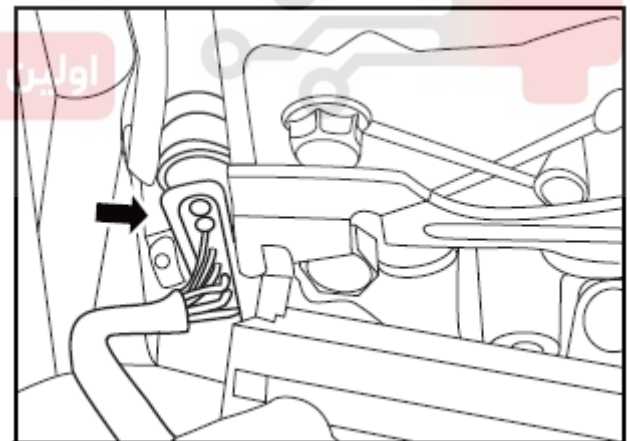

XX Hydraulic control mode

( I ) Special tools

No.	Tool No.	Tool name	Tool figure
1	16G0046	Hydraulic control block locating pin	



## CVT Transmission

## ( II ) Remove

1. Discharge gearbox oil.
2. Remove oil sump, refer to oil sump.
3. Remove oil filter, refer to oil sump.
4. Remove driving mode sensor, refer to driving mode sensor.
5. Remove hydraulic control mode
  - 1). Remove the bolts as the figure shown, from 20 to 1.

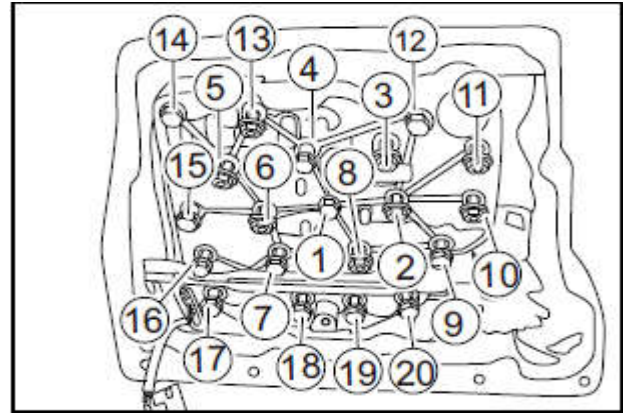

- 2). Take out the hydraulic control mode, and separate the 4 connectors.

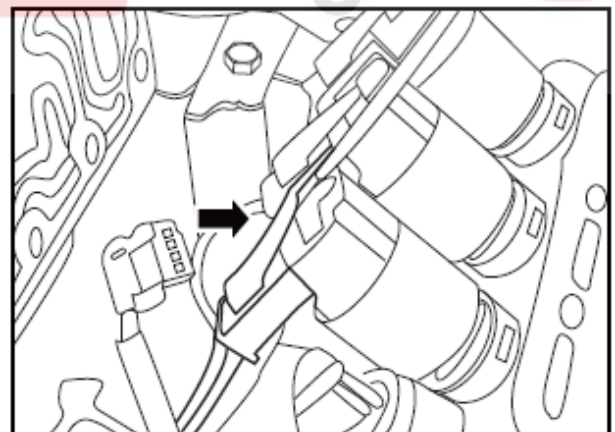
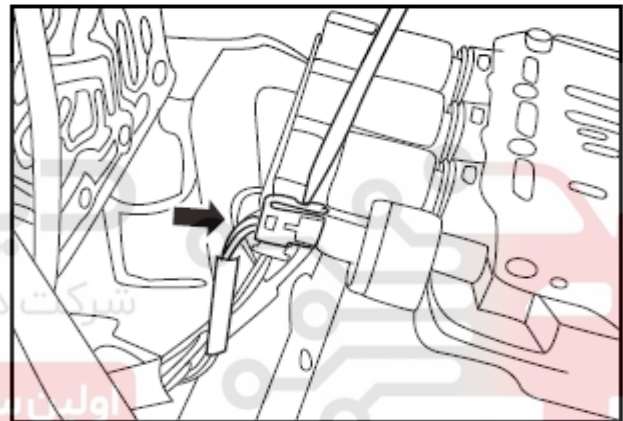

△Note: it's easy to take down the connector with small screwdriver.

## ( III ) Assemble

1. Install hydraulic control block
  - 1). Install the hydraulic control block to right place, there is a small pin behind the hydraulic control block, place to right place.

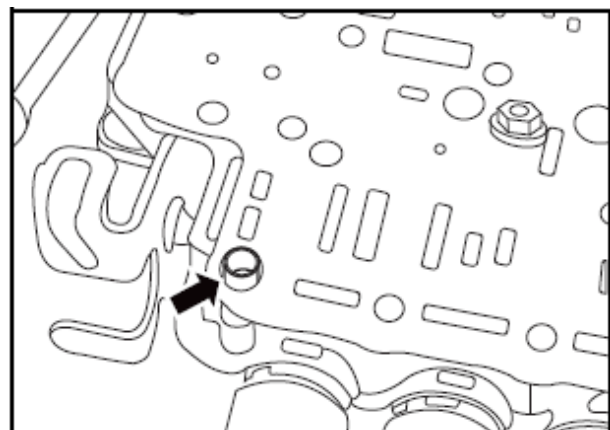

CVT Transmission

- 2). Make sure the metal slide fits with pin on the gear shift cam.
- 3). Install the Middle bolt, and tighten by hand.

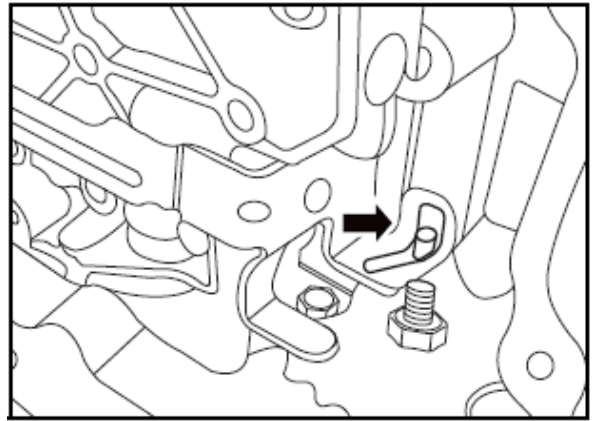

- 4). Place the special tool 16G0046 into bolt hole on the upper left corner.
- 5). Press the driving bevel gear speed sensor wire under the hydraulic control block upper left corner.

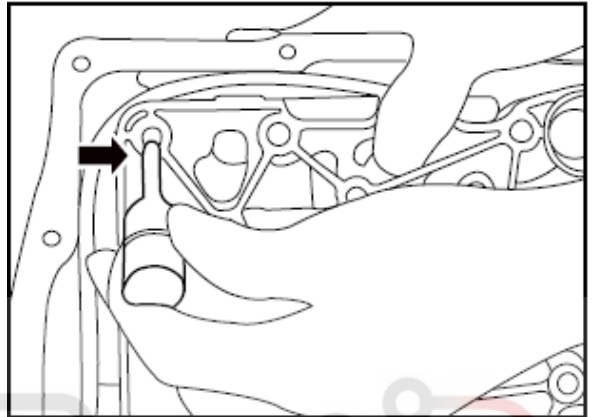

- 6). Assemble all the bolts of the hydraulic control block, tighten (sequence is from 1 to 20).  
Tighten torque 11N·m

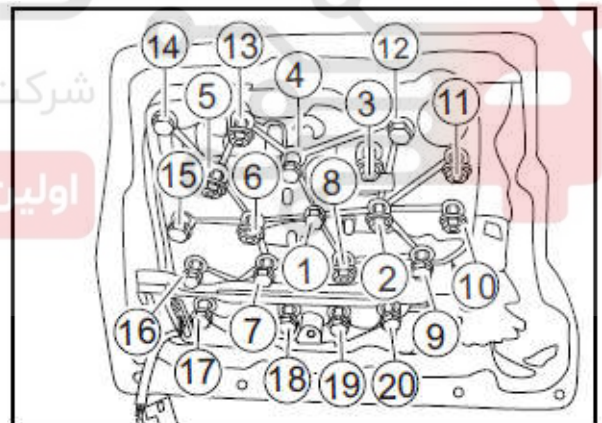

2. Install driving mode sensor
3. Install oil filter
4. Install the oil sump
5. Fill transmission oil

XXI Driven bevel gear speed sensor and bracket

( I ) Special tools (none)

( II ) Remove

1. Discharge gearbox oil.
2. Remove oil sump, refer to oil sump.
3. Remove oil filter, refer to oil sump.
4. Remove driving mode sensor, refer to driving mode sensor.
5. Remove hydraulic control mode, refer to hydraulic control mode.
6. Remove driven bevel gear speed sensor and bracket.

- 1). Loosen sensor bracket bolts.

△Note: the bolts are disposable.

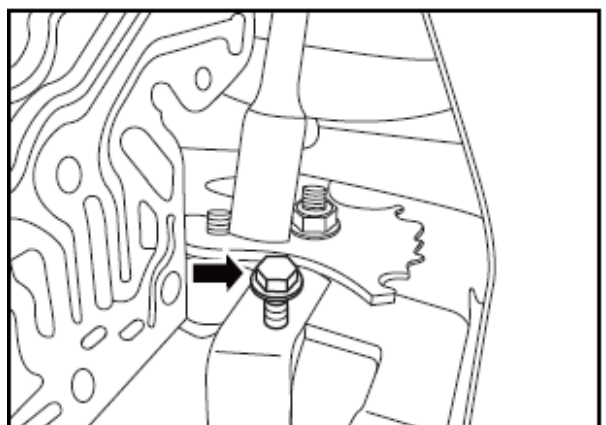

## CVT Transmission

2). Take out the bracket from gear shift shaft.

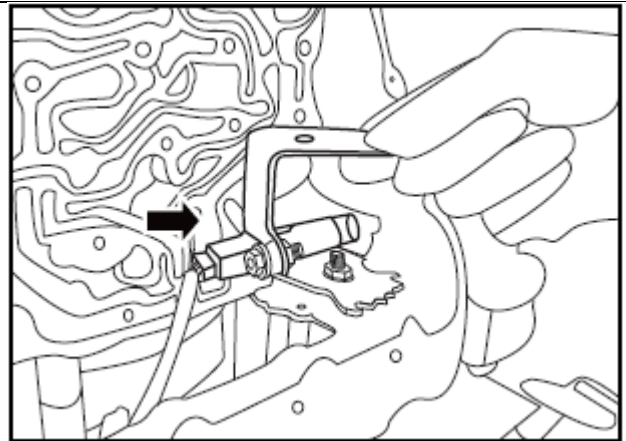

3). Remove the sensor and connector with needle-nose pliers.

4). Loosen the bracket bolts to take down the sensor.

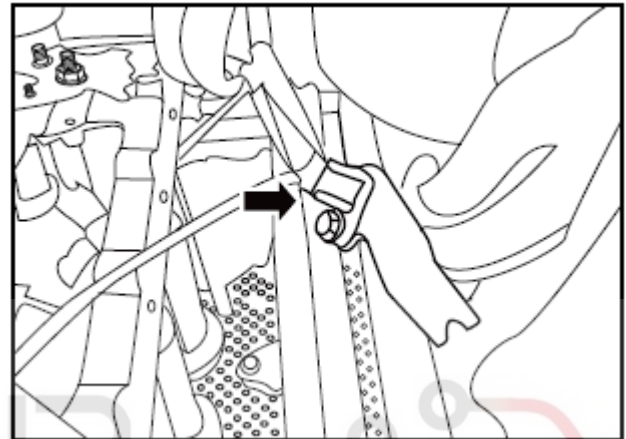

## (III) Assemble

1. Assemble driven bevel gear speed sensor and bracket.

1). Assemble new sensor and bracket, tighten the fixed bolts.

2). Connect the wire and snap the bracket on the gear shift shaft, make sure install to right place.

3). Fixed the bracket with new bolts.

Tighten torque  $9.5 \pm 0.95 \text{N} \cdot \text{m}$

2. Install hydraulic control block

3. Install driving mode sensor

4. Install oil filter

5. Install the oil sump

6. Fill transmission oil

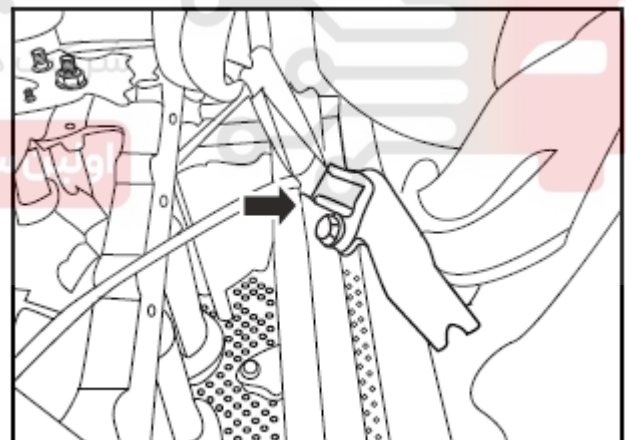

## XXII Driving bevel gear speed sensor

( I ) Special tools (none)

( II ) Remove

1. Discharge gearbox oil

2. Remove driving bevel gear shaft cover, refer to driving bevel gear cover.

3. Remove driving bevel gear speed sensor.

1). Remove the fixed bolts, take out the sensor.

2). Separate the wire and take down the sensor.

### (III) Assemble

1. Assemble driving bevel gear speed sensor.

1). Assemble new sensor, and tighten the bolts.

Tighten torque  $8.5 \pm 2 \text{N} \cdot \text{m}$

2). Connect the wire to sensor.

2. Install driving bevel gear cover.

3. Fill transmission oil.

## XXIII Main connector and inner harness

### ( I ) Special tools (none)

### ( II ) Remove

1. Discharge gearbox oil

2. Remove oil sump, refer to oil sump.

3. Remove oil filter, refer to oil sump.

4. Remove driving mode sensor, refer to driving mode sensor.

5. Remove hydraulic control mode, refer to hydraulic control mode.

6. Remove main connector and inner harness.

1). Separate the two speed sensors' connectors.

2). Remove the wire connected with the main connector.

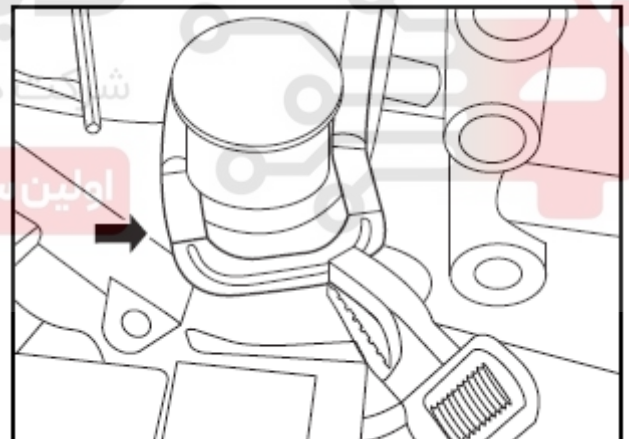

3). Remove the snap on the main connector, and clamp the main connector into the transmission.

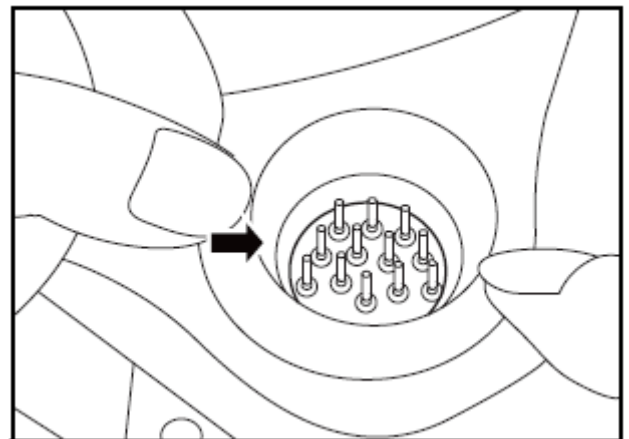

## CVT Transmission

△Note: Driving mode sensor connector is clamped on casing, remove this joint first.

- 4). Take the main connector out from the transmission.

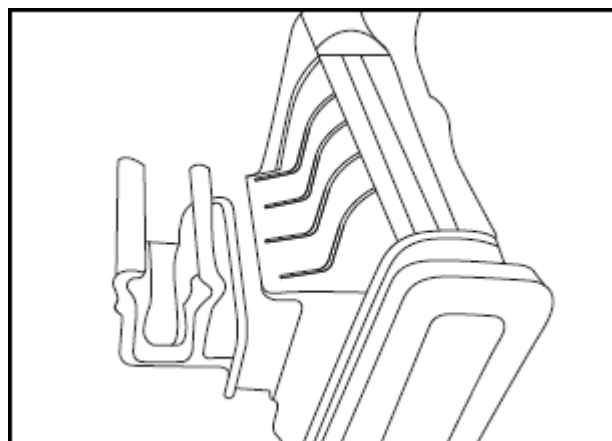

## (III) Assemble

1. Install main connector and inner harness.

- 1). Take a new connector, place into transmission.

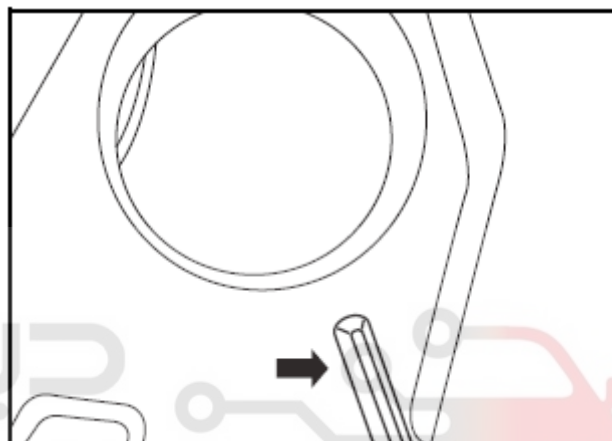

△Note: main connector is connected to casing by a spline, it would be easy to connect by pressing with a needle-nose plier at 45 degree position.

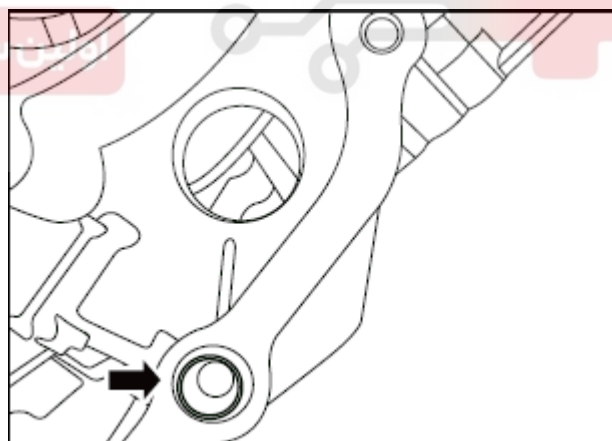

- 2). Re-install the snap.

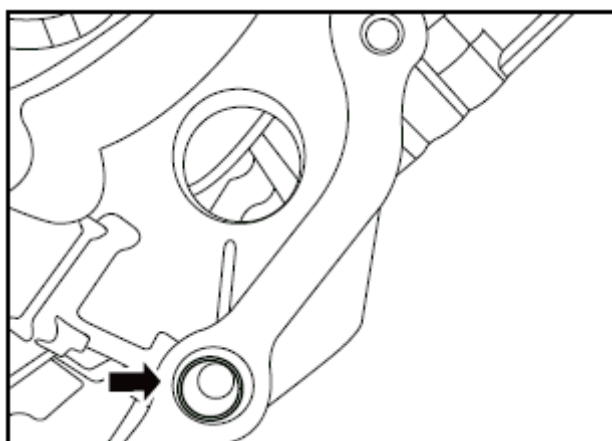

CVT Transmission

- 3). Assemble the driving mode sensor connector on the casing.
  - 4). Connect the speed sensor with connector.
2. Install hydraulic control block
  3. Install driving mode sensor
  4. Install oil filter
  5. Install the oil sump
  6. Fill transmission oil

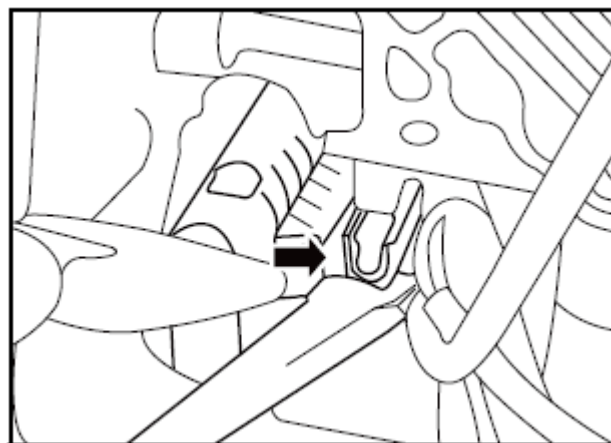

XXIV Ventilator tube

( I ) Special tools

No.	Tool No.	Tool name	Tool figure
1	16G0044	Install ventilator tube	

( II ) Remove

1. Disassemble the engine intake manifold.
2. Disassemble the battery and bracket.
3. Disassemble the ventilator tube.
  - 1). Remove the snaps which connects ventilator tube top and gearbox.
  - 2). Place the plier on the junction of casing and ventilator tube, remove the ventilator tube.

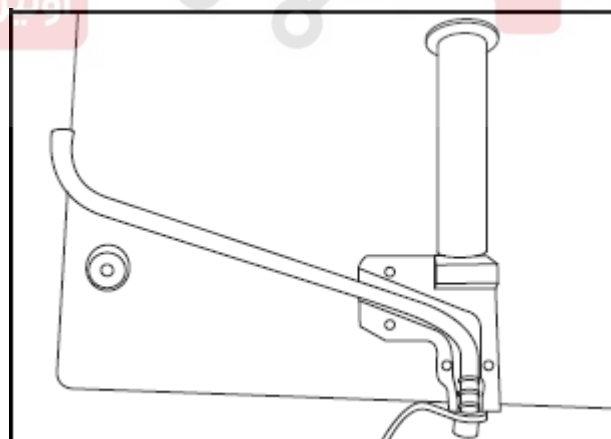

( III ) Assemble

1. Install ventilator tube
  - 1). Place the new ventilator into special tool ( 16G0044 ) , apply a little vaseline on aluminum tube at the bottom of the ventilator tube.
  - 2). Place the tool box ventilator tube on the casing, keep them parallel, tap tools perpendicular down with a rubber hammer to make ventilator tube into the housing.
  - 3). Place the 482253 plastic snap on the breathing tube.

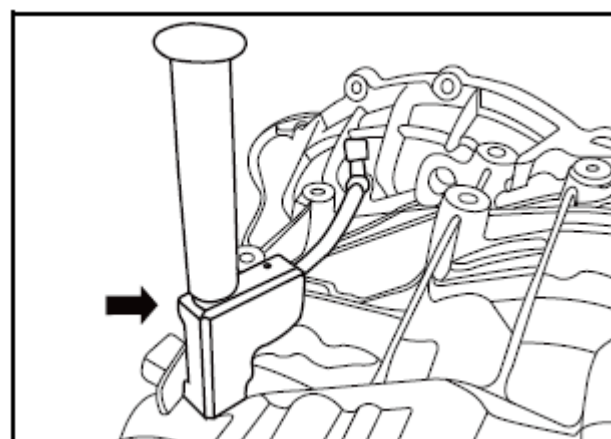

CVT Transmission

- 4). Insert the pin on the plastic snap into 481456 metal snap hole.
  - 5). Securely mount the metal snap on the rib of the transmission casing.
  - 6). Mount the 483117 breathing tube cap on the tube, pay attention to fit.
2. Assemble the battery and bracket.
  3. Assemble the engine intake manifold.

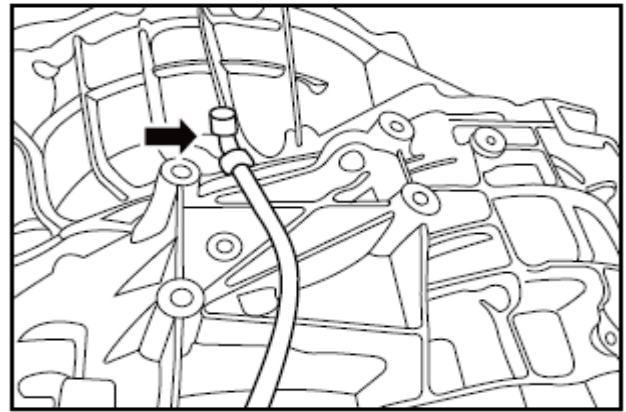

XXV Electrical schematic diagram

( I ) TCU Interface Figure

TCU Interface Figure

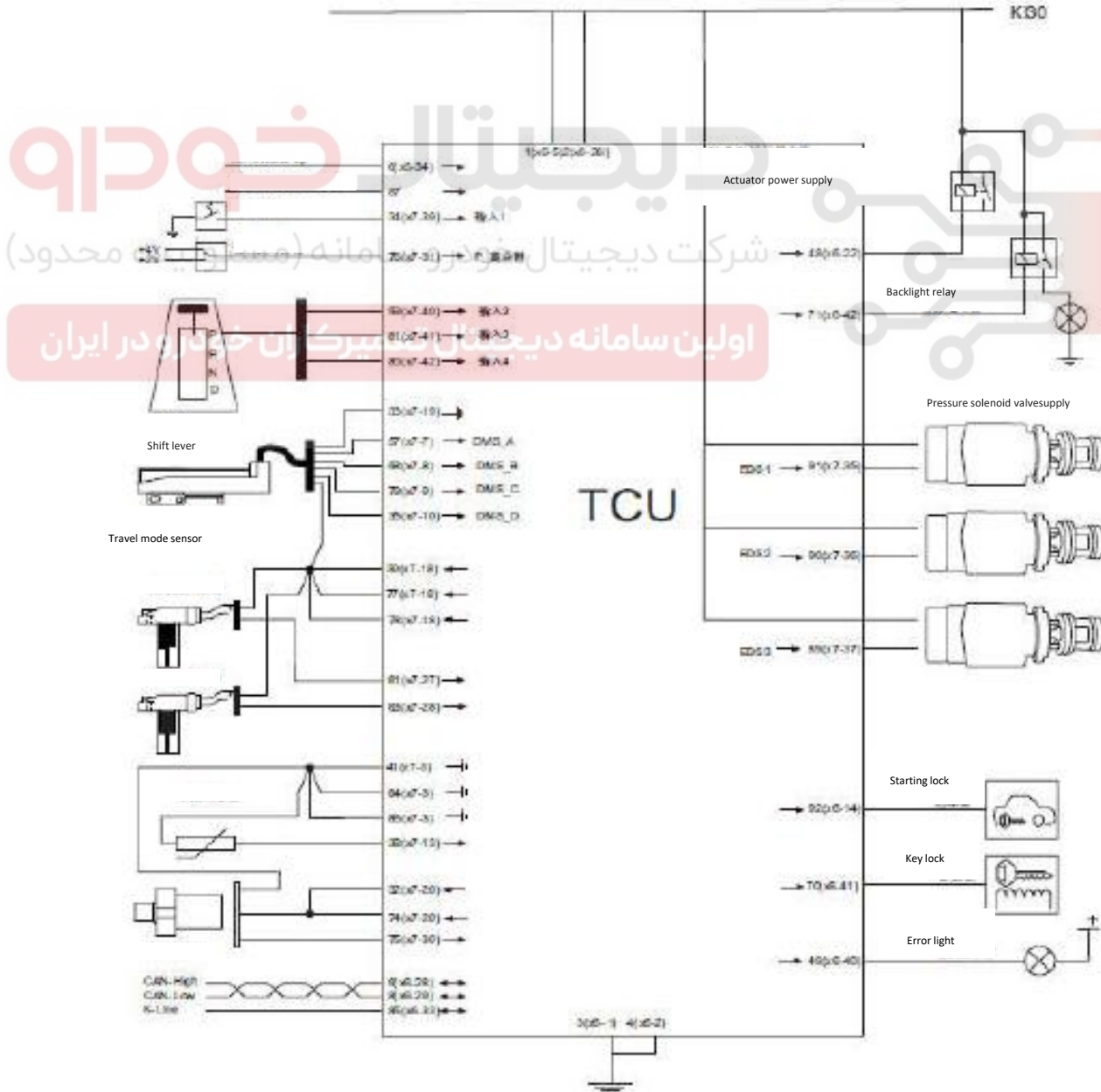

CVT Transmission

The interface of TCU and transmission

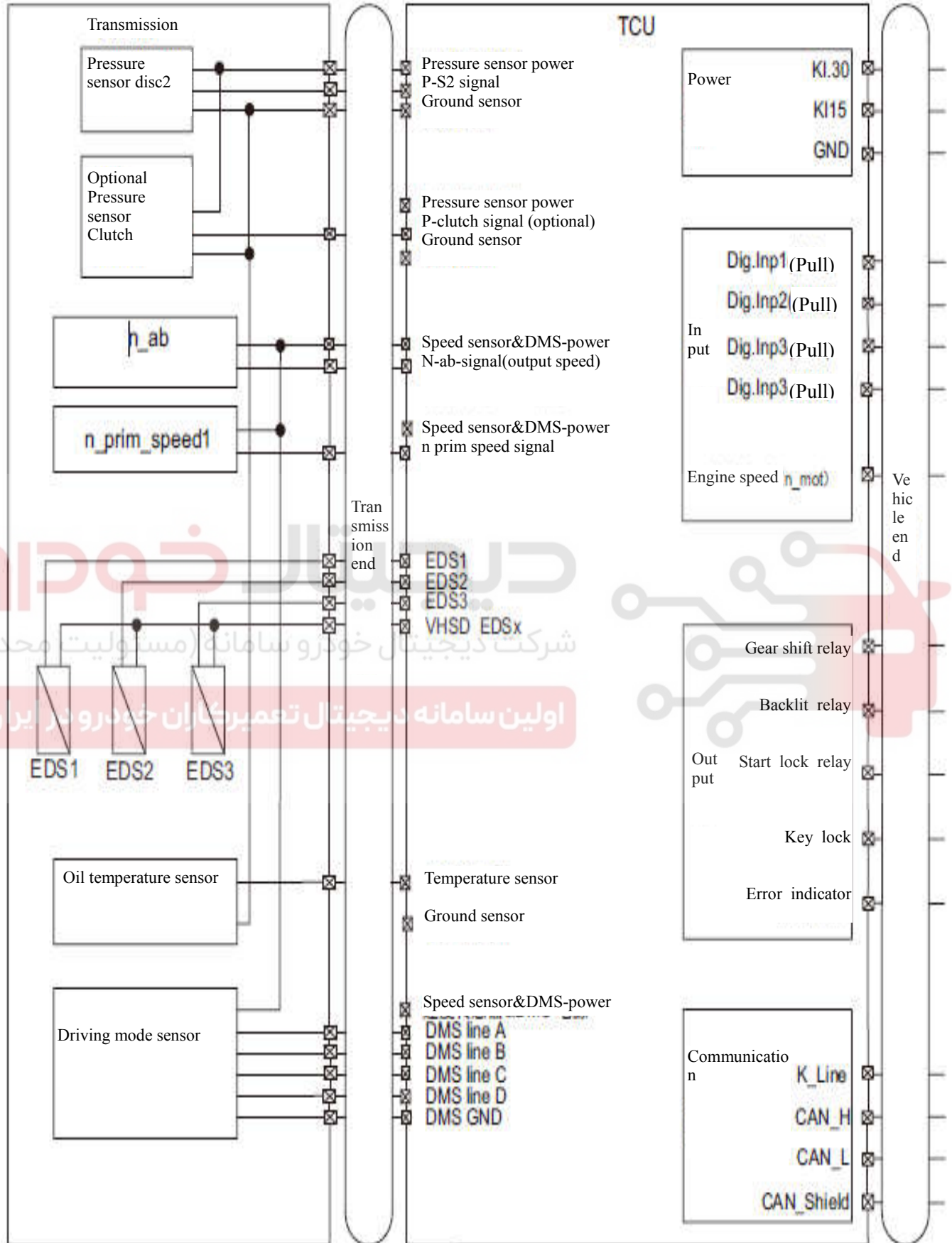



CVT Transmission

Transmission main connector pin

Connector layout  
(transmission side )

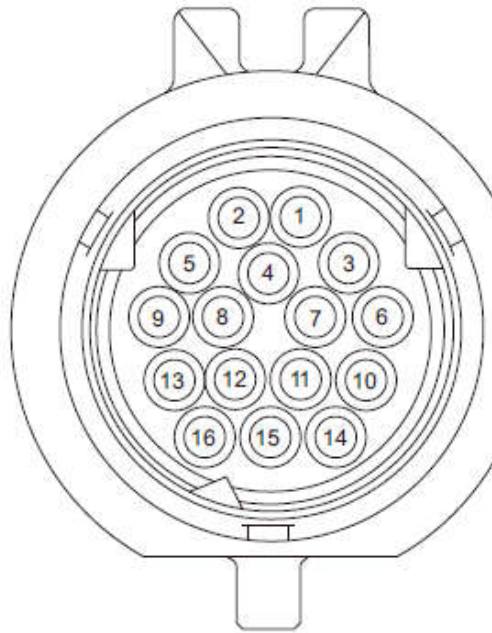

Pin allocation

Pin	Signal	Pin	Signal
1	Supply valve	9	Power- 8.4v
2	EDS_1	10	p_S2
3	EDS_2	11	n_ab
4	EDS_3	12	n_S1
5	Oil temperature	13	DMS_A
6	DMS_GND	14	DMS_B
7	Sensor GND	15	DMS_C
8	Power-5v	16	DMS_D

Signal	Illustrate
DMS	Driving mode sensor or gear / suppression sensor
EDS_1	Driving bevel gear pressure regulator (Solenoid valve)
EDS_2	Driven bevel gear pressure regulator (Solenoid valve)
EDS_3	Cutch pressure regulator (Solenoid valve)
P_S2	Driven bevel gear pressure sensor
N_ab	Driven bevel gear speed sensor
N_S1orN_Prim	Driving bevel gear speed sensor

CVT Transmission

TCU pin schematic

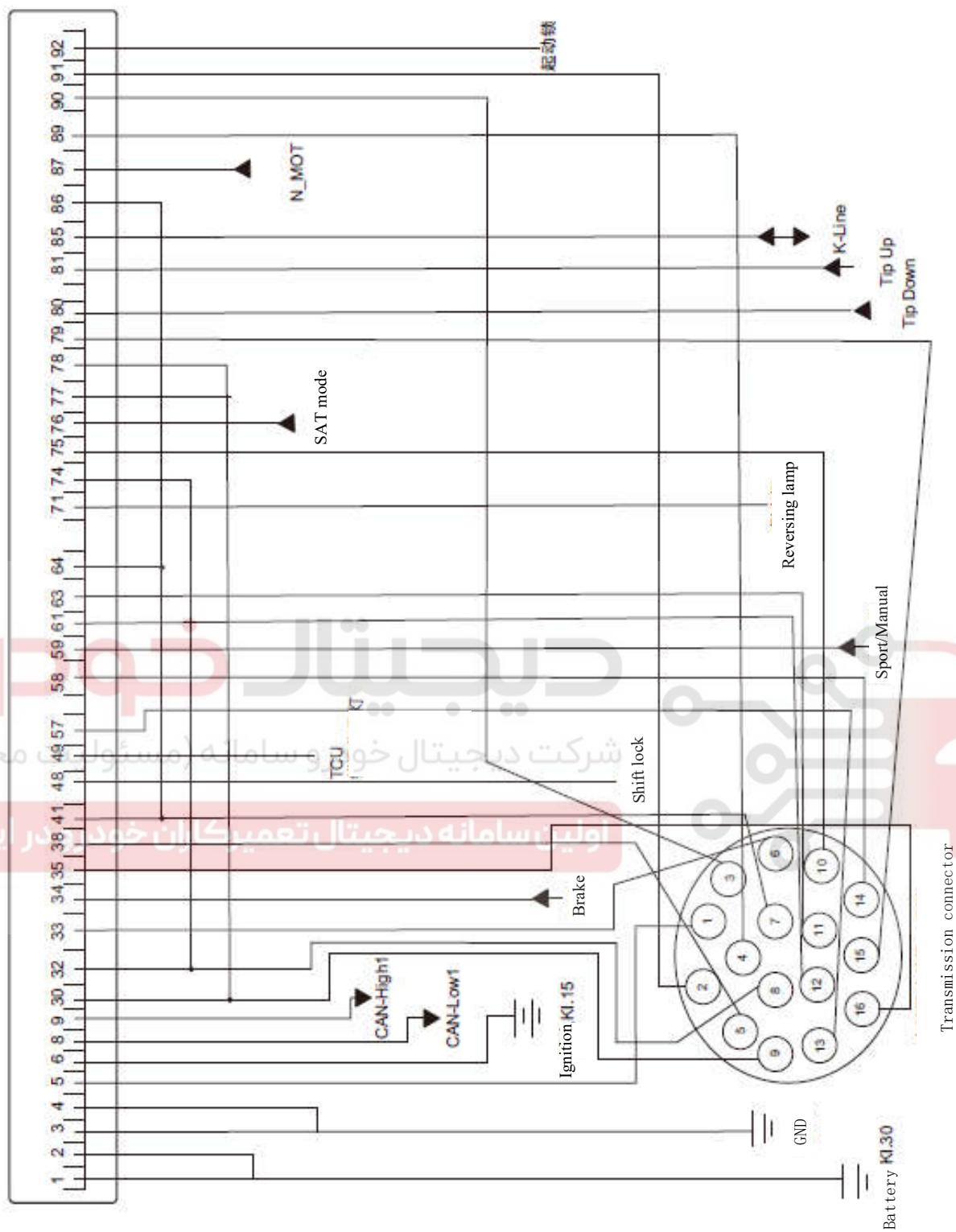

## CVT Transmission

## TCU pin assignment

VT2- signal	Pin
Normally closed power K1.30	1; 2
Ignition power K1.15	6
Ground K1.31	3; 4
VHSD1 (actuator power)	5
Speed and position sensor power (8.4V)	30; 77; 78
Pressure Sensor Power (5V)	32; 74
GND driving mode sensor	33
GND sensor grounded	41; 64; 86
Transmission oil temperature	38
N_Prim (driving bevel gear speed)	61
N_ab(driven bevel gear speed)	63
N_MOT (Engine speed signal)	87
DMS_A (Driving mode sensor signal)	57
DMS_B (Driving mode sensor signal)	58
DMS_C (Driving mode sensor signal)	79
DMS_D (Driving mode sensor signal)	35
Brake signal	34
Manual mode signal	59
Plus gear signal	81
Lower gear signal	80
P_S2 (driven bevel gear pressure)	75
Snow mode	76
Shift lock	48
K-Line	85
CAN- High speed	9
CAN- Low speed	8

CVT Transmission

VT2- signal	Pin
Starting lock	92
EDS1 driven bevel gear pressure regulator	91
EDS2 driven bevel gear pressure regulator	90
EDS3 driven bevel gear pressure regulator	89
Reversing Light Relay	71

TCU and gearbox pin corresponding figure

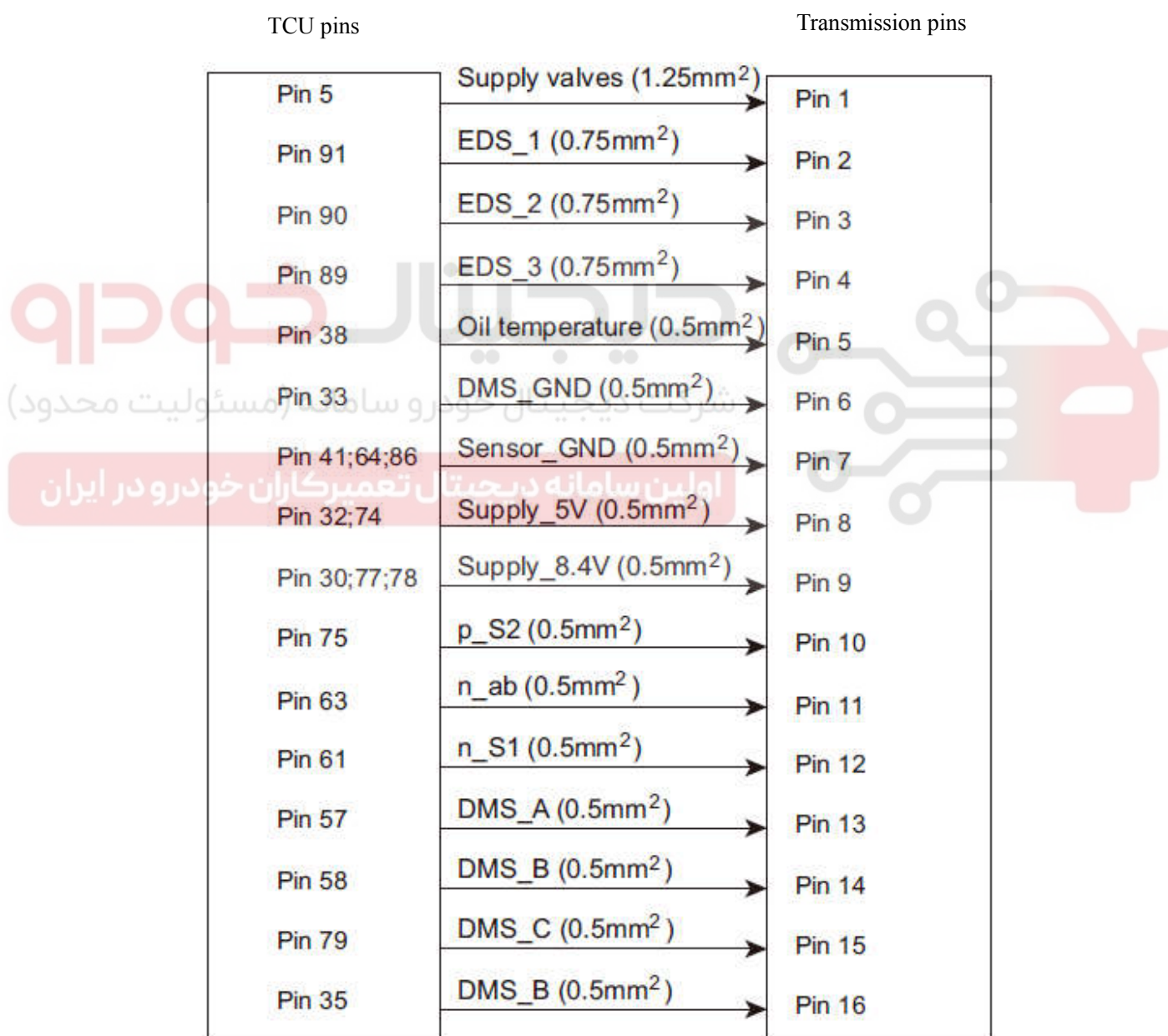

(II) Electronic Components Checklist

Driving mode sensor

Check the internal resistance of different pins, check whether the driving mode sensor is good.

## CVT Transmission

DMS\_GND = 6 pin  
 DMS\_A = 13 pin  
 DMS\_B = 14 pin  
 DMS\_C = 15 pin  
 DMS\_D = 16 pin  
 DMS\_Supply = 9 pin

Corresponding to the resistance value of each pin

	DMS_Supply	DMS_A	DMS_B	DMS_C	DMS_D
DMS_Supply	x	17.2 M Ω	17.2 M Ω	17.2 M Ω	17.2 M Ω
DMS_A	17.2 M Ω	x	9 K Ω	9 K Ω	9 K Ω
DMS_B	17.2 M Ω	9 K Ω	x	9 K Ω	9 K Ω
DMS_C	17.2 M Ω	9 K Ω	9 K Ω	x	9 K Ω
DMS_D	17.2 M Ω	9 K Ω	9 K Ω	9 K Ω	x
DMS_GND		4.5 K Ω	4.5 K Ω	4.5 K Ω	4.5 K Ω

### Temperature sensor

Measure the temperature sensor internal resistance.

Measure the resistance between 5th pin and 7th pin.

When the temperature is between 20 °C to 40 °C, the resistance should be 942 to 1121 Ω.

### Rotation speed sensor

This is a complex two-wire components, there is no simple way to measure whether it works within the following ranges or not.

·Measured the resistance between 9 pin and 11 pin is about 24.3 M Ω.

·Measured the resistance between 9 feet and 12feet is about 24.3 M Ω.

△Note: through this measure method can't guarantee the rotation speed is good.

### Oil pressure sensor

Measured the resistance between 7 pin and 10 pin is about 24.3 KΩ.

### Clutch pressure regulator

Measured the resistance between 1 pin and 4 pin is about 5.2 Ω.

### Driving bevel gear pressure regulator

Measured the resistance between 1 pin and 4 pin is about 5.2 Ω.

### Driven bevel gear pressure regulator

Measured the resistance between 1 pin and 4 pin is about 5.2 Ω.

TCU can't be measured

CVT Transmission

ΔNote: different precision measuring instruments will lead to a different measure resistance range.

(III) Transmission system schematic

TCU controller and gear shift controller power, ground, data cable.

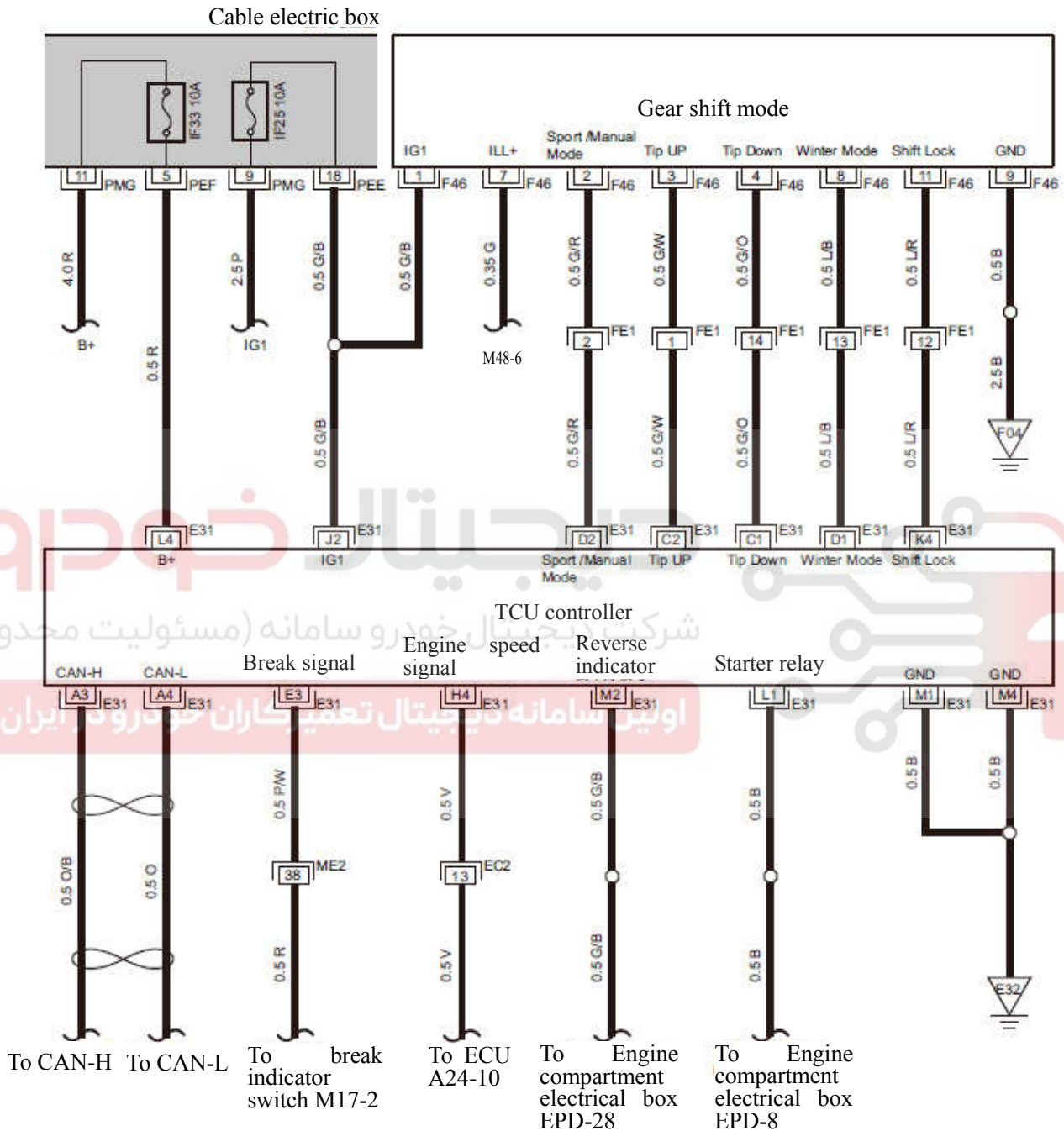

CVT Transmission

Transmission gear shift control module

